

ERSATZTEILLISTE | Spare parts list

Liste des pièces de rechange | Lista de repuestos

MU-PRO VARIO 220 - 320

AB SERIE | as of series | à partir de série | desde de la serie 2016

AUSGABE | edition | version | edición 03.2020

ARTIKELNUMMER | article number | número d'article | número de artículo MU-PRO_ET_16_2019-11

Übertragen Sie hier bitte die Daten Ihres Gerätes und des verwendeten Getriebes.

Enter the details for your implement and the gear box you are using here.

Veuillez inscrire ici les références de votre machine et celles du Système d'entraînement.

Introduzca aquí los datos de su equipo y la transmisión utilizada.



Beispiel Typenschild | Type plate example
Exemple de plaque signalétique | Ejemplo de una placa de características

Benennung Designation Désignation Designación	Eintrag Entry N° d'enregistrement Registro
Modell Model Modèle Modelo	MU-PRO VARIO 220 - 320 <input type="checkbox"/> 220 <input type="checkbox"/> 250 <input type="checkbox"/> 280 <input type="checkbox"/> 280 mittig <input type="checkbox"/> 300 <input type="checkbox"/> 320
Seriennummer Serial number N° de série Número de serie	
Baujahr Year of manufacture Année de construction Año de construcción	
Getriebetyp Gearbox type Type de Système d'entraînement Tipo de transmisión	
Anbaubock Headstock Attelage Soporte adosado	<input type="checkbox"/> fest fixed fixe fijo <input type="checkbox"/> verschiebbar movable déportable móvil
Händler Dealer Distributeur Concesionario	
Inbetriebnahme am Commissioning date Date de mise en service Fecha de puesta en servicio	

Bei bitte deutlich ankreuzen !

Where there are checkboxes , please check these clearly!

Veuillez cocher les cases lisiblement!

Por favor, marque con una cruz en la casilla .



Einleitung Introduction Introduction Introducción	4
Gerätebeschreibung Device description Description de l'a ppareil Description del dispositivo	5
Grundausführung Basic model Modèle de base Modelo básico 	
Gehäuse Housing Caisson Caja 	6
Kurzhäckselleiste Short chopping bar Lame hache-paille courte Listón de corte de paja corto 	14
Schiebebock Headstock Attelage Soporte adosado 	16
Antrieb & Getriebe Drive and gear box Transmission et Système d'entraînement Accionamiento e Cambio 	22
Übersetzung Getriebe Gear box translation Système d'entraînement multiplication Cambio la traducción 	28
Riemenspanner Einzelteile Belt tensioner parts Tendeur de courroie en pièces Tensor de correa de despiece 	30
Hammerrotor Hammer rotor Marteaux rotor Rotor de martillo 	32
Stützwalze Support roller Rouleau d'appui Cilindro de apoyo 	36
Getriebe Gear box Système d'entraînement Cambio 	38
Sonderzubehör Optional accessory Accessoires optionnels Componente especial 	
Gelenkwelle - GE2501 Cardan shaft - GE2501 Arbre de transmissio - GE2501 Árbol de transmisión - GE2501 	42
Schäkelrotor Shackle rotor Manille rotor Grillete rotor 	44
Werkzeugvariante Y- Schlegel Variante of Y-tool Version d´outils couteaux Y Variante de Y-martillo 	48
2.Kurzhäckselleiste 2.Short chopping bar 2.Lame hache-paille courte 2.Listón de corte de paja corto 	50
Schneidschiene Cutting bar Contre-lame réglable Carril de corte 	52
Verschleißeinlage Wear insert Blindage Junta de desgaste 	54
Abstreiferschneide Cleaner cutting edge Lame de racloir Cuchilla del rascador 	56
Betriebsstundenzähler Operating hours counter Compteur horaire Contado de horas de servicio 	58
Beleuchtungsträger fest Lighting equipment fixed Support d`éclairage fixe Soporte de alumbrado fijo 	60
Beleuchtungsträger Lighting equipment Support d`éclairage Soporte de alumbrado 	62
Warntafel mit Beleuchtungseinrichtung Warning sign with lighting equipment Panneau de signalisation avec systém d`éclairage Panel de aviso con dispositivo de iluminación 	64
Federentlastungspaket Shock-absorbing spring assembly Kit de délestage mécanique Conjunto de muelle de compensación 	66
Hydraulische Druckentlastung MU-SOFA Hydraulic pressure relief MU-SOFA Délestage hydraulique MU-SOFA Descarga de presión hidráulica MU-SOFA 	68
Kontakte Contacts Contacts Contactos 	
National Nactional Nationaux Nacionales 	72
International Internactional Internationaux Internacionales 	74

SEHR GEEHRTER KUNDE,

auf den folgenden Seiten finden Sie eine vollständige Übersicht aller Bauteile Ihres Müthing Mulchgerätes MU-PRO VARIO 220 - 320. Anhand dieser Unterlage bitten wir Sie benötigte Ersatzteile genau zu identifizieren und mit den nachfolgenden Angaben zu bestellen. Benötigen Sie Hilfe oder weitere Informationen kontaktieren Sie uns.

Vielen Dank - Ihr Müthing-Team

CHER CLIENT,

Vous trouverez sur les pages suivantes une description complète des composants de votre broyeur Müthing MU-PRO VARIO 220 - 320. Nous vous invitons à identifier exactement les pièces de rechange requises à l'appui de ce document et de les commander en indiquant le n° de référence de pièces de rechange. N'hésitez pas à nous contacter si vous avez besoin d'aide ou d'informations complémentaires.

Merci beaucoup - Votre équipe Müthing

DEAR CUSTOMER,

The following pages offer a complete overview of the components in your Müthing MU-PRO VARIO 220 - 320 mulcher. We are providing you with this document so that you can identify exactly the spare parts you require and order them using the spare part numbers listed. Should you need any assistance or further information, please contact us.

Kind regards - Your Müthing team

ESTIMADO CLIENTE,

En las siguientes páginas ponemos a su disposición una relación completa de los componentes de su trituradora MU-PRO VARIO 220 - 320 de Müthing. Le rogamos que con ayuda de este listado identifique las piezas de repuesto necesarias y las encargue con su correspondiente número de repuesto. No dude en ponerse en contacto con nosotros para solicitar ayuda o información ampliada.

Muchas gracias - Su equipo Müthing



Beachten Sie immer die Sicherheitshinweise der Betriebsanleitung !

Always follow the safety instructions in the operating manual.

Veuillez toujours tenir compte des consignes de sécurité figurant dans le manuel d'utilisation !

Observe siempre las indicaciones de seguridad de las instrucciones de servicio !

DIE HAUPTBAUGRUPPEN SIND:

1. Dreipunktanbaubock Kat.2 + Kat.3 verschiebbar
2. Mulchergehäuse mit Schutzlamellen, hinterem Gummischutz und Gleitkufen
3. Rotor mit Lagerung, Werkzeugen und Werkzeughaltern
4. Stützwalze (Stützräder) mit Lagerung
5. Keilriemenantrieb mit Keilriemenschutzhaube
6. Getriebe
7. Gelenkwelle (Explosionszeichnung)
8. Sonderzubehör

THE MAIN COMPONENTS ARE:

1. Three-point headstock Kat.2+ Kat.3 movable
2. Mulcher housing with protective strips, rear rubber protector and skids
3. Rotor with mount, tools and tool holders
4. Support roller (support wheels) with mount
5. V-belt drive with V-belt guard
6. Gear box
7. PTO shaft (exploded view)
8. Optional accessories



LES GROUPES PRINCIPAUX SONT:

1. Attelage trois points Kat.2 + Kat.3 déport latéral possible
2. Carter du broyeur avec lamelles de protection, protection en caoutchouc à l'arrière et patins de glissement
3. Rotor équilibré avec outils et supports d'outils
4. Rouleau d'appui (roue palpeuse) avec suspension
5. Transmission par courroie trapézoïdale avec capot de protection
6. Système d'entraînement
7. Arbre de transmission (vue éclatée)
8. Accessoires spécifiques

LOS GRUPOS CONSTRUCTIVOS PRINCIPALES SON:

1. Enganche de tres puntos Kat.2 + Kat.3 desplazable
2. Carcasa de la trituradora con placas de protección, protección trasera de goma y patines
3. Rotor con cojinete, herramientas y portaherramientas
4. Cilindro de apoyo (ruedas de apoyo) con cojinete
5. Accionamiento por correa trapezoidal con cubierta protectora de la correa
6. Cambio
7. Árbol de transmisión (plano explosionado)
8. Accesorio especial

| Hauptbaugruppe Schlegelmulcher Baureihe MU-PRO VARIO 220 - 320
| Main assembly of the MU-PRO VARIO 220 - 320 flail mulcher
| Groupe principal broyeur à marteaux série MU-PRO VARIO 220 - 320
| Grupo constructivo desbrozadora serie MU-PRO VARIO 220 - 320

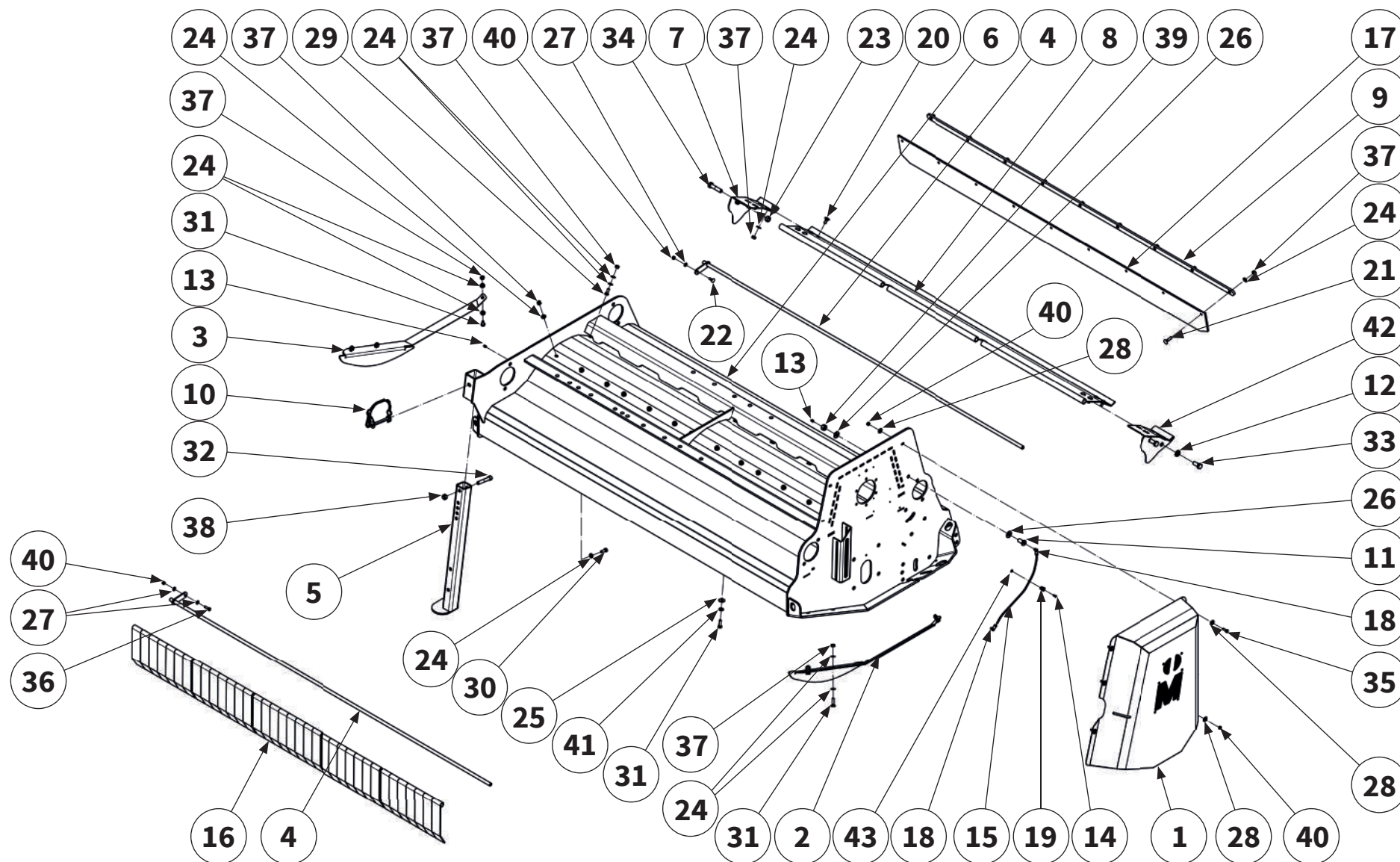

Pos.-Nr. No. Numéro Número	Ersatzteilnummer Manufacturer part number Numéro d'article du fabricant Número de pieza del fabricante						DE Bezeichnung	EN Designation	FR Désignation	ES Designación
	Anzahl quantity quantité número									
	MU-Pro 220	MU-Pro 250	MU-Pro 280	MU-Pro 280 mittig	MU-Pro 300	MU-Pro 320				
1	MU0205497						Schutz- abdeckung	protective cover	Recouvrement de protection	Cubierta protectora
2	MU0608406						Verschleißkufe links	wear runner	Patin d'usure	Cuchilla de desgaste
3	MU0608408						Verschleißkufe rechts	wear runner	Patin d'usure	Cuchilla de desgaste
4	MU0808039 2	MU0807487 2	MU0806458 2		MU0807110 2	MU0807491 2	Pendelwelle	swing shaft	Arbre oscillant	Eje del péndulo
5	MUM01059						Stütze	pillar	Support	Apoyo
6	MU0808022 1	MU0807040 1	MU0807042 1		MU0807044 1	MU0807046 1	Gehäuse	Housing	Caisson	Caja
7	MU0807048						Halteblech	support plate	Tôle de support	Chapa de retención
8	MU0808037 1	MU0807050 1	MU0807052 1		MU0807054 1	MU0807056 1	Gutleitklappe	material guiding flap	Clapet conducteur	Tapa guía para material
9	MU0912061 1	MU0912057 1	MU0910503 1		MU0911749 1	MU0913118 1	Halteeisen	support plate	Tôle de support	Chapa de retención
10	MUM03001						Bolzen mit Kette	pin with chain	Axe avec Chaîne	Perno con Cadena
11	MU1200454						Schraube	bolt	Vis	Tornillo
12	MUNSKL16						Scheibe	washer	Disque	Arandela
13	DIN71412-H1-M08x1						Schmiernippel	lubricating nipple	Nipple de graissage	Engrasador



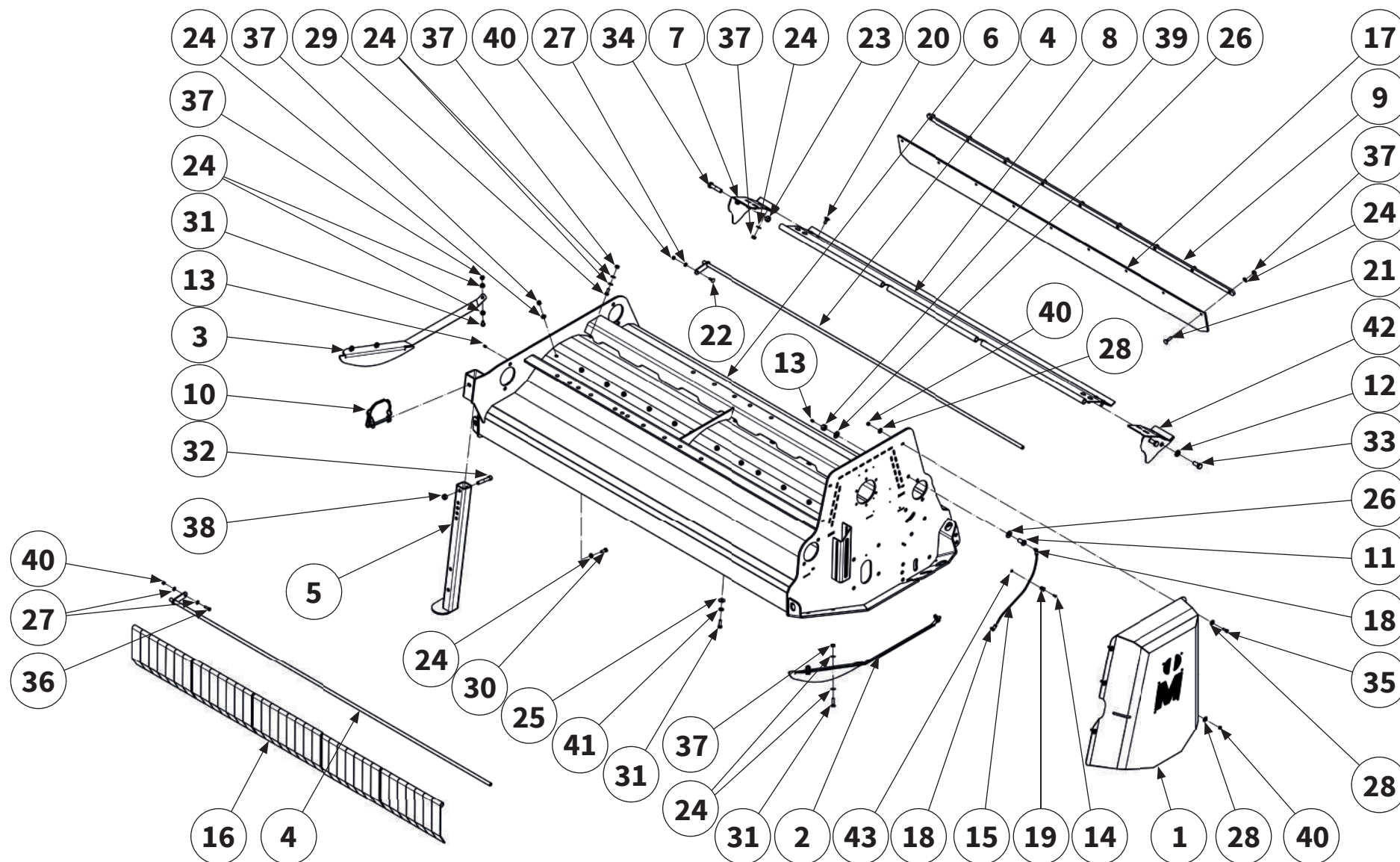

Pos.-Nr. No. Número	Ersatzteilnummer Manufacturer part number Numéro d'article du fabricant Número de pieza del fabricante						DE Bezeichnung	EN Designation	FR Désignation	ES Designación
	Anzahl quantity quantité número									
	MU-Pro 220	MU-Pro 250	MU-Pro 280	MU-Pro mittig	MU-Pro 300	MU-Pro 320				
14	MUMG0004						Blindniete	pop rivet	Rivet aveugle	Remache ciego
	1	1	1	1	1	1				
15	MULI0005						Schmierleitung	lubrication line	Conduite de graissage	Tubería de engrase
	0,5m	0,5m	0,5m	0,5m	0,5m	0,5m				
16	MAX00098-1						Pendelklappen	flap with swing protection	Volvet de protection	Tapa protecto del púendolo
	36	41	46	46	49	53				
17	PO.300-8						Schutzgummi	guard	Protection	Protección
	2,25m	2,55m	2,85m	2,85m	3,05m	3,25m				
18	MULI0006						Winkelverbinder	elbow connector	Connecteur d'angle	Conector en ángulo
	2	2	2	2	2	2				
19	MUMG0005						Schelle mit Gummi	clamp	Collier	Abrazadera
	1	1	1	1	1	1				
20	00000903						Schraube	bolt	Vis	Tornillo
	4	4	4	4	4	4				
21	MU980250						Schraube	bolt	Vis	Tornillo
	9	10	11	11	13	13				
22	MU0099988						Schraube	bolt	Vis	Tornillo
	1	1	1	1	1	1				
23	MU0099964						Mutter	nut	Écrou	Tuerca
	2	2	2	2	2	2				
24	MU980202						Scheibe	washer	Disque	Arandela
	73	82	85	85	89	99				
25	MU0099950						Scheibe	washer	Disque	Arandela
	11	13	14	14	15	16				
26	MU980402						Scheibe	washer	Disque	Arandela
	2	2	2	2	2	2				



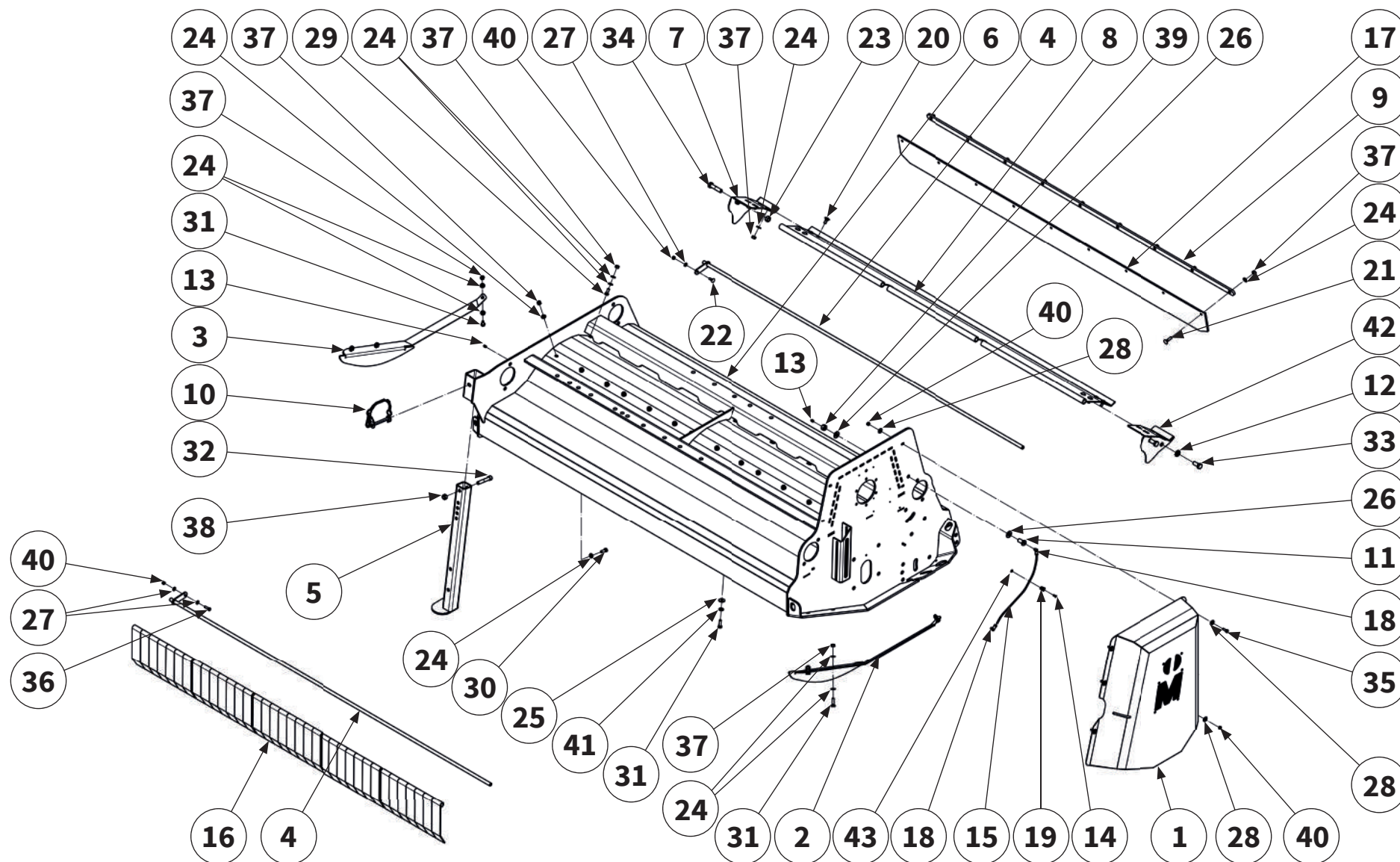

Pos.-Nr. No. Número	Ersatzteilnummer Manufacturer part number Numéro d'article du fabricant Número de pieza del fabricante						DE Bezeichnung	EN Designation	FR Désignation	ES Designación
	Anzahl quantity quantité número									
	MU-Pro 220	MU-Pro 250	MU-Pro 280	MU-Pro 280 mittig	MU-Pro 300	MU-Pro 320				
27	MU0099999						Scheibe	washer	Disque	Arandela
	3	3	3	3	3	3				
28	MU0099951						Scheibe	washer	Disque	Arandela
	11	11	11	11	11	11				
29	MU980208						Schraube	bolt	Vis	Tornillo
	9	11	11	11	12	13				
30	MU980205						Schraube	bolt	Vis	Tornillo
	13	15	16	16	18	20				
31	MU980222						Schraube	bolt	Vis	Tornillo
	17	19	20	20	21	22				
32	MU980512						Schraube	bolt	Vis	Tornillo
	1	1	1	1	1	1				
33	MU980406						Schraube	bolt	Vis	Tornillo
	2	2	2	2	2	2				
34	MU980438						Schraube	bolt	Vis	Tornillo
	2	2	2	2	2	2				
35	MU980109						Schraube	bolt	Vis	Tornillo
	5	5	5	5	5	5				
36	MU0099908						Schraube	bolt	Vis	Tornillo
	1	1	1	1	1	1				
37	MU0099960						Mutter	nut	Écrou	Tuerca
	45	50	52	52	53	60				
38	MU980501						Mutter	nut	Écrou	Tuerca
	1	1	1	1	1	1				
39	MU980401						Mutter	nut	Écrou	Tuerca
	1	1	1	1	1	1				
40	MU0099961						Mutter	nut	Écrou	Tuerca
	8	8	8	8	8	8				

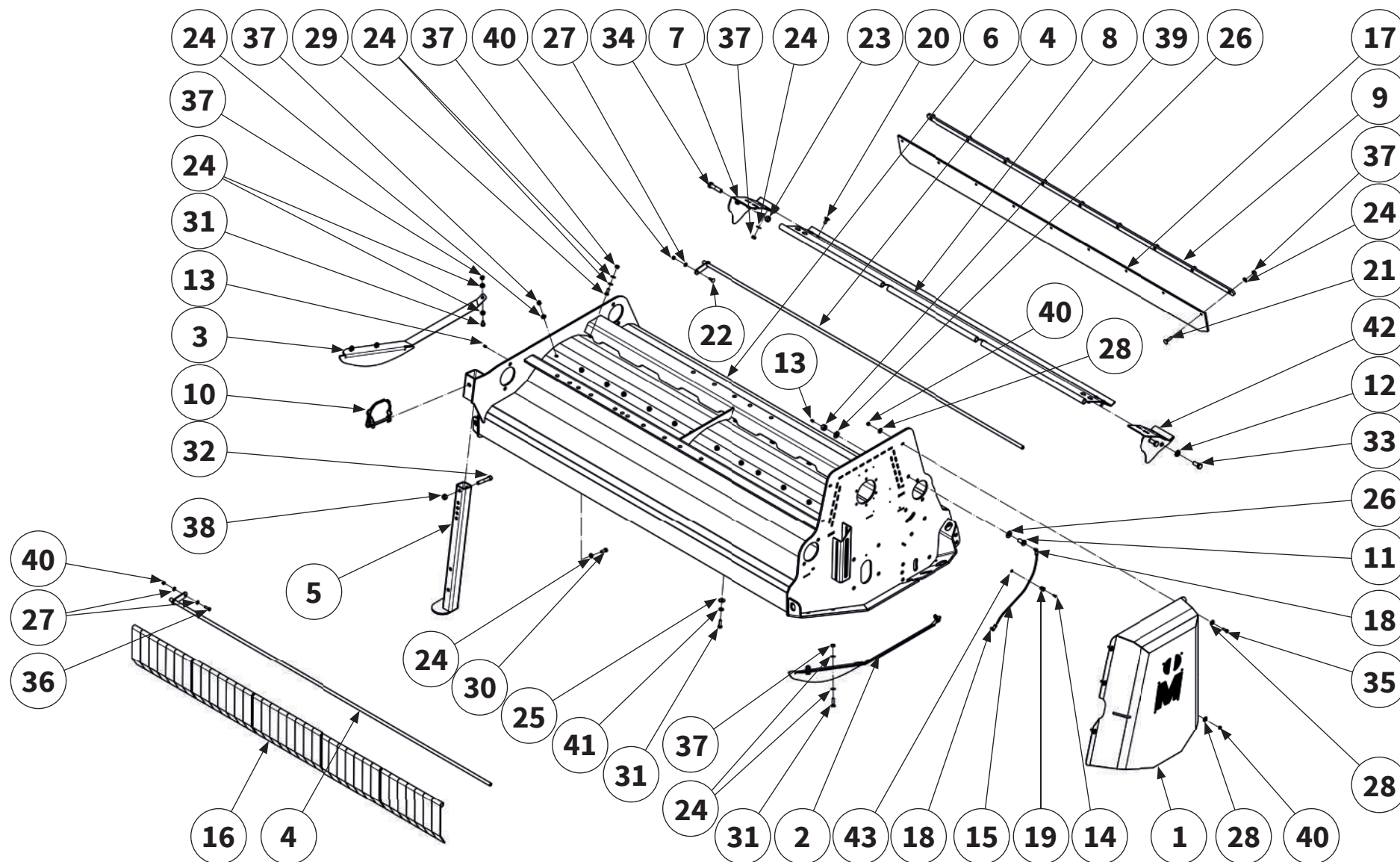

Pos.-Nr. No. Numéro Número	Ersatzteilnummer Manufacturer part number Numéro d'article du fabricant Número de pieza del fabricante						DE Bezeichnung	EN Designation	FR Désignation	ES Designación
	Anzahl quantity quantité número									
	MU-Pro 220	MU-Pro 250	MU-Pro 280	MU-Pro 280 mittig	MU-Pro 300	MU-Pro 320				
41	MUNSKL10						Scheibe	washer	Disque	Arandela
	11	13	14	14	15	16				
42	MU0807048						Einstellblech	support plate	Tôle de support	Chapa de retención
	1	1	1	1	1	1				
43	MU980006						Scheibe	washer	Disque	Arandela
	1	1	1	1	1	1				



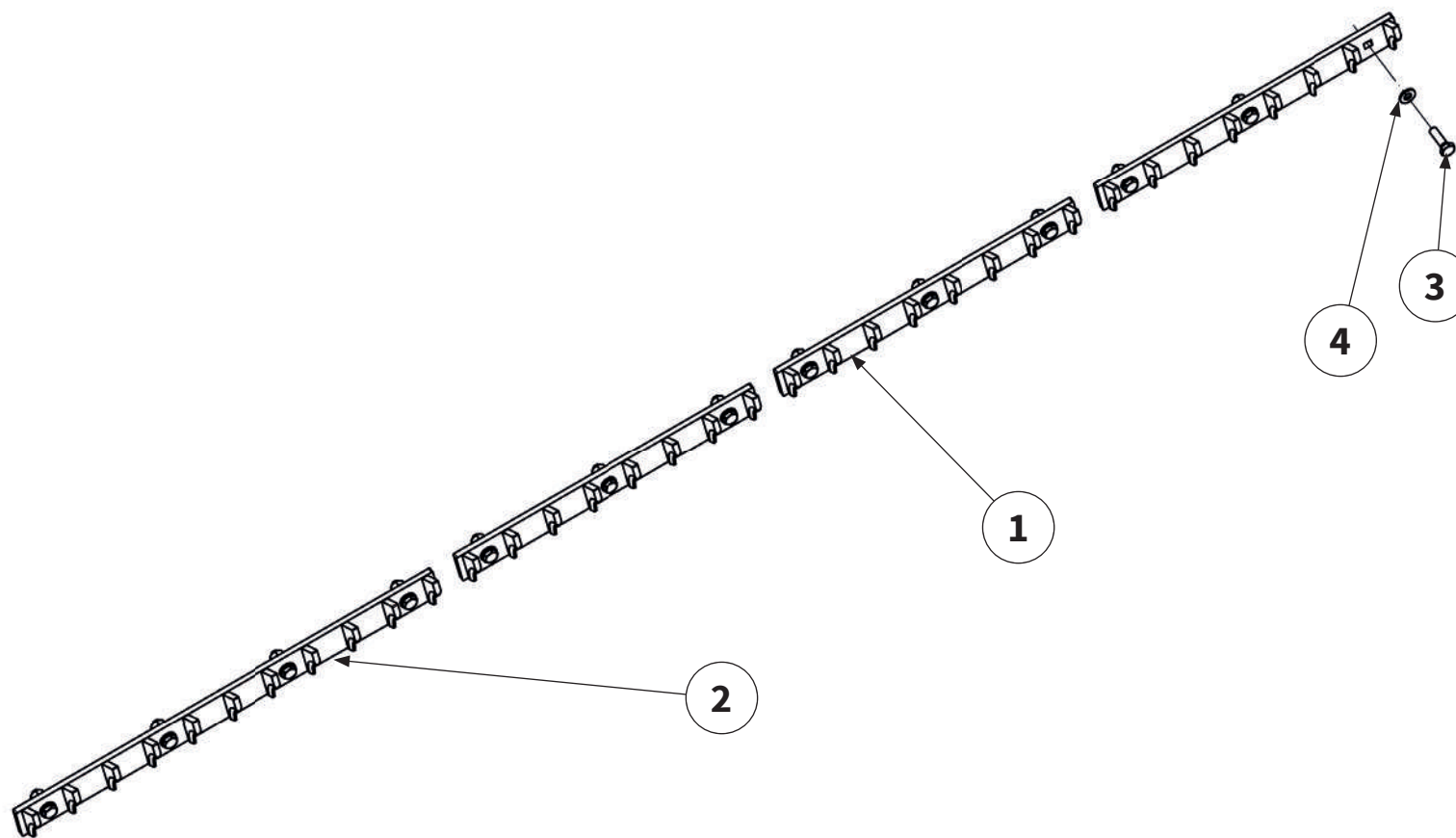

Pos.-Nr. No. Número	Ersatzteilnummer Manufacturer part number Numéro d'article du fabricant Número de pieza del fabricante						DE Bezeichnung	EN Designation	FR Désignation	ES Designación
	Anzahl quantity quantité número									
	MU-Pro 220	MU-Pro 250	MU-Pro 280	MU-Pro 280 mittig	MU-Pro 300	MU-Pro 320				
Maschine mit Hammerrotor Machine with Hammer rotor Machine avec Rotor à marteaux Máquina con Rotor de martillo 										
1	3	5	-	-	6	4	Gegen- schneide 400	short-chopping bar	Lame hache- paille courte	Listón de corte de paja corto
2	1	-	4	4	-	2	Gegen- schneide 600	short-chopping bar	Lame hache- paille courte	Listón de corte de paja corto
3	13	15	16	16	18	20	Schraube	bolt	Vis	Tornillo
4	13	15	16	16	18	20	Scheibe	washer	Disque	Arandela
Maschine mit Schäkelrotor Machine with Shackle rotor Machine avec Rotor à manilles Máquina con Rotor de grilletes 										
1	3	5	-	-	6	4	Gegen- schneide 400	short-chopping bar	Lame hache- paille courte	Listón de corte de paja corto
2	1	-	4	4	-	2	Gegen- schneide 600	short-chopping bar	Lame hache- paille courte	Listón de corte de paja corto
3	13	15	16	16	18	20	Schraube	bolt	Vis	Tornillo
4	13	15	16	16	18	20	Scheibe	washer	Disque	Arandela



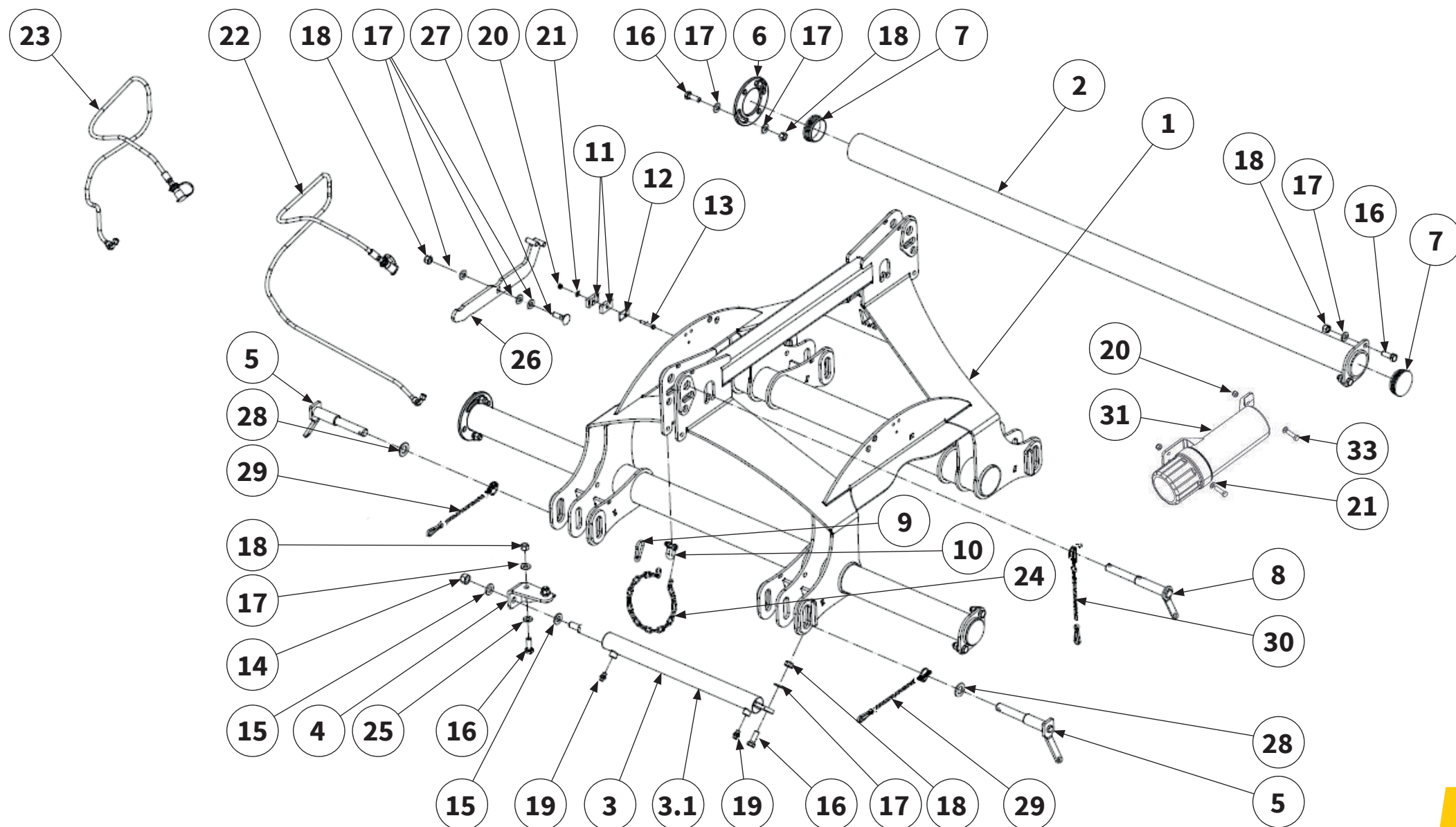

Pos.-Nr. No. Número	Ersatzteilnummer Manufacturer part number Numéro d'article du fabricant Número de pieza del fabricante						DE Bezeichnung	EN Designation	FR Désignation	ES Designación
	Anzahl quantity quantité número									
	MU-Pro 220	MU-Pro 250	MU-Pro 280	MU-Pro 280 mittig	MU-Pro 300	MU-Pro 320				
1	MU0807022						Dreipunktbock	3-point trestle	Support d'attelage trois point	Soporte de tres apoyos
2	MU0808041	MUM01027					Schieberohr	circular pipe	Tuyau rond	Tube redondo
3	MUHZ003						Zylinder kpl.	hydraulic cylinder	Vérin hydraulique	Cilindro hidráulico
3.1	MUDZ0004						Dichtsatz Zylinder	Seal Kit Cylinder	Kit d'étanchéité	Juego de estanqueización
4	MU0804851						Zylinderhalter	cylinder bracket	Porte-cylindre	Porta cilindro
5	MU1202733						Unterlenkerbolzen	pin	Axe	Perno
6	MUM01033						Scheibe	washer	Disque	Arandela
7	MUMG0023						Lamellenstopfen	sealing plug	Bouchon de fermeture	Tapón de cierre
8	MU1202764						Oberlenkerbolzen	pin	Axe	Perno
9	MUMG0007						Karabinerhaken	securing hook	Crochet de sécurité	Gancho de retención
10	MUMG0015						Schäkel	shackle	Manille	Grillete
11	MUMG0016						Rohrschelle	clamp body	Corps de collier	Corps de collier
12	MUMG0014						Deckplatte	cover plate	Plaque de recouvrement	Placa de revestimiento

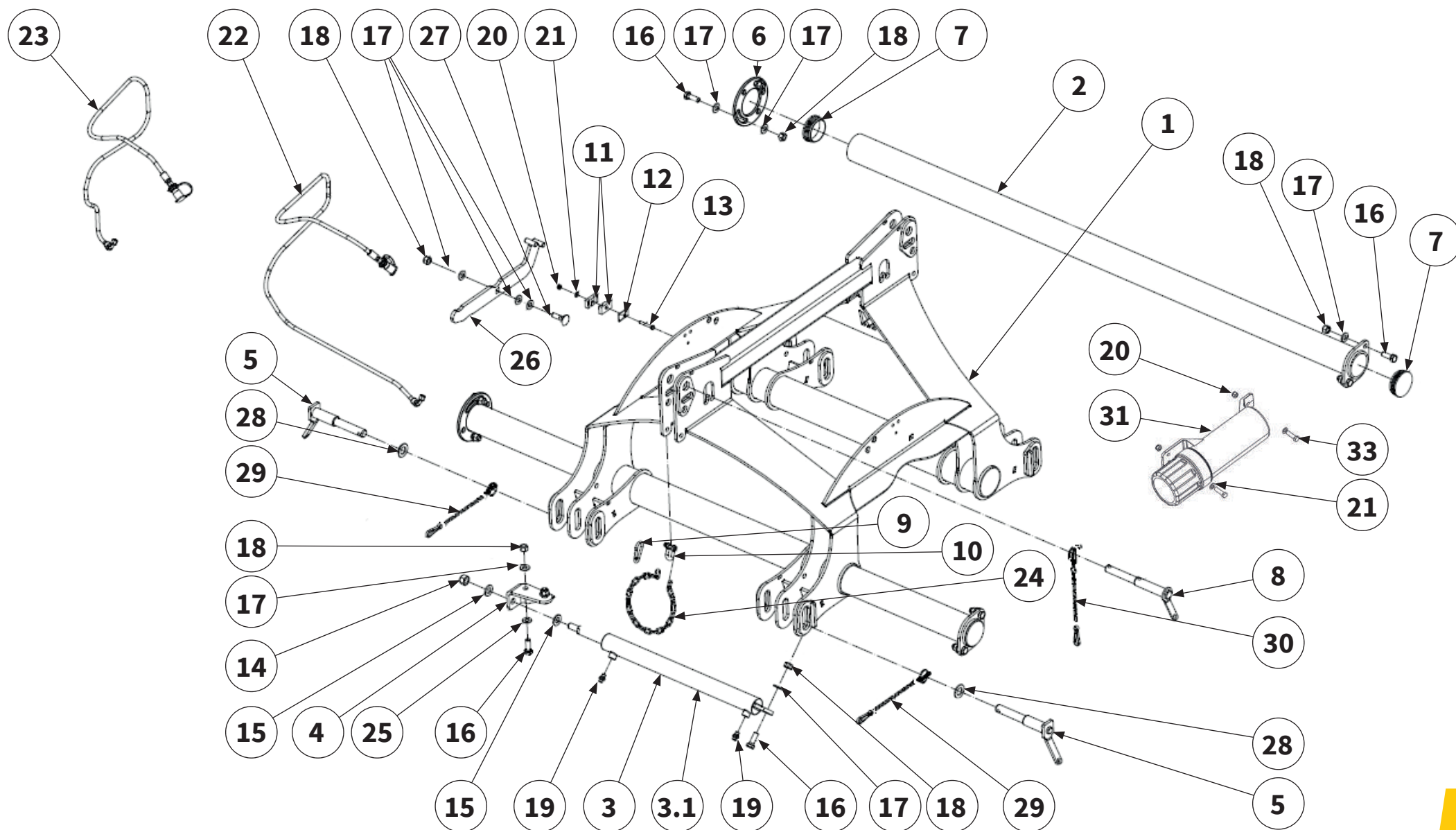

Pos.-Nr. No. Numéro Número	Ersatzteilnummer Manufacturer part number Numéro d'article du fabricant Número de pieza del fabricante						DE Bezeichnung	EN Designation	FR Désignation	ES Designación
	Anzahl quantity quantité número									
	MU-Pro 220	MU-Pro 250	MU-Pro 280	MU-Pro 280 mittig	MU-Pro 300	MU-Pro 320				
13	MU980118						Schraube	bolt	Vis	Tornillo
	1	1	1	1	1	1				
14	MU980504						Mutter	nut	Écrou	Tuerca
	1	1	1	1	1	1				
15	MU980505						Scheibe	washer	Disque	Arandela
	2	2	2	2	2	2				
16	MU980407						Schraube	bolt	Vis	Tornillo
	11	11	11	11	11	11				
17	MU980402						Scheibe	washer	Disque	Arandela
	18	18	18	18	18	18				
18	MU980401						Mutter	nut	Écrou	Tuerca
	11	11	11	11	11	11				
19	00008101						Verschraubung	Screwed connection	Raccord à vis	Atornillamiento
	2	2	2	2	2	2				
20	MU0099961						Mutter	nut	Écrou	Tuerca
	3	3	3	3	3	3				
21	MU0099999						Scheibe	washer	Disque	Arandela
	3	3	3	3	3	3				
22	MU980719						Hydraulikschlauch	hydraulic hose	Tuyau hydraulique	Tubo flexible hidráulico
	1	1	1	1	1	1				
23	MUMG0025						Hydraulikschlauch	hydraulic hose	Tuyau hydraulique	Tubo flexible hidráulico
	1	1	1	1	1	1				
24	MUMG0011						Kette	chain	Chaîne	Cadena
	1	1	1	1	1	1				
25	MUNSKL16						Scheibe	washer	Disque	Arandela
	2	2	2	2	2	2				



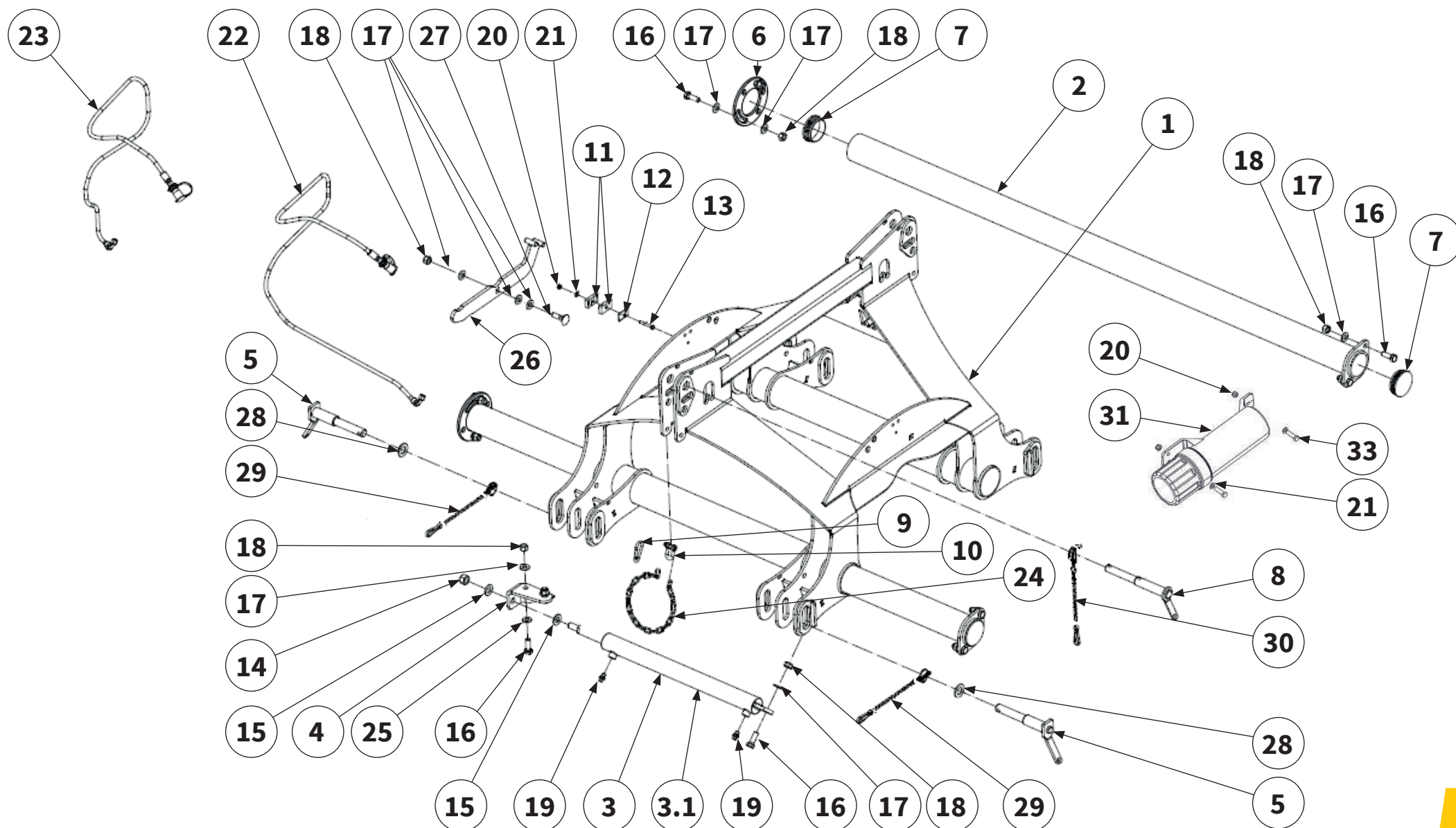

Pos.-Nr. No. Número	Ersatzteilnummer Manufacturer part number Numéro d'article du fabricant Número de pieza del fabricante						DE Bezeichnung	EN Designation	FR Désignation	ES Designación
	Anzahl quantity quantité número									
	MU-Pro 220	MU-Pro 250	MU-Pro 280	MU-Pro 280 mittig	MU-Pro 300	MU-Pro 320				
26	MU0807019						Schwenkhebel	Lever	Levier	Palanca
	1	1	1	1	1	1				
27	MU980428						Schraube	bolt	Vis	Tornillo
	1	1	1	1	1	1				
28	MU980507						Scheibe	washer	Disque	Arandela
	2	2	2	2	2	2				
29	MU2500106						Simplexhaken mit Kette	securing hook with chain	Crochet de sécurité avec Chaîne	Gancho de retención con Cadena
	2	2	2	2	2	2				
30	MU2500107						Simplexhaken mit Kette	securing hook with chain	Crochet de sécurité avec Chaîne	Gancho de retención con Cadena
	1	1	1	1	1	1				
31	00034497						Dokumenten- rolle	document roll	Document rouleau	Rollo de docu- mento
	1	1	1	1	1	1				
32	MU0099908						Schraube	bolt	Vis	Tornillo
	2	2	2	2	2	2				

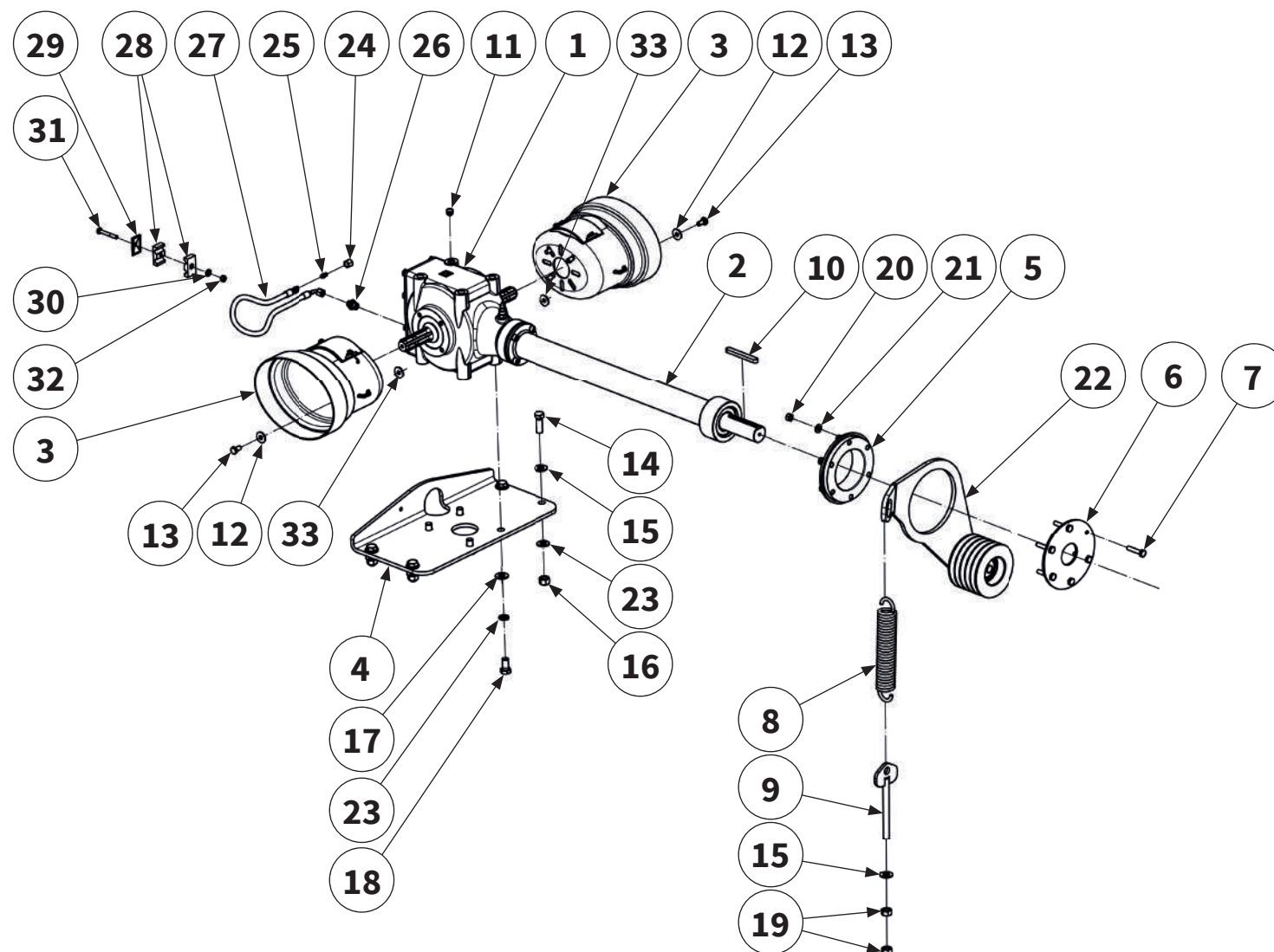

Eine detaillierte Explosionskizze des Getriebes finden Sie auf den folgenden Seiten.

A detailed exploded view of the gear box can be found on the following pages.

Vous trouverez un schéma éclaté détaillé du Système d'entraînement sur les pages suivantes.

En las siguientes páginas también se incluye un diagrama de vista explotada de la transmisión.



Pos.-Nr. No. Numéro Número	Ersatzteilnummer Manufacturer part number Numéro d'article du fabricant Número de pieza del fabricante						DE Bezeichnung	EN Designation	FR Désignation	ES Designación
	Anzahl quantity quantité número									
	MU-Pro 220	MU-Pro 250	MU-Pro 280	MU-Pro 280 mittig	MU-Pro 300	MU-Pro 320				
1	S2081						Getriebe	gear box	Système d'entraînement	Cambio
	1	1	1	1	1	1				
2	S2081 990			S2081 1400		S2081 1550	Getriebe- verlängerung	shaft extension	Arbre de rollonge	Prolongación
	1	1	1	1	1	1				
3	MU980814						Schutztopf	protective pot	Protevtive Pot	Tapa de protección
	2	2	2	2	2	2				
4	MU0605609						Getriebe- konsole	transmission console	Console de transmission	Consola del cambio
	1	1	1	1	1	1				
5	MUM00680						Buchse	bushing	Manchon	Cojinete
	1	1	1	1	1	1				
6	MUM00689						Scheibe	washer	Disque	Arandela
	1	1	1	1	1	1				
7	MU980219						Schraube	bolt	Vis	Tornillo
	6	6	6	6	6	6				
8	MU980912						Zugfeder	tension spring	Ressort de traction	Resorte de tracción
	1	1	1	1	1	1				
9	MAX00062						Zugstange	tie rod	Barre de traction	Barra de tracción
	1	1	1	1	1	1				
10	MU981810						Passfeder	parallel key	Clavette	Chaveta de ajuste
	1	1	1	1	1	1				
11	MUMG0018						Lamellen- stopfen	sealing plug	Bouchon de fermeture	Tapón de cierre
	4	4	4	4	4	4				



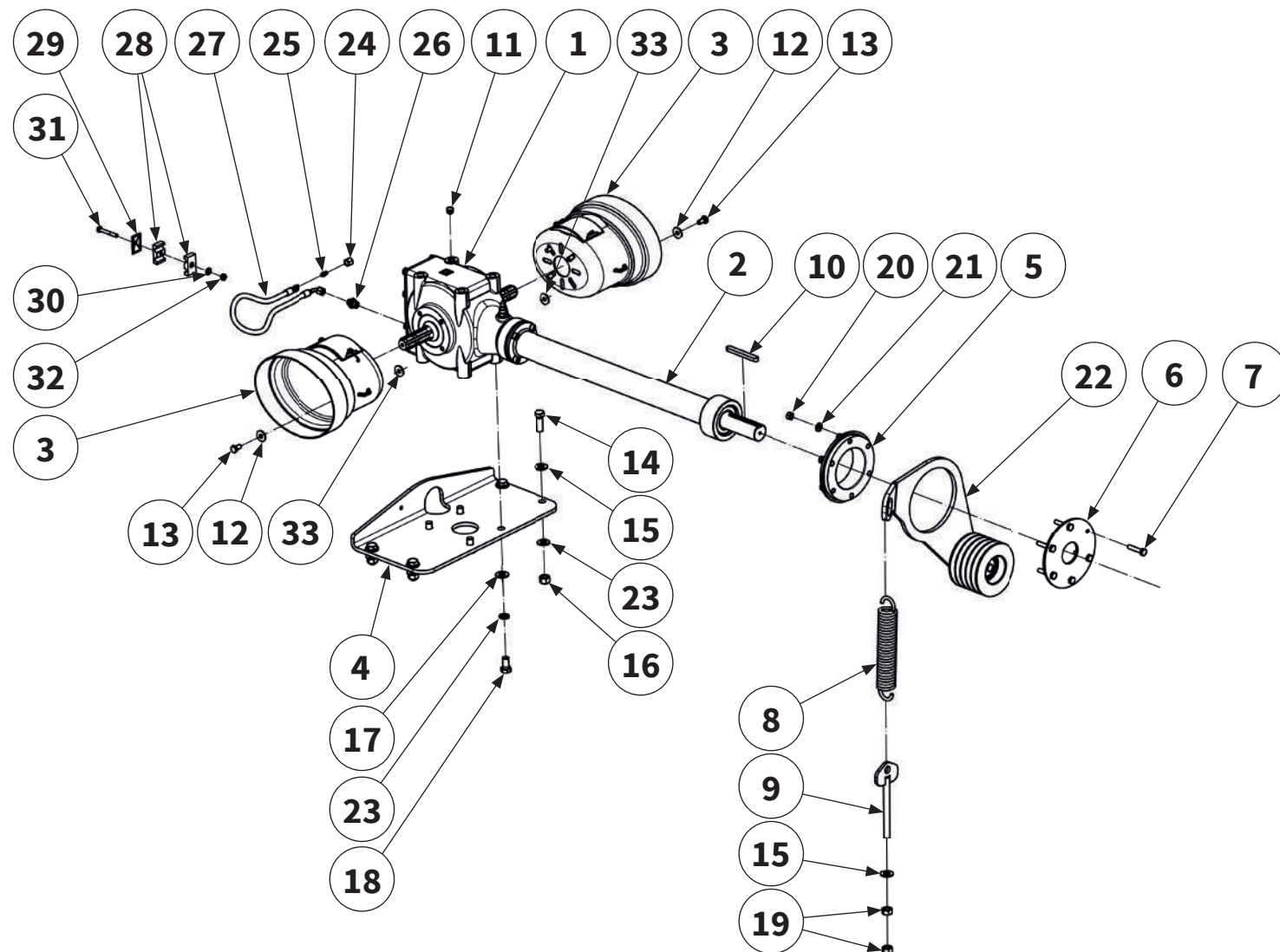

Eine detaillierte Explosionskizze des Getriebes finden Sie auf den folgenden Seiten.

A detailed exploded view of the gear box can be found on the following pages.

Vous trouverez un schéma éclaté détaillé du Système d'entraînement sur les pages suivantes.

En las siguientes páginas también se incluye un diagrama de vista explotada de la transmisión.



Pos.-Nr. No. Numéro Número	Ersatzteilnummer Manufacturer part number Numéro d'article du fabricant Número de pieza del fabricante						DE Bezeichnung	EN Designation	FR Désignation	ES Designación
	Anzahl quantity quantité número									
	MU-Pro 220	MU-Pro 250	MU-Pro 280	MU-Pro 280 mittig	MU-Pro 300	MU-Pro 320				
12	00019373						Scheibe	washer	Disque	Arandela
	8	8	8	8	8	8				
13	MU980205						Schraube	bolt	Vis	Tornillo
	8	8	8	8	8	8				
14	MU980407						Schraube	bolt	Vis	Tornillo
	4	4	4	4	4	4				
15	MU980402						Scheibe	washer	Disque	Arandela
	5	5	5	5	5	5				
16	MU980401						Mutter	nut	Écrou	Tuerca
	4	4	4	4	4	4				
17	00030482						Scheibe	washer	Disque	Arandela
	4	4	4	4	4	4				
18	MU980432						Schraube	bolt	Vis	Tornillo
	4	4	4	4	4	4				
19	MU980400						Mutter	nut	Écrou	Tuerca
	2	2	2	2	2	2				
20	MU980201						Mutter	nut	Écrou	Tuerca
	6	6	6	6	6	6				
21	MU980202						Scheibe	washer	Disque	Arandela
	6	6	6	6	6	6				
22	MU0200019						Riemen- spanner kpl.	belt tensioner	Tendeur de courroie	Tensor de correa
	1	1	1	1	1	1				
23	MUNSKL16						Scheibe	washer	Disque	Arandela
	8	8	8	8	8	8				
24	M 08-L						Mutter	nut	Écrou	Tuerca
	1	1	1	1	1	1				



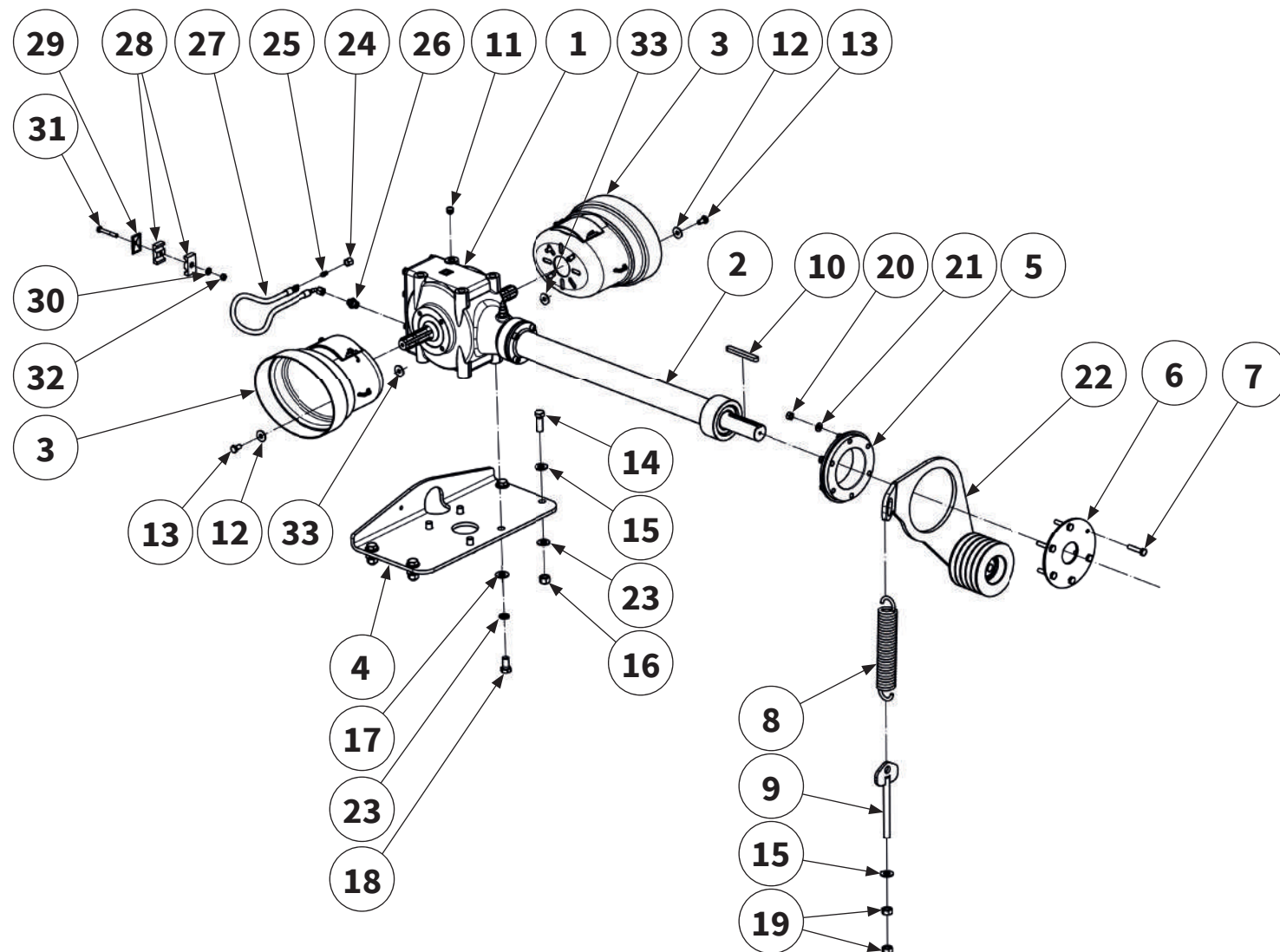

Eine detaillierte Explosionskizze des Getriebes finden Sie auf den folgenden Seiten.

A detailed exploded view of the gear box can be found on the following pages.

Vous trouverez un schéma éclaté détaillé du Système d'entraînement sur les pages suivantes.

En las siguientes páginas también se incluye un diagrama de vista explotada de la transmisión.



Pos.-Nr. No. Numéro Número	Ersatzteilnummer manufacturer Part number Numéro d'article du fabricant Número de pieza del fabricante						DE Bezeichnung	EN Designation	FR Désignation	ES Designación
	Anzahl quantity quantité número									
	MU-Pro 220	MU-Pro 250	MU-Pro 280	MU-Pro 280 mittig	MU-Pro 300	MU-Pro 320				
25	VKA 08						Verschluss-kegel	sealing plug	Bouchon de fermeture	Tapón de cierre
	1	1	1	1	1	1				
26	XGE 08-PLR 3/8						Verschraubung	Screwed connection	Raccord à vis	Atornillamiento
	1	1	1	1	1	1				
27	MU5300122						Hydraulikschlauch	hydraulic hose	Tuyau hydraulique	Tubo flexible hidráulico
	1	1	1	1	1	1				
28	MUMG0016						Rohrschelle	clamp	Collier	Abrazadera
	1	1	1	1	1	1				
29	MUMG0014						Deckplatte	cover plate	Plaque de recouvrement	Placa de revestimiento
	1	1	1	1	1	1				
30	MU0099999						Scheibe	washer	Disque	Arandela
	1	1	1	1	1	1				
31	MU980124						Schraube	bolt	Vis	Tornillo
	1	1	1	1	1	1				
32	MU0099961						Mutter	nut	Écrou	Tuerca
	1	1	1	1	1	1				
33	00019373						Scheibe	washer	Disque	Arandela
	8	8	8	8	8	8				



Getriebe-Eingangsdrehzahl | Input speed
 Vitesse d'entrée | Velocidad entrada | **1000 U / min**

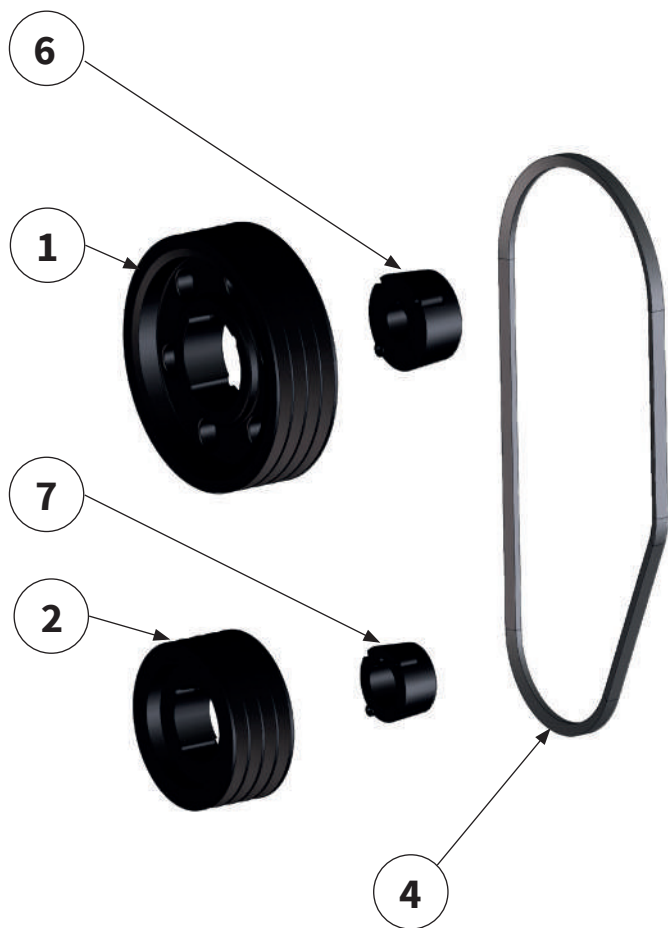

Getriebe-Eingangsdrehzahl | Input speed
 Vitesse d'entrée | Velocidad entrada | **750 U / min**

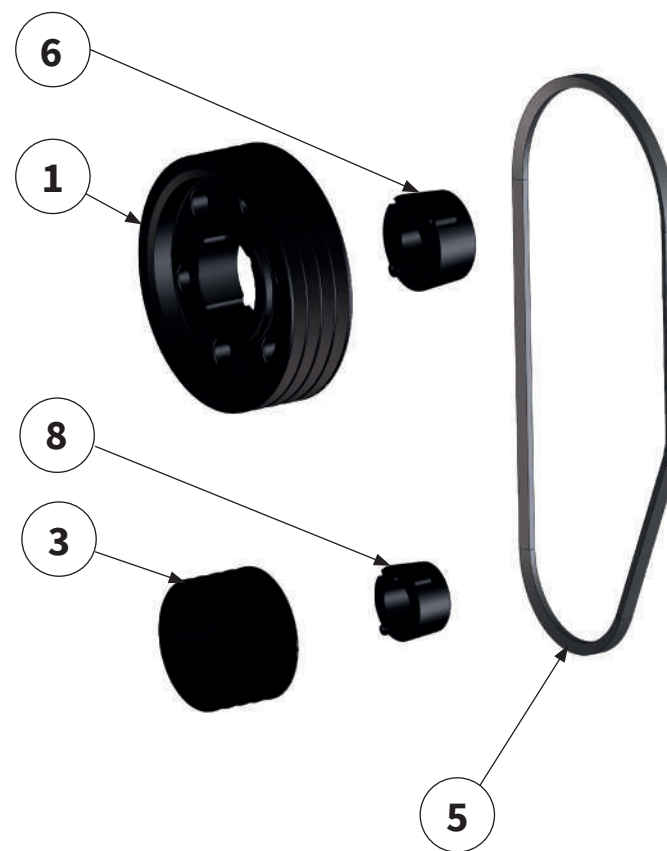

Pos.-Nr. No. Número Número	Ersatzteilnummer Manufacturer part number Numéro d'article du fabricant Número de pieza del fabricante						DE Bezeichnung	EN Designation	FR Désignation	ES Designación
	Anzahl quantity quantité número									
	MU-Pro 220	MU-Pro 250	MU-Pro 280	MU-Pro 280 mittig	MU-Pro 300	MU-Pro 320				
1	MU980863						Riemen- scheibe	belt pulley	Poulie	Polea
	1	1	1	1	1	1				
2	MU980894						Riemen- scheibe	belt pulley	Poulie	Polea
	1	1	1	1	1	1				
Getriebe-Eingangsdrehzahl Input speed Vitesse d'entrée Velocidad entrada 1000 U / min										
3	MU981906						Riemen- scheibe	belt pulley	Poulie	Polea
	1	1	1	1	1	1				
Getriebe-Eingangsdrehzahl Input speed Vitesse d'entrée Velocidad entrada 750 U / min										
4	MU981838						Keilriemen	V-belt	Courroie trapézoïdale	Correa trape- zoidal
	5	5	5	5	5	5				
Getriebe-Eingangsdrehzahl Input speed Vitesse d'entrée Velocidad entrada 1000 U / min										
5	XPB1650						Keilriemen	V-belt	Courroie trapézoïdale	Correa trape- zoidal
	5	5	5	5	5	5				
Getriebe-Eingangsdrehzahl Input speed Vitesse d'entrée Velocidad entrada 750 U / min										
6	MU980864						Buchse	clamping bush	Douille de serrage	Manguito de sujeción
	1	1	1	1	1	1				
7	MU980813						Buchse	clamping bush	Douille de serrage	Manguito de sujeción
	1	1	1	1	1	1				
Getriebe-Eingangsdrehzahl Input speed Vitesse d'entrée Velocidad entrada 1000 U / min										
8	MU981800						Buchse	clamping bush	Douille de serrage	Manguito de sujeción
	1	1	1	1	1	1				
Getriebe-Eingangsdrehzahl Input speed Vitesse d'entrée Velocidad entrada 750 U / min										



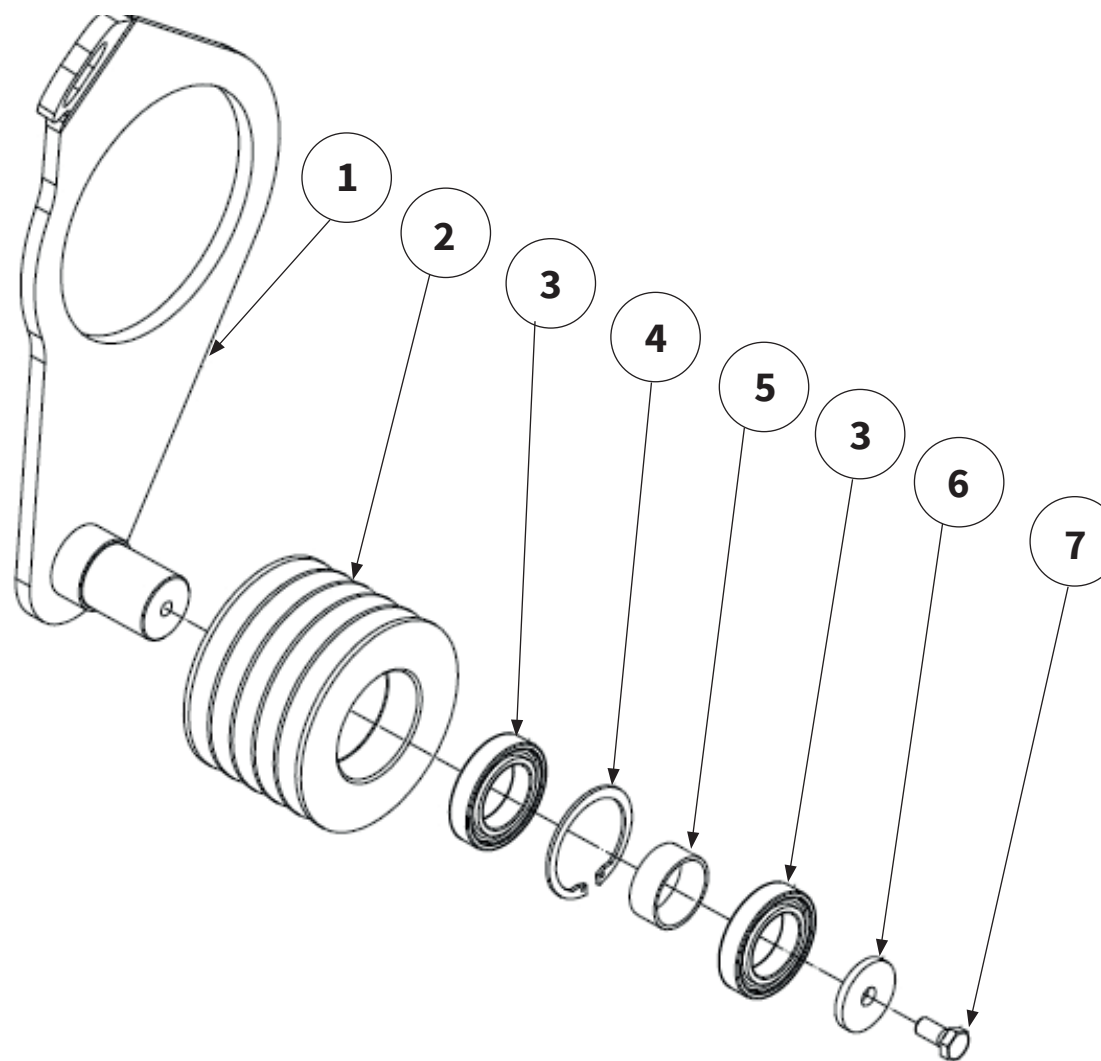

Pos.-Nr. No. Número	Ersatzteilnummer Manufacturer part number Numéro d'article du fabricant Número de pieza del fabricante						DE Bezeichnung	EN Designation	FR Désignation	ES Designación
	Anzahl quantity quantité número									
	MU-Pro 220	MU-Pro 250	MU-Pro 280	MU-Pro 280 mittig	MU-Pro 300	MU-Pro 320				
1	MUM00800						Spannhebel	Lever	Levier	Palanca
	1	1	1	1	1	1				
2	00003360						Spannrolle	idler pulley	Galet tendeur	Rodillo tensor
	1	1	1	1	1	1				
3	MU980897						Lager	bearing	Palier	Cojinete
	2	2	2	2	2	2				
4	MU980896						Sicherungsring	circlip	Bague de sécurité	Anillo de seguridad
	1	1	1	1	1	1				
5	MUM00600						Buchse	bushing	Manchon	Cojinete
	1	1	1	1	1	1				
6	MU0801808						Scheibe	washer	Disque	Arandela
	1	1	1	1	1	1				
7	MU980341						Schraube	bolt	Vis	Tornillo
	1	1	1	1	1	1				



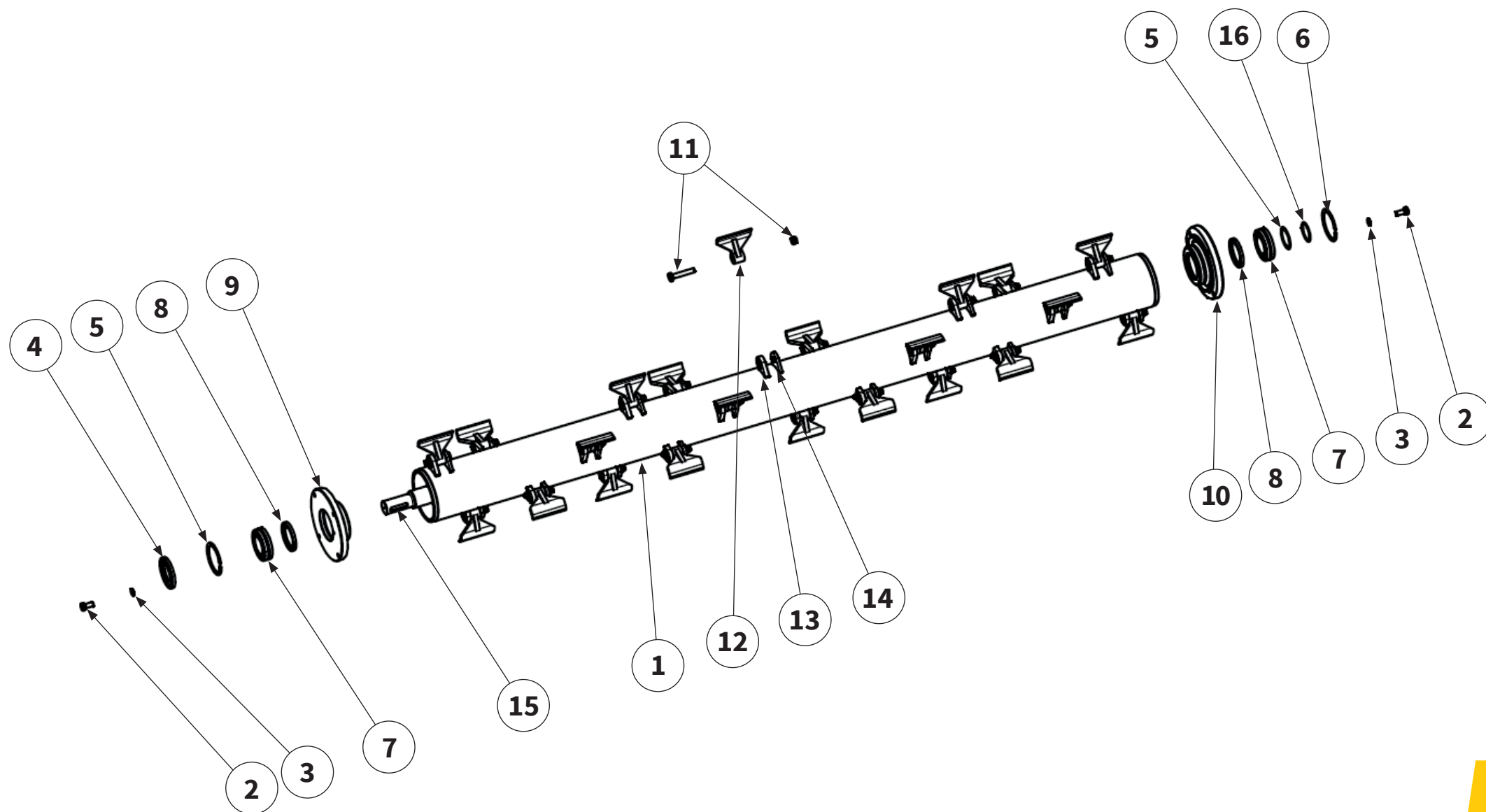

Pos.-Nr. No. Número	Ersatzteilnummer Manufacturer part number Numéro d'article du fabricant Número de pieza del fabricante						DE Bezeichnung	EN Designation	FR Désignation	ES Designación
	Anzahl quantity quantité número									
	MU-Pro 220	MU-Pro 250	MU-Pro 280	MU-Pro 280 mittig	MU-Pro 300	MU-Pro 320				
1	MU0206844 1	MU0203310 1	MU0203312 1 1		MU0203314 1	MU0204094 1	Rotor inkl. Werkzeug	rotor with tools	Rotor avec outils	Rotor con herram
2	8	8	8	8	8	8	Schraube	bolt	Vis	Tornillo
3	8	8	8	8	8	8	Scheibe	washer	Disque	Arandela
4	1	1	1	1	1	1	Wellendichtring	shaft seal	Bague à lèvres	Retén de eje
5	2	2	2	2	2	2	Sicherungsring	circlip	Bague de sécurité	Anillo de seguridad
6	1	1	1	1	1	1	Sicherungsring	circlip	Bague de sécurité	Anillo de seguridad
7	2	2	2	2	2	2	Lager	bearing	Palier	Cojinete
8	2	2	2	2	2	2	Wellendichtring	shaft seal	Bague à lèvres	Retén de eje
9	1	1	1	1	1	1	Rotorlager-schale	rotor bearing shell	Rotor coussinet	Cojinete del rotor
10	1	1	1	1	1	1	Rotorlager-schale	rotor bearing shell	Rotor coussinet	Cojinete del rotor
11	18	22	24	24	26	28	Schraube mit Mutter	bolt with nut	Vis avec écrou	Tornillo con tuerca
12	18	22	24	24	26	28	M-Hammer-schlegel	hammers	M-marteaux	Martillos



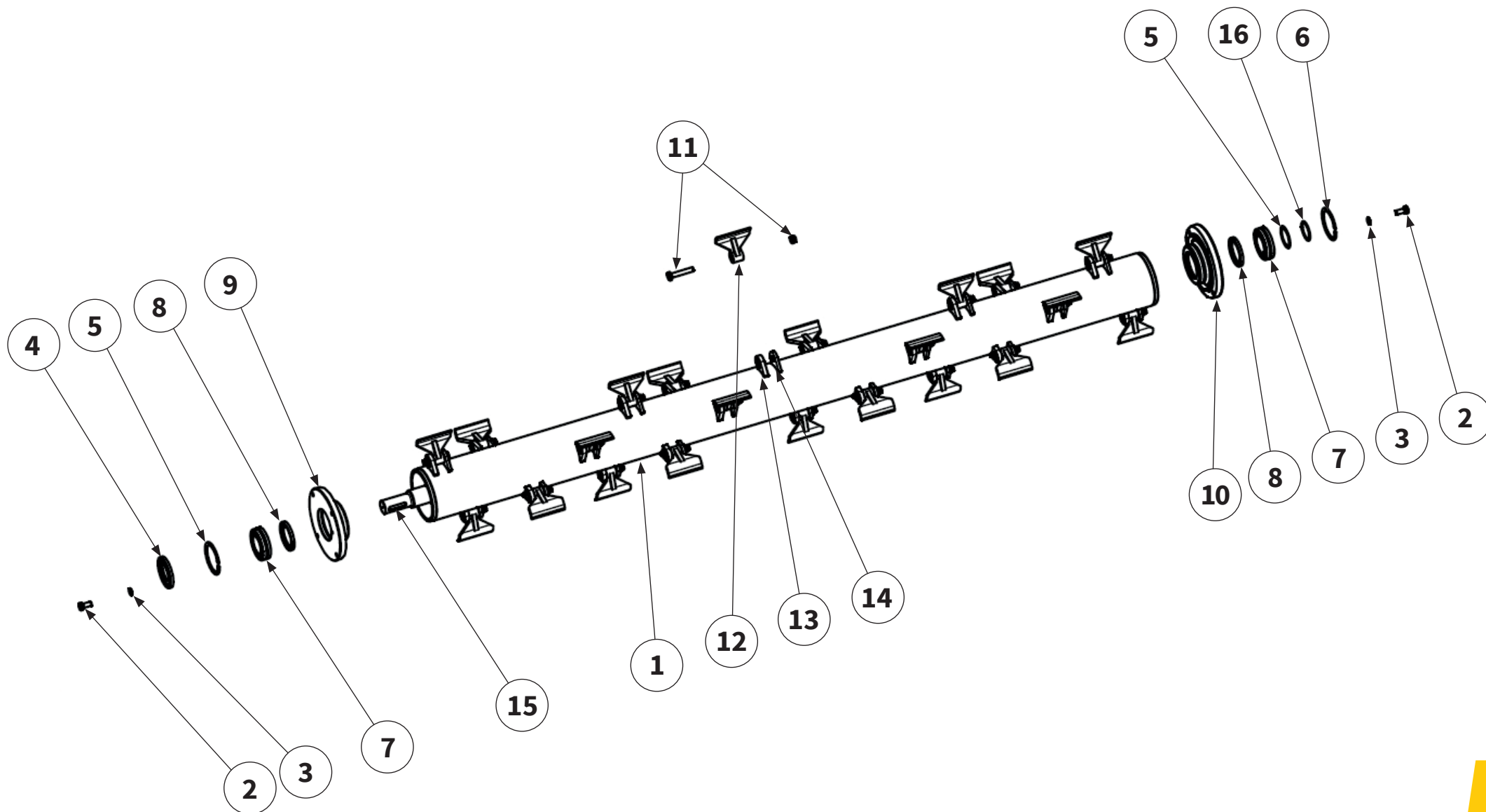

Pos.-Nr. No. Numéro Número	Ersatzteilnummer Manufacturer part number Numéro d'article du fabricant Número de pieza del fabricante						DE Bezeichnung	EN Designation	FR Désignation	ES Designación
	Anzahl quantity quantité número									
	MU-Pro 220	MU-Pro 250	MU-Pro 280	MU-Pro 280 mittig	MU-Pro 300	MU-Pro 320				
13	00013633						Werkzeug- halter	tool holder	Porte-outils	Porta herramientas
	18	22	24	24	26	228				
14	00013632						Werkzeug- halter mit Sechskant	tool holders with hexagon	Porte-outils à six pans forgé	Porta herra- mientas con hexagonal forjado
	18	22	24	24	26	28				
15	MU980860						Passfeder	parallel key	Clavette	Chaveta de ajuste
	1	1	1	1	1	1				
16	MU4145540						Paßscheibe	shim	Rondelle d'ajustage	Arandela de ajuste
	1	1	1	1	1	1				

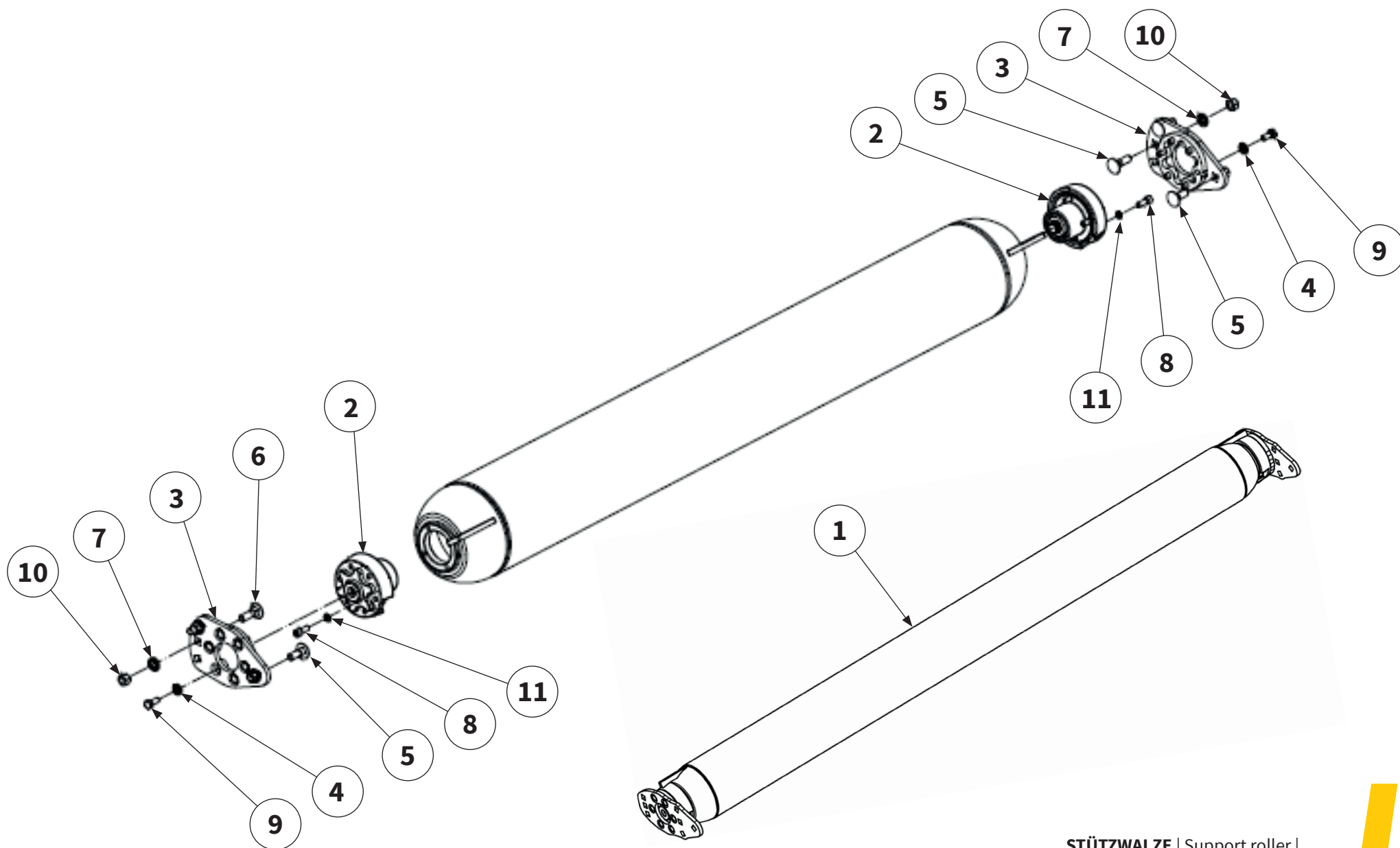

Pos.-Nr. No. Numéro Número	Ersatzteilnummer Manufacturer part number Numéro d'article du fabricant Número de pieza del fabricante						DE Bezeichnung	EN Designation	FR Désignation	ES Designación
	Anzahl quantity quantité número									
	MU-Pro 220	MU-Pro 250	MU-Pro 280	MU-Pro 280 mittig	MU-Pro 300	MU-Pro 320				
1	MU0206806 1	MU0206014 1	MU0205462 1 1		MU0205464 1	MU0206016 1	Stützwalze kpl.	support roller	Rouleau d'appui	Cilindro de apoyo
2	202932 2 2 2 2 2 2						Lagereinheit	bearing unit	Unité de palier	Unidad de rodamiento
3	MU0806403 2 2 2 2 2 2						Halteplatte	retainer plate	Plaque de support	Placa de retención
4	MUNSKL12 12 12 12 12 12 12						Scheibe	washer	Disque	Arandela
5	MU980424 2 2 2 2 2 2						Schraube	bolt	Vis	Tornillo
6	MU980428 4 4 4 4 4 4						Schraube	bolt	Vis	Tornillo
7	MUNSKL16 6 6 6 6 6 6						Scheibe	washer	Disque	Arandela
8	MU980315 8 8 8 8 8 8						Schraube	bolt	Vis	Tornillo
9	MU980307 12 12 12 12 12 12						Schraube	bolt	Vis	Tornillo
10	MU980401 6 6 6 6 6 6						Mutter	nut	Ècrou	Tuerca
11	MUNSKZ12 8 8 8 8 8 8						Scheibe	washer	Disque	Arandela



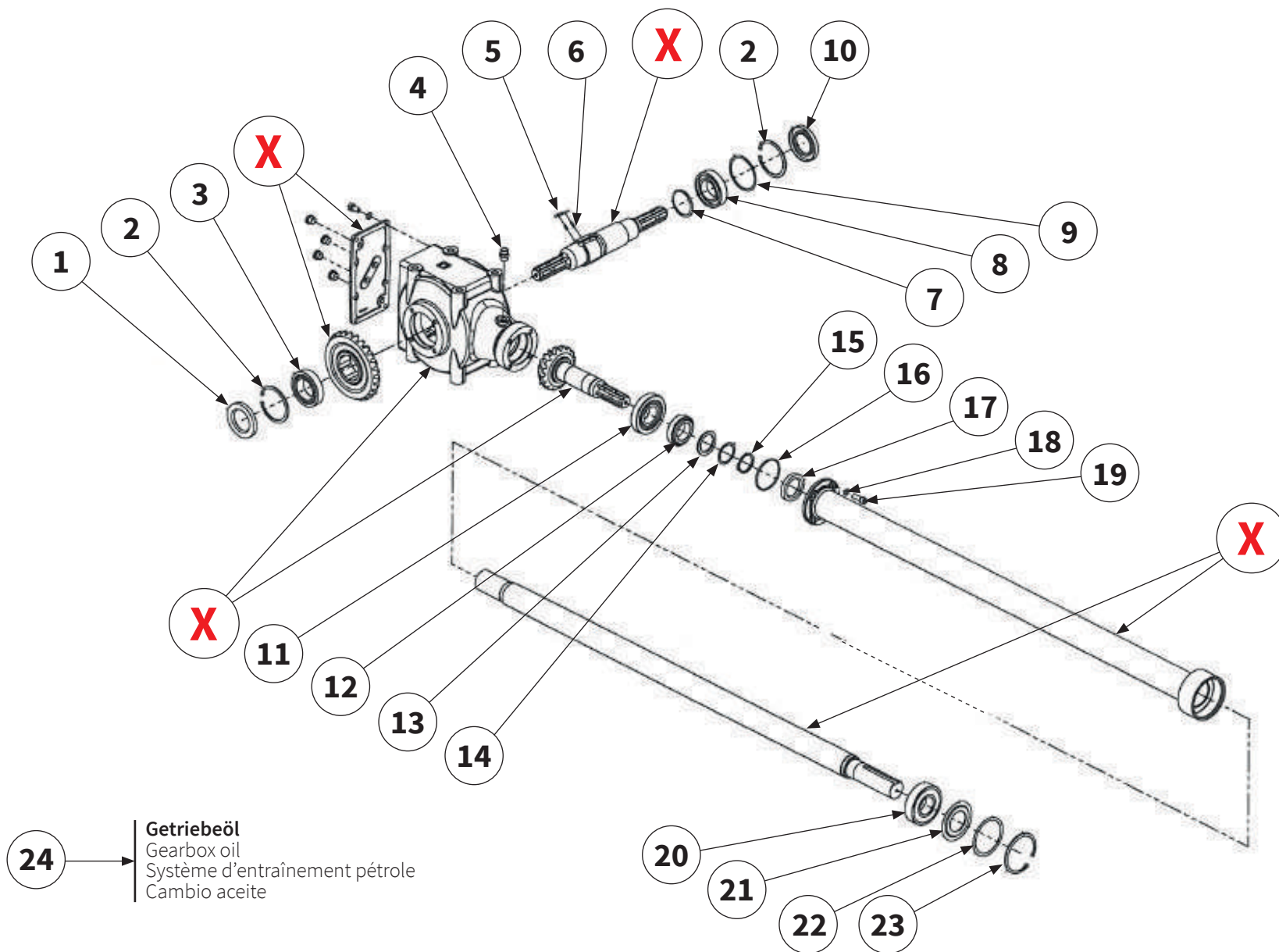

24 → **Getriebeöl**
 Gearbox oil
 Système d'entraînement pétrole
 Cambio aceite

Pos.-Nr. No. Numéro Número	Ersatzteilnummer Manufacturer part number Numéro d' article du fabricant Número de pieza del fabricante						DE Bezeichnung	EN Designation	FR Désignation	ES Designación
	Anzahl quantity quantité número									
	MU-Pro 220	MU-Pro 250	MU-Pro 280	MU-Pro 280 mittig	MU-Pro 300	MU-Pro 320				
1	MU980839						Wellen- dichtring	shaft sealing ring	Bague à lèvres	Retén de eje
2	MU490020						Innen- sicherungsring	circlip	Bague de sécurité	Anillo de seguridad
3	MU981109						Kegelrollen- lager	ball bearing	Palier à billes	Cojinete de bolas
4	MU623018						Getriebe- entlüftung	vent screw	Vis de purge d'air	Tornillo de purga de aire
5	MUS207006						Sperrklinke	detent freewheel	Cliquet d'arrêt roue libre	Trinquete de bloqueo rueda libre
6	MUS207005						Druckfeder	pressure spring	Ressort de pression	Muelle de presión
7	MU981820						Außen- sicherungsring	circlip	Bague de sécurité	Anillo de seguridad
8	00005842						Rillen- kugellager	deep-groove ball bearing	Roulement à billes rainuré	Cojinete ranurado de bolas
9	MU981003						Passscheibe	shim	Rondelle d'ajustage	Arandela de ajuste
10	00005844						Wellen- dichtring	shaft sealing ring	Bague à lèvres	Retén de eje
11	MU981104						Kegelrollen- lager	tapered roller bearing	Roulement à rouleaux coniques	Rodamiento de rodillos cónicos
12	MU981105						Kegelrollen- lager	tapered roller bearing	Roulement à rouleaux coniques	Rodamiento de rodillos cónicos
13	MU981004						Passscheibe	shim	Rondelle d'ajustage	Arandela de ajuste

X

Teile einzeln vom Hersteller nicht lieferbar | Parts from the manufacturer cannot be supplied individually |
Pièces non livrables séparément par le fabricant | El fabricante no suministra piezas individuales |

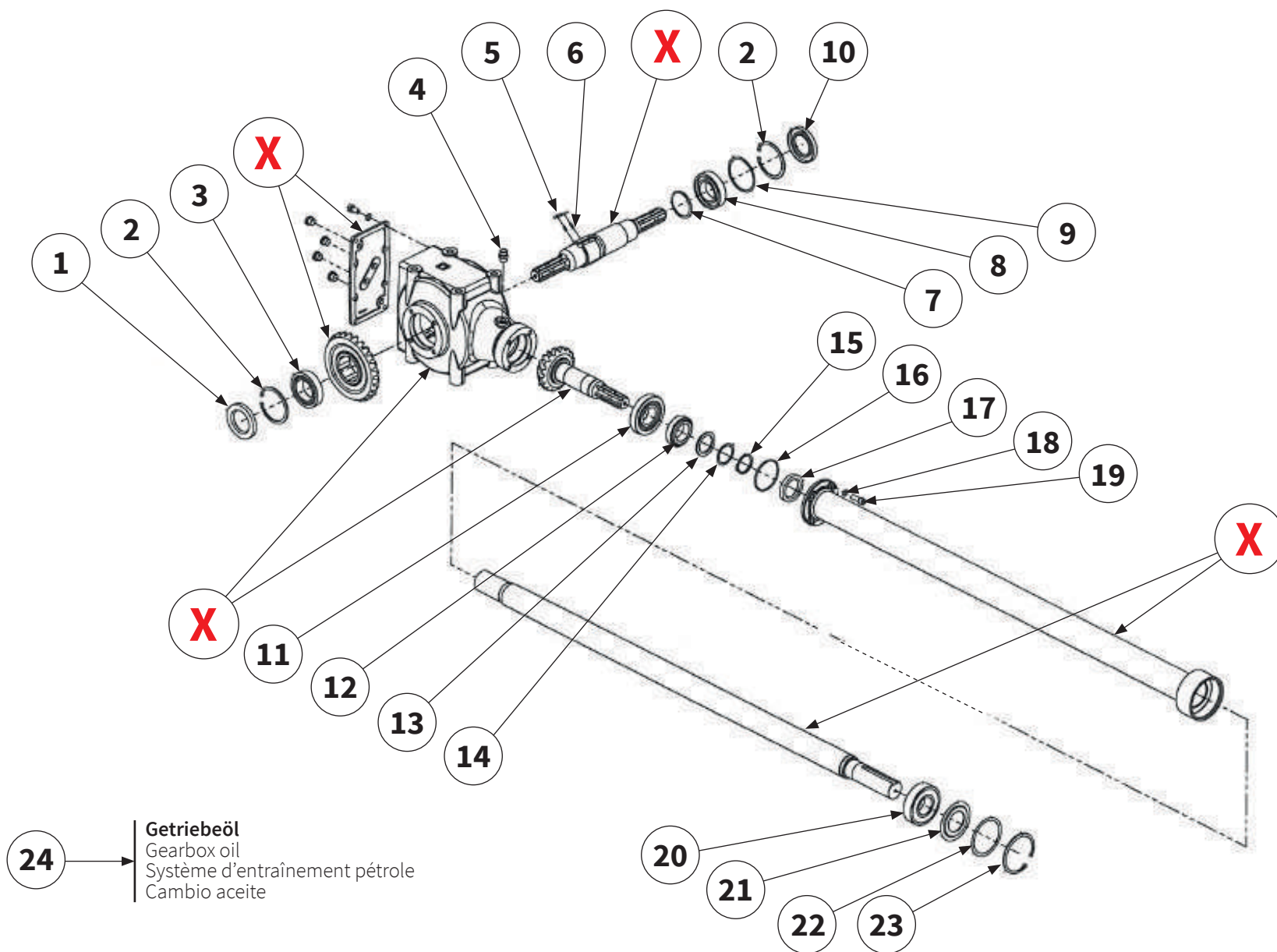

Getriebeöl
 Gearbox oil
 Système d'entraînement pétrole
 Cambio aceite

Pos.-Nr. No. Número	Ersatzteilnummer Manufacturer part number Numéro d'article du fabricant Número de pieza del fabricante						DE Bezeichnung	EN Designation	FR Désignation	ES Designación
	Anzahl quantity quantité número									
	MU-Pro 220	MU-Pro 250	MU-Pro 280	MU-Pro 280 mittig	MU-Pro 300	MU-Pro 320				
14	MU981005						Passscheibe	shim	Rondelle d'ajustage	Arandela de ajuste
	1	1	1	1	1	1				
15	MURV0035						Außensicherungsring	circlip	Bague de sécurité	Anillo de seguridad
	1	1	1	1	1	1				
16	MU981006						O-Ring	O-ring seal	joint torique	anillo tórico
	1	1	1	1	1	1				
17	MU981106						Wellendichtring	shaft sealing ring	Bague à lèvres	Retén de eje
	1	1	1	1	1	1				
18	MU980202						Scheibe	washer	Disque	Arandela
	4	4	4	4	4	4				
19	MU981245						Schraube	bolt	Vis	Tornillo
	4	4	4	4	4	4				
20	MU981107						Rillenkugellager	deep-groove ball bearing	Roulement à billes rainuré	Cojinete ranurado de bolas
	1	1	1	1	1	1				
21	00001842						Nilos Ring	bearing seal ring	Bague Nilos	Anillo Nilos
	1	1	1	1	1	1				
22	MU981007						Passscheibe	shim	Rondelle d'ajustage	Arandela de ajuste
	1	1	1	1	1	1				
23	MU980836						Innensicherungsring	circlip	Bague de sécurité	Anillo de seguridad
	1	1	1	1	1	1				
24	MUSAE70W90VS (1l)						Getriebeöl	gear box oil	Système d'entraînement pétrole	Cambio aceite
	3	3	3	3	3	3				
24a	2,5 l	2,5 l	2,5 l	2,5 l	2,5 l	2,5 l	Füllmenge	Oil fill quantity	Quantité d'huile	Cantidad de llenado de aceite
X	Teile einzeln vom Hersteller nicht lieferbar Parts from the manufacturer cannot be supplied individually Pièces non livrables séparément par le fabricant El fabricante no suministra piezas individuales									

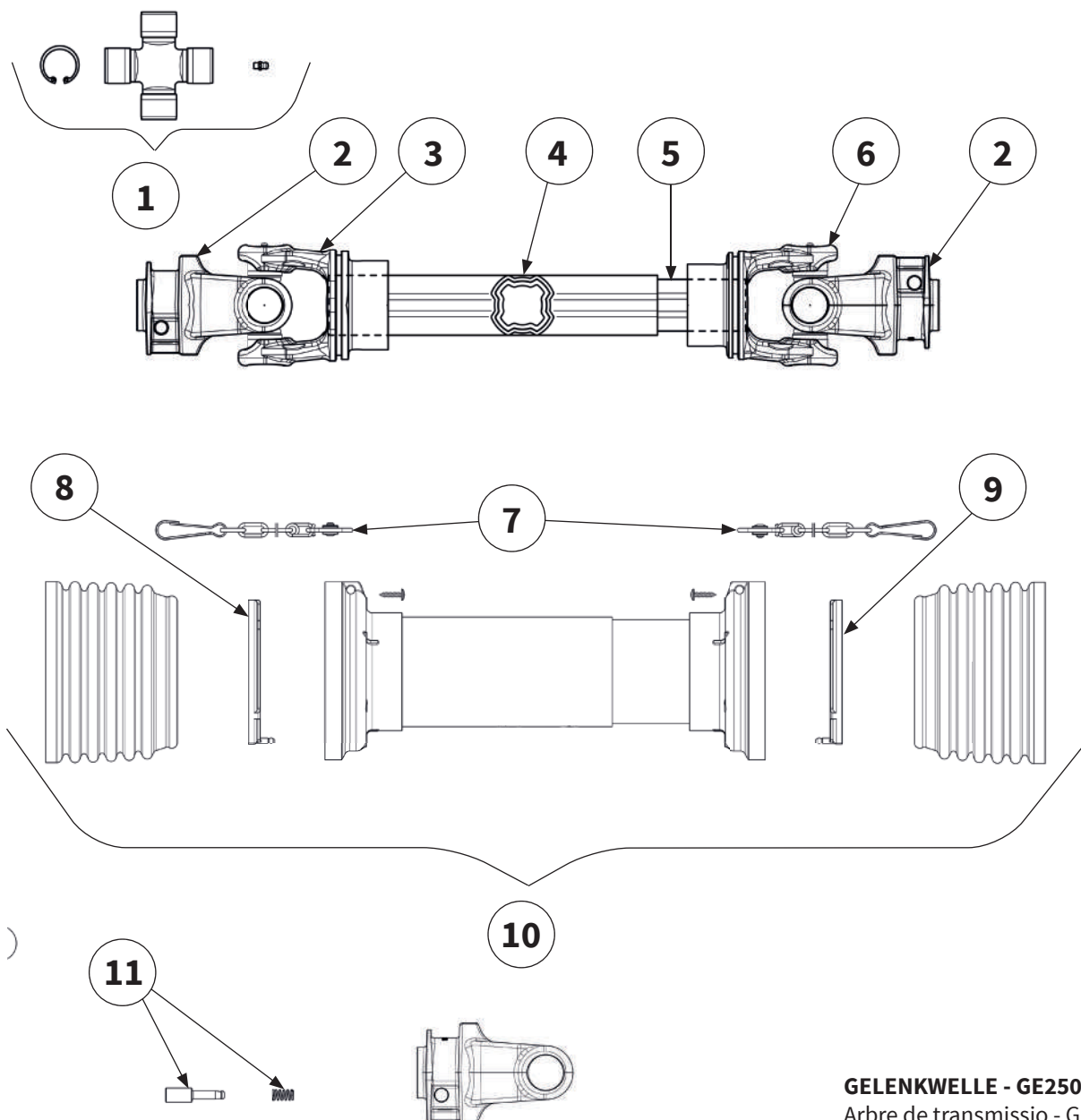

Pos.-Nr. No. Número	Ersatzteilnummer Manufacturer part number Numéro d'article du fabricant Número de pieza del fabricante						DE Bezeichnung	EN Designation	FR Désignation	ES Designación
	Anzahl quantity quantité número									
	MU-Pro 220	MU-Pro 250	MU-Pro 280	MU-Pro 280 mittig	MU-Pro 300	MU-Pro 320				
1	4120M0012R20						Kreuzgarnitur	Cross Kit	Croisillon	Crucetas
	2	2	2	2	2	2				
2	5070M0355						Außengabel	Outer Yoke	Mâchoire	Horquilla
	2	2	2	2	2	2				
3	204S96855						Innengabel für Außenrohr	Outer Yoke Teleskop-Tube	Mâchoire pour tube extérieur	Horquilla para tubo exterior
	1	1	1	1	1	1				
4	122111000R06						Profil-Außenrohr	Outer Telescope Tube	Tube externe	Tubo exterior
	1	1	1	1	1	1				
5	122381000R06						Profil-Innenrohr	Inner Telescope Tube	Tube interne	Tubo interior
	1	1	1	1	1	1				
6	204S96856						Innengabel für Innenrohr	Inner Yoke for Telescope Tube	Mâchoire pour tube intérieur	Horquilla para tubo interior
	1	1	1	1	1	1				
7	252000101R02						Haltekette	chain	Chaîne de retenue	Cadena de seguridad
	2	2	2	2	2	2				
8	2550L0001R02						Lauftring	Raceway	Palier de glissement	Anillo soporte
	1	1	1	1	1	1				
9	2550L0002R02						Lauftring	Raceway	Palier de glissement	Anillo soporte
	1	1	1	1	1	1				
10	5CS9086FXSS						Gelenkwellenschutz	Safety Shield complete	Protection contre les accidents	Protecciones de seguridad
	1	1	1	1	1	1				
11	403000032R10						Schiebestift	Push Pin Kit	Veru rapide	Pulsador
	2	2	2	2	2	2				



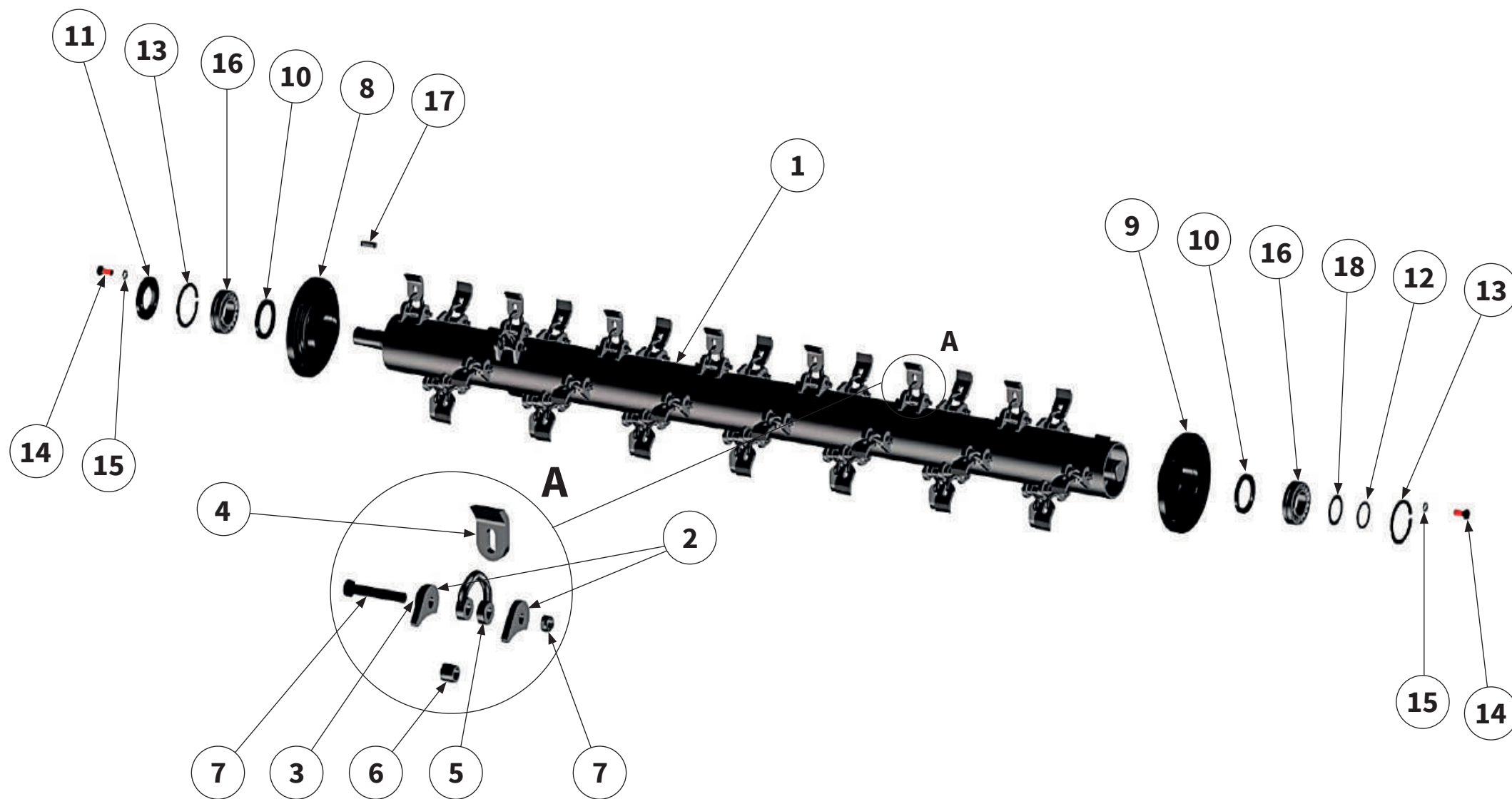

Pos.-Nr. No. Numéro Número	Ersatzteilnummer Manufacturer part number Numéro d'article du fabricant Número de pieza del fabricante						DE Bezeichnung	EN Designation	FR Désignation	ES Designación
	Anzahl quantity quantité número									
	MU-Pro 220	MU-Pro 250	MU-Pro 280	MU-Pro 280 mittig	MU-Pro 300	MU-Pro 320				
1	-	MU0200107 1	MU0200113 1 1		MU0200145 1	MU0204097 1	Schäkelrotor inkl. Werkzeug	rotor with tools	Rotor avec outils	Rotor con herram
2	-	104	116	MU000374 116	124	132	Werkzeug halter	tool holders	Porte-outils	Portaherra- mientas
3	-	52	58	MU000375 58	62	66	Verdreh- sicherung	anti-twist protection	Sécurité anti-torsion	Seguro contra giro
4	-	52	58	MU000449 58	62	66	Schäkel- messer	shackle flail	Lame de manille	Chuchilla del grillete
5	-	52	58	MU000507 58	62	66	Schäkel	shackle	Manille	Grillete
6	-	52	58	MU000560 58	62	66	Buchse	bushing	Manchon	Cojinete
7	-	52	58	MU980509 58	62	66	Schraube mit Mutter	bolt with nut	Vis avec Écrou	Tornillo con Tuerca
8	-	1	1	MUM00719 1	1	1	Rotor- halterung	rotor holder	Support de Rotor	Soporte del Rotor
9	-	1	1	MU3300182 1	1	1	Rotor- halterung	rotor holder	Support de Rotor	Soporte del Rotor
10	-	2	2	MU981850 2	2	2	Wellen- dichtring	shaft seal	Bague à lèvres	Retén de eje
11	-	1	1	MU980856 1	1	1	Wellen- dichtring	shaft seal	Bague à lèvres	Retén de eje

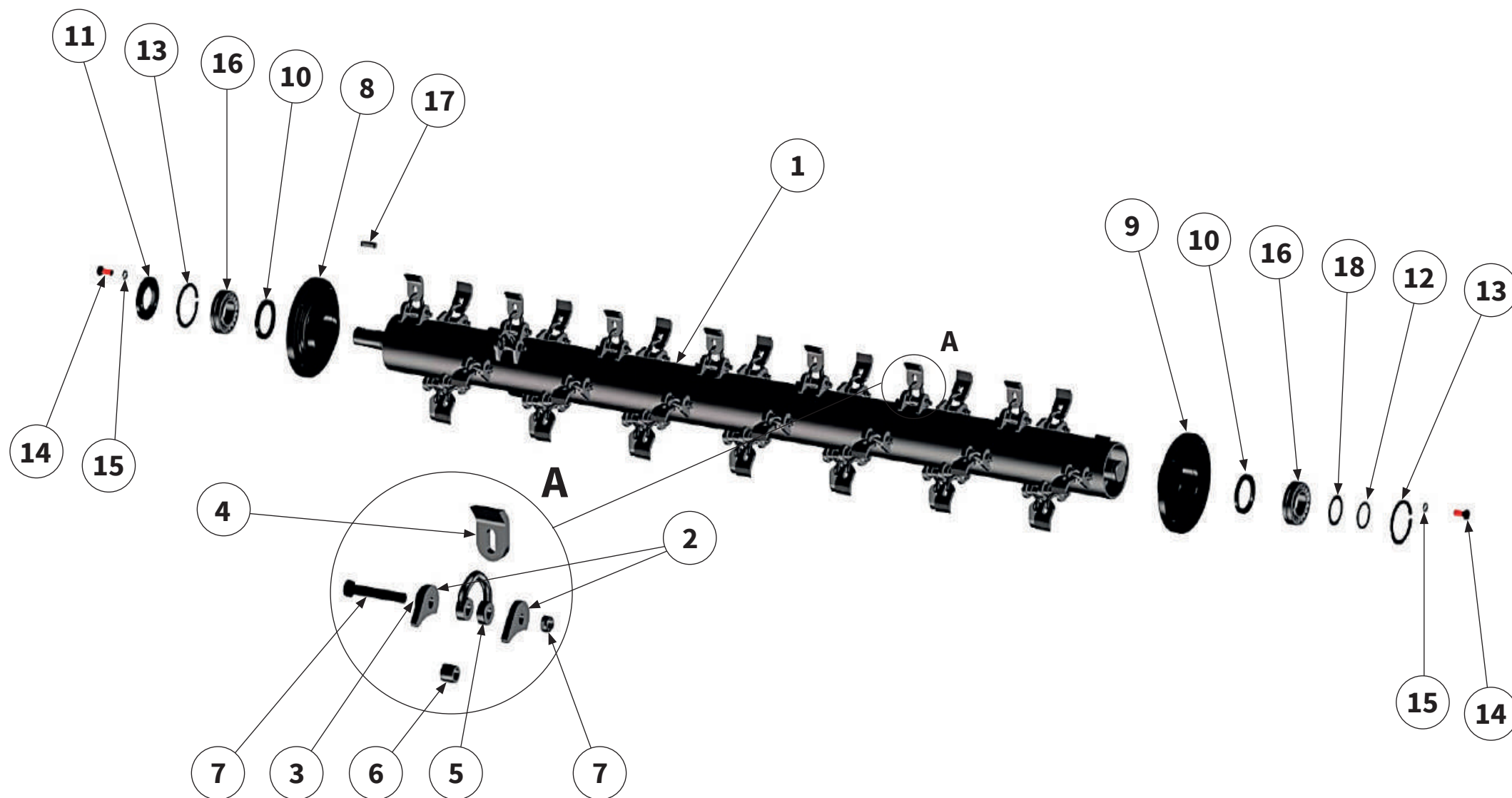

Pos.-Nr. No. Numéro Número	Ersatzteilnummer manufacturer part number Numéro d'article du fabricant Número de pieza del fabricante						DE Bezeichnung	EN Designation	FR Désignation	ES Designación
	Anzahl quantity quantité número									
	MU-Pro 220	MU-Pro 250	MU-Pro 280	MU-Pro 208 mittig	MU-Pro 300	MU-Pro 320				
12	-	1	1	1	1	1	Sicherungsring	circlip	Bague de sécurité	Anillo de seguridad
13	-	2	2	2	2	2	Sicherungsring	circlip	Bague de sécurité	Anillo de seguridad
14	-	8	8	8	8	8	Schraube	bolt	Vis	Tornillo
15	-	8	8	8	8	8	Scheibe	washer	Disque	Arandela
16	-	2	2	2	2	2	Lager	bearing	Palier	Conjinete
17	-	1	1	1	1	1	Passfeder	parallel key	Clavette	Chaveta de ajuste

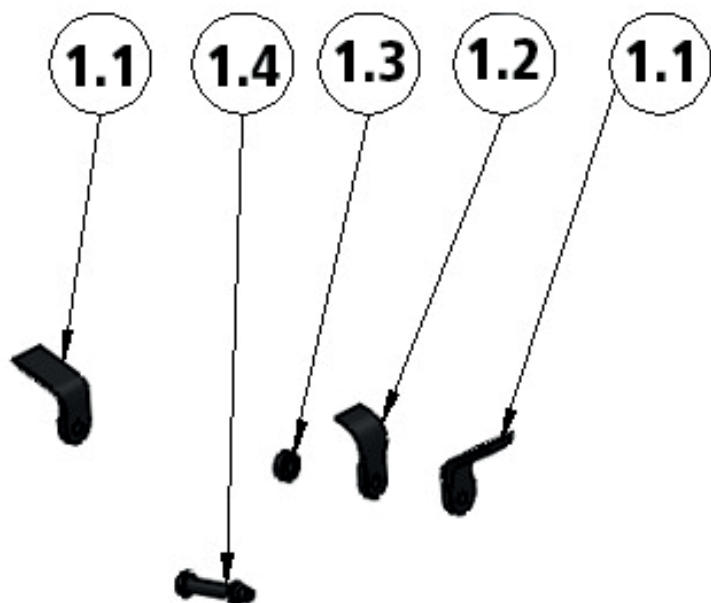

Pos.-Nr. No. Numéro Número	Ersatzteilnummer Manufacturer part number Numéro d'article du fabricant Número de pieza del fabricante						DE Bezeichnung	EN Designation	FR Désignation	ES Designación
	Anzahl quantity quantité número									
	MU-Pro 220	MU-Pro 250	MU-Pro 280	MU-Pro 280 mittig	MU-Pro 300	MU-Pro 320				
1.1	MU000557						Y-Messer	Y-blade	Couteau en Y action	Cuchilla en Y de hojas
	36	44	48	48	52	56				
1.2	MU000558						Y-Messer	Y-blade	Couteau en Y action	Cuchilla en Y de hojas
	18	22	24	24	26	28				
1.3	MU000559						Buchse	bushing	Manchon	Cojinete
	18	22	24	24	26	28				
1.4	MU980416-G						Schraube mit Mutter	bolt with nut	Vis avec Écrou	Tornillo con Tuerca
	18	22	24	24	26	28				



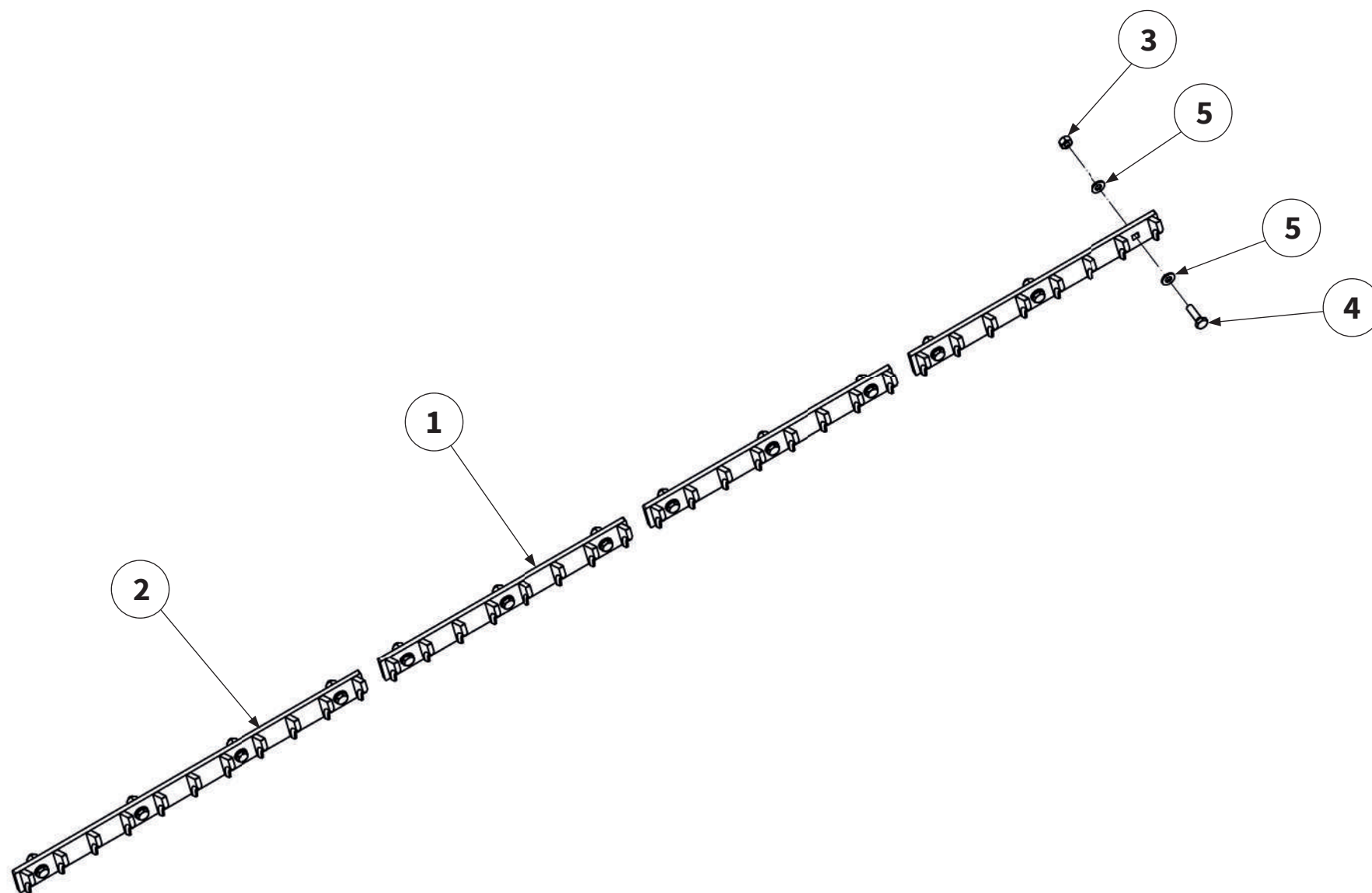

Pos.-Nr. No. Número	Ersatzteilnummer Manufacturer part number Numéro d'article du fabricant Número de pieza del fabricante						DE Bezeichnung	EN Designation	FR Désignation	ES Designación
	Anzahl quantity quantité número									
	MU-Pro 220	MU-Pro 250	MU-Pro 280	MU-Pro 280 mittig	MU-Pro 300	MU-Pro 320				
Maschine mit Hammerrotor Machine with Hammer rotor Machine avec Rotor à marteaux Máquina con Rotor de martillo 										
1	3	5	-	-	6	4	Gegen- schneide 400	short-chopping bar	Lame hache- paille courte	Listón de corte de paja corto
2	1	-	4	4	-	2	Gegen- schneide 600	short-chopping bar	Lame hache- paille courte	Listón de corte de paja corto
3	13	15	16	16	18	20	Schraube	bolt	Vis	Tornillo
4	26	30	32	32	36	40	Scheibe	washer	Disque	Arandela
5	13	15	16	16	18	20	Mutter	nut	Écrou	Tuerca
Maschine mit Schäkelrotor Machine with Shackle rotor Machine avec Rotor à manilles Máquina con Rotor de grilletes 										
1	3	5	-	-	6	4	Gegen- schneide 400	short-chopping bar	Lame hache- paille courte	Listón de corte de paja corto
2	1	-	4	4	-	2	Gegen- schneide 600	short-chopping bar	Lame hache- paille courte	Listón de corte de paja corto
3	13	15	16	16	18	20	Schraube	bolt	Vis	Tornillo
4	26	30	32	32	36	40	Scheibe	washer	Disque	Arandela
5	13	15	16	16	18	20	Mutter	nut	Écrou	Tuerca



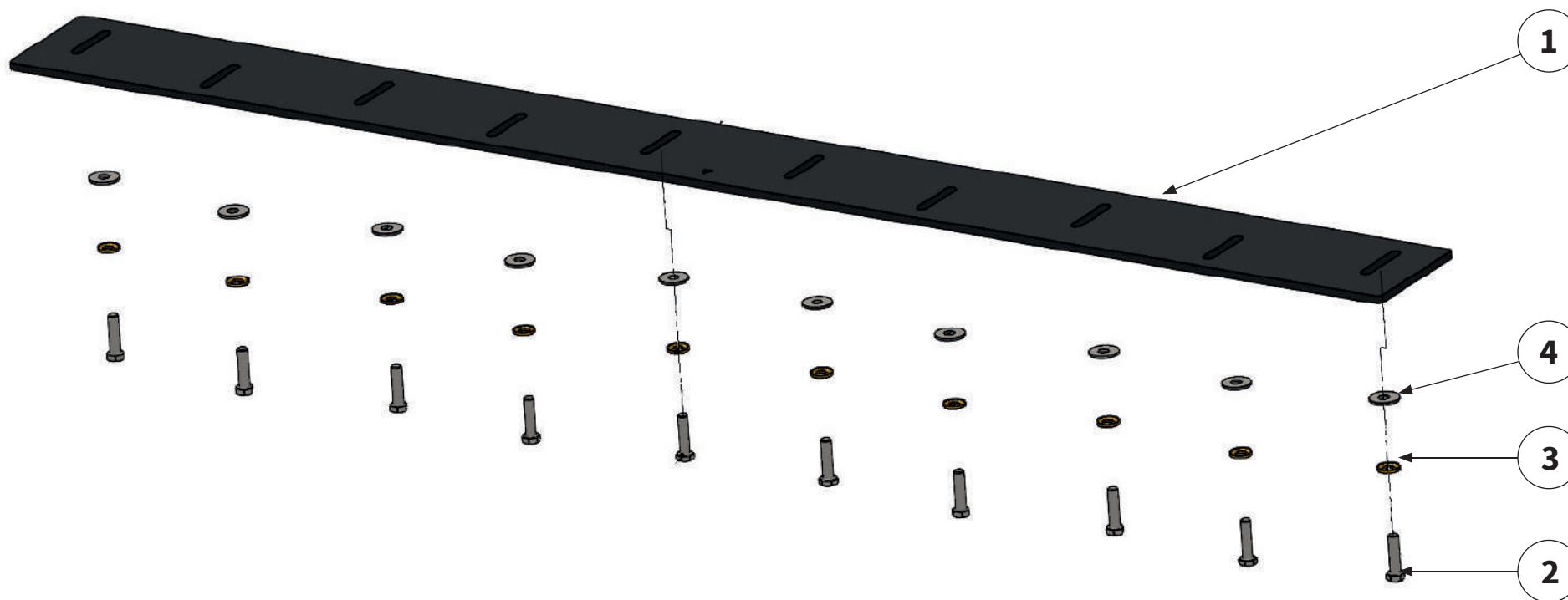

Pos.-Nr. No. Numéro Número	Ersatzteilnummer Manufacturer part number Numéro d'article du fabricant Número de pieza del fabricante						DE Bezeichnung	EN Designation	FR Désignation	ES Designación
	Anzahl quantity quantité número									
	MU-Pro 220	MU-Pro 250	MU-Pro 280	MU-Pro 280 mittig	MU-Pro 300	MU-Pro 320				
1	MU0912208 1	MU0912210 1	MU0910168 1 1		MU0910187 1	MU0913127 1	Schneidblech	cutting bar	Contre-lame réglable	Carril de corte
2	11	13	14	14	15	16	Schraube	bolt	Vis	Tornillo
3	11	13	14	14	15	16	Scheibe	washer	Disque	Arandela
4	11	13	14	14	15	16	Scheibe	washer	Disque	Arandela



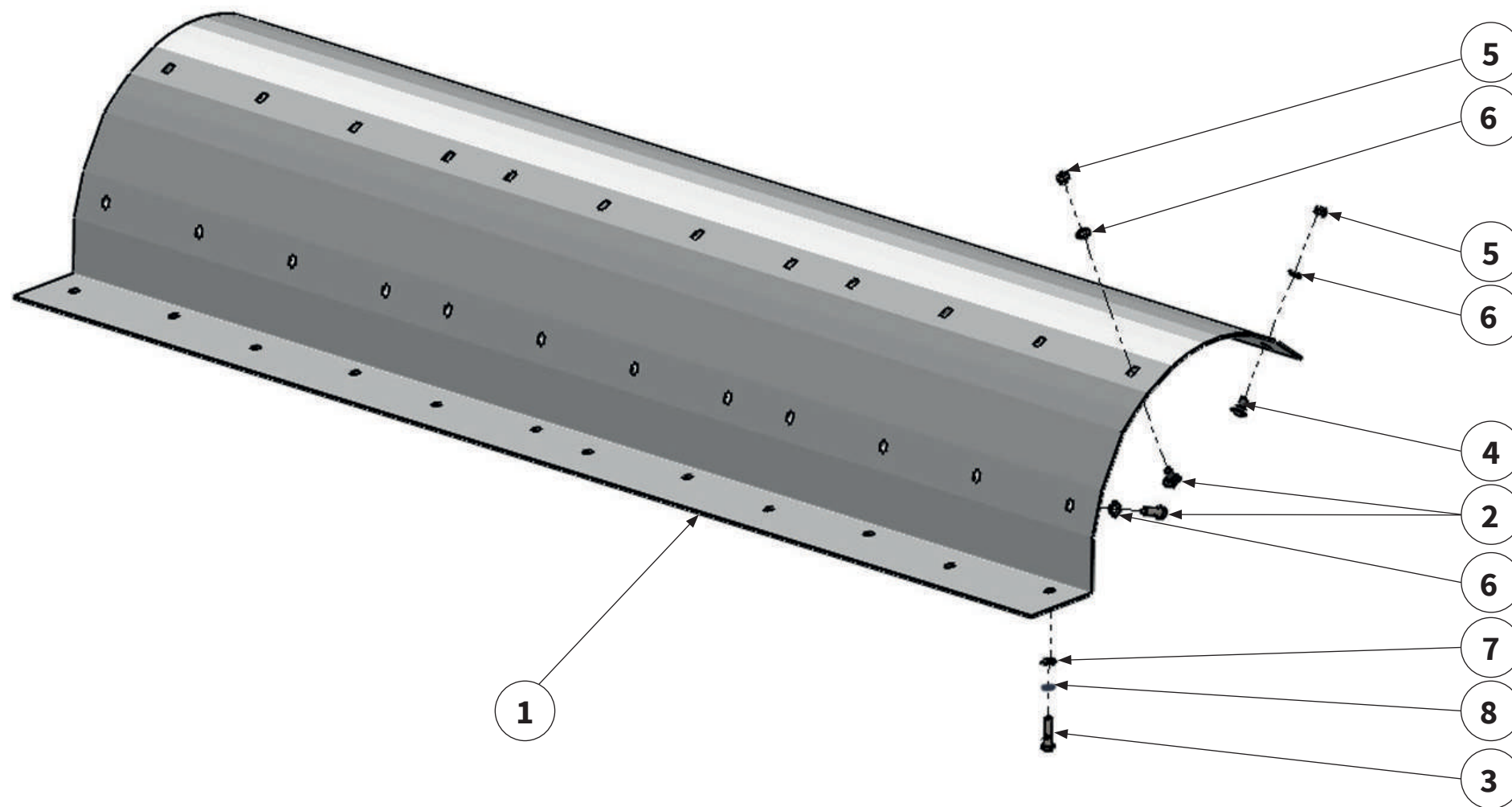

Pos.-Nr. No. Numéro Número	Ersatzteilnummer Manufacturer part number Numéro d'article du fabricant Número de pieza del fabricante						DE Bezeichnung	EN Designation	FR Désignation	ES Designación
	Anzahl quantity quantité número									
	MU-Pro 220	MU-Pro 250	MU-Pro 280	Mu-Pro 280 mittig	MU-Pro 300	MU-Pro 320				
1	MU0610134 1	MU0608461 1	MU0608015 1 1		MU0608592 1	MU0608463 1	Verschleiß- einlage	wear insert	Blindage	Junta de desgaste
2	26	28	30	30	33	36	Schraube	bolt	Vis	Tornillo
3	10	11	11	11	12	13	Schraube	bolt	Vis	Tornillo
4	14	15	16	16	18	20	Schraube	bolt	Vis	Tornillo
5	37	39	41	41	45	49	Mutter	nut	Écrou	Tuerca
6	37	39	41	41	45	49	Scheibe	washer	Disque	Arandela
7	14	15	16	16	18	20	Scheibe	washer	Disque	Arandela
8	10	11	11	11	12	13	Scheibe	washer	Disque	Arandela



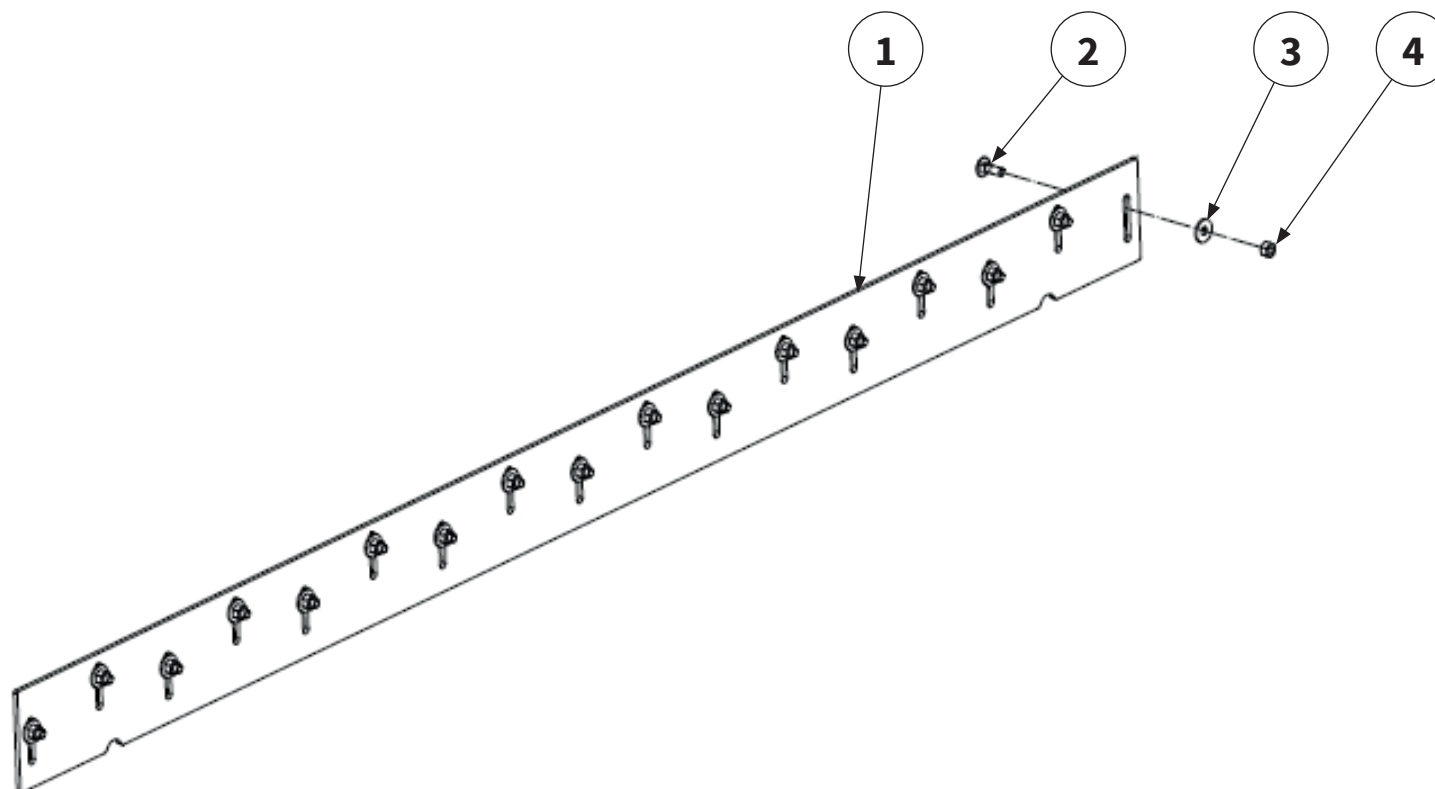

Pos.-Nr. No. Numéro Número	Ersatzteilnummer Manufacturer part number Numéro d'article du fabricant Número de pieza del fabricante						DE Bezeichnung	EN Designation	FR Désignation	ES Designación
	Anzahl quantity quantité número									
	MU-Pro 220	MU-Pro 250	MU-Pro 280	MU-Pro 280 mittig	MU-Pro 300	MU-Pro 320				
1	MU0914383 1	MU0608597 1	MU0912326 1 1		MU0912328 1	MU0912904 1	Abstreifer- schneide	Cleaner cutting edge	Lame de racloir	Cuchilla del rascador
2	00000904 17 19 21 21 25 25						Schraube	bolt	Vis	Tornillo
3	MU0099950 17 19 21 21 25 25						Scheibe	washer	Disque	Arandela
4	MU0099960 17 19 21 21 25 25						Mutter	nut	Écrou	Tuerca



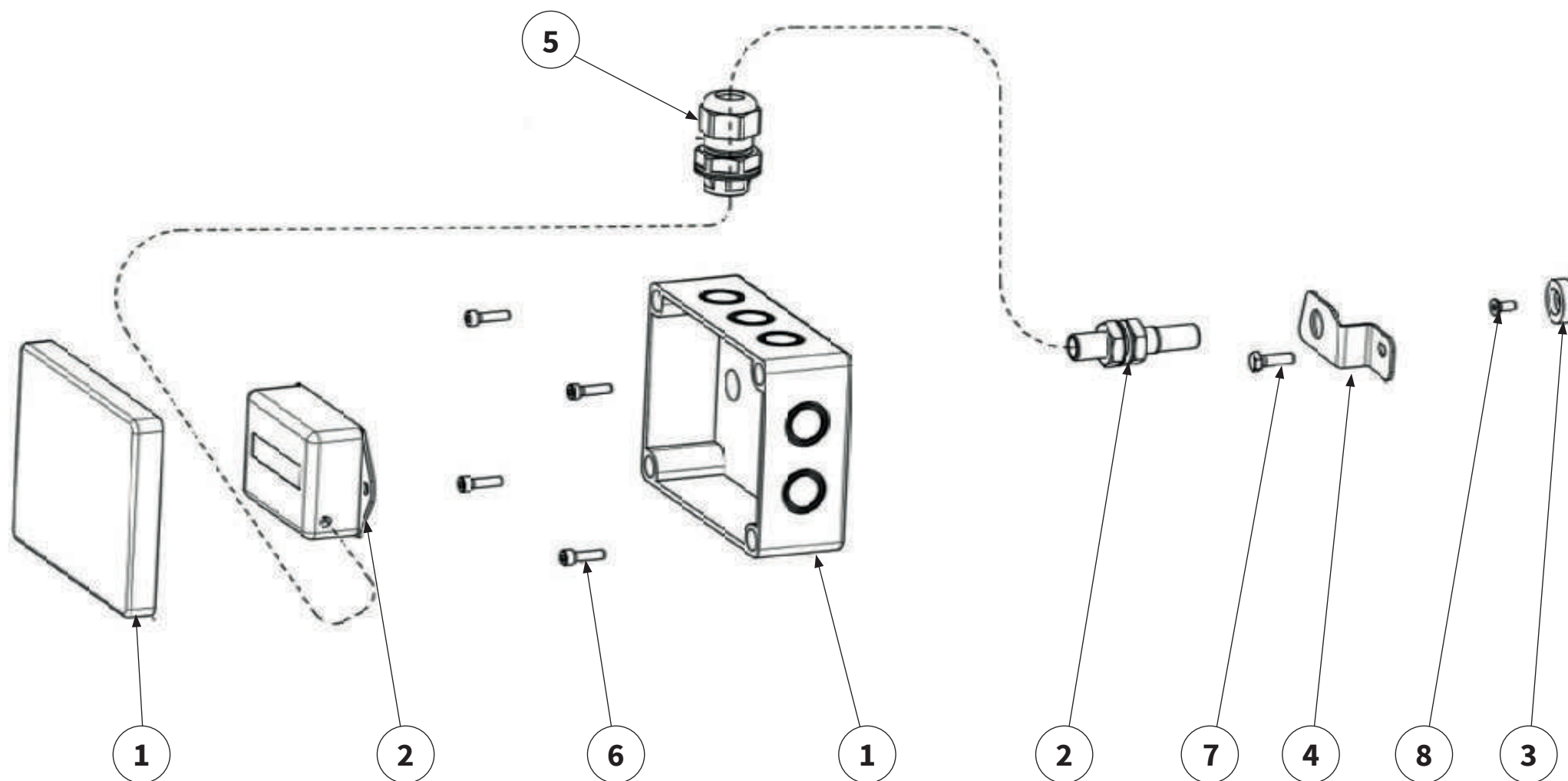

Pos.-Nr. No. Numéro Número	Ersatzteilnummer Manufacturer part number Numéro d'article du fabricant Número de pieza del fabricante						DE Bezeichnung	EN Designation	FR Désignation	ES Designación
	Anzahl quantity quantité número									
	MU-Pro 220	MU-Pro 250	MU-Pro 280	MU-Pro 280 mittig	MU-Pro 300	MU-Pro 320				
1	00010187						Verteiler- kasten	distribution box	Boîte de distri- bution	Caja de distribución
	1	1	1	1	1	1				
2	00015048						Betrieb- stunden- zähler	operating hours counter	Compteur horaire	Contador de horas de ser- vicio
	1	1	1	1	1	1				
3	00018168						Drehzahl- geber- magnet	engine speed sensor magnet	Régulateur de vitesse Aimant	Transmisor del número de revoluciones Imán
	1	1	1	1	1	1				
4	00017038						Sensor- halterung	holder	Support	Soporte
	1	1	1	1	1	1				
5	00008094						Verschrau- bung	Screwed con- nection	Raccord à vis	Atornillamiento
	1	1	1	1	1	1				
6	MU980005						Schraube	bolt	Vis	Tornillo
	4	4	4	4	4	4				
7	MU980001						Schraube	bolt	Vis	Tornillo
	1	1	1	1	1	1				
8	MU980007						Schraube	bolt	Vis	Tornillo
	1	1	1	1	1	1				



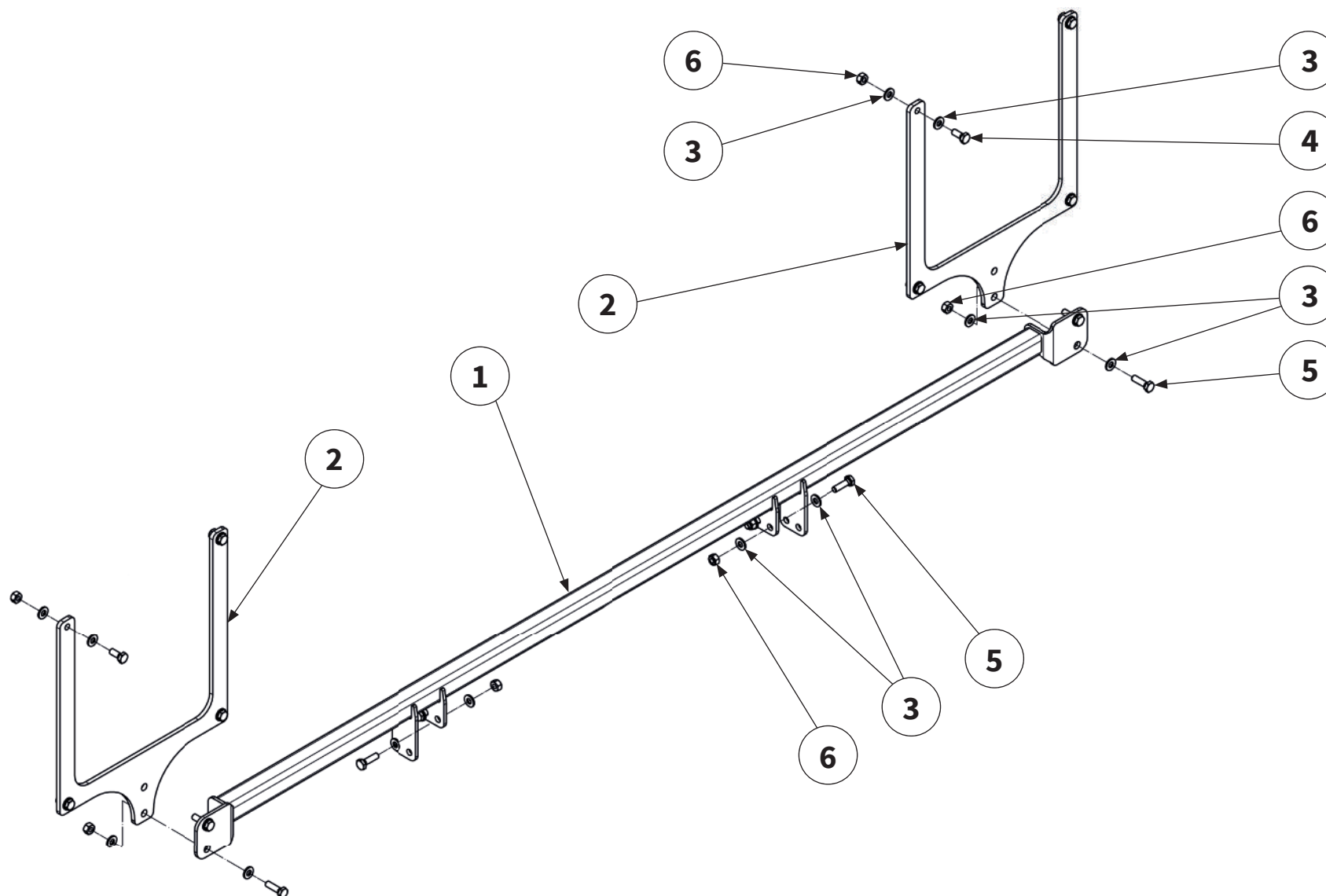

Pos.-Nr. No. numéro número	Ersatzteilnummer manufacturer Part number Numéro d'article du fabricant Número de pieza del fabricante						DE Bezeichnung	EN designation	FR désignation	ES designación
	Anzahl quantity quantité número									
	MU-Pro 220	MU-Pro 250	MU-Pro 280	MU-Pro 280 mittig	MU-Pro 300	MU-Pro 320				
1	MU0804782						Beleuchtungsträger	lightning equipment	Support d'éclairage	Soporte de alumbrado
	1	1	1	1	1	1				
2	MU0907933						Warntafelhalter	warning sign holder	Support de panneau de signalisation	Soporte del panel de aviso
	2	2	2	2	2	2				
3	MU980202						Scheibe	washer	Disque	Arandela
	32	32	32	32	32	32				
4	MU980208						Schraube	bolt	Vis	Tornillo
	8	8	8	8	8	8				
5	MU980222						Schraube	bolt	Vis	Tornillo
	8	8	8	8	8	8				
6	MU980201						Mutter	nut	Écrou	Tuerca
	16	16	16	16	16	16				



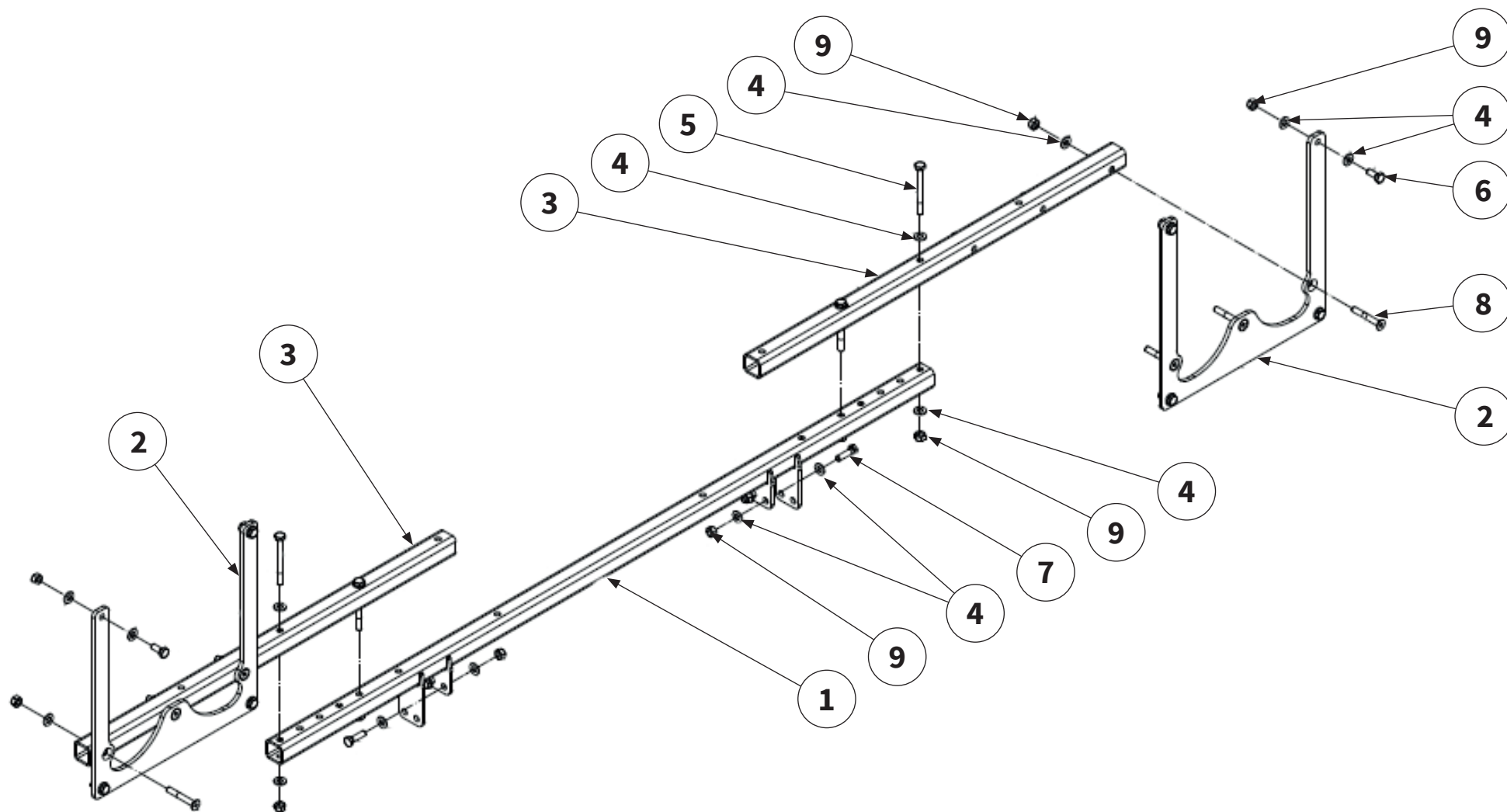

Pos.-Nr. No. Numéro Número	Ersatzteilnummer Manufacturer part number Numéro d'article du fabricant Número de pieza del fabricante						DE Bezeichnung	EN Designation	FR Désignation	ES Designación
	Anzahl quantity quantité número									
	MU-Pro 220	MU-Pro 250	MU-Pro 280	MU-Pro 280 mittig	MU-Pro 300	MU-Pro 320				
1	MU0807479						Beleuchtungs- träger	lighting equipment	Support d'éclairage	Soporte de alumbrado
	1	1	1	1	1	1				
2	MU0913053						Warntafel- halter	warning sign holder	Support de panneau de signalisation	Soporte del panel de aviso
	2	2	2	2	2	2				
3	MU1903097						Rechteckrohr	rectangular pipe	Tube rectangulaire	Tubo de sección rectangular
	2	2	2	2	2	2				
4	MU980202						Scheibe	washer	Disque	Arandela
	4	4	4	4	4	4				
5	MU980241						Schraube	bolt	Vis	Tornillo
	4	4	4	4	4	4				
6	MU980208						Schraube	bolt	Vis	Tornillo
	8	8	8	8	8	8				
7	MU980222						Schraube	bolt	Vis	Tornillo
	4	4	4	4	4	4				
8	MU981907						Schraube	bolt	Vis	Tornillo
	6	6	6	6	6	6				
9	MU0099960						Mutter	nut	Écrou	Tuerca
	22	22	22	22	22	22				

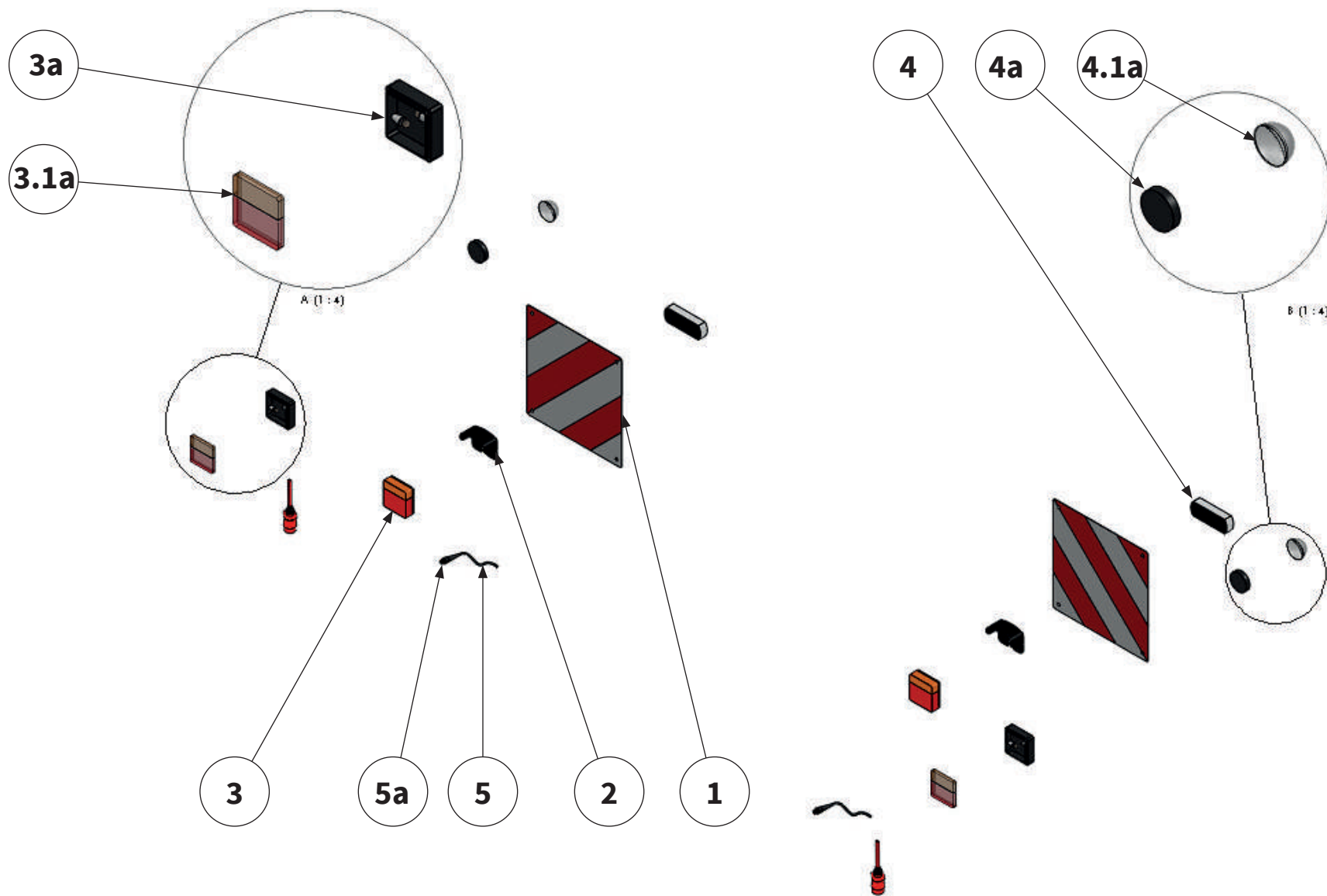

Pos.-Nr. No. Numéro Número	Ersatzteilnummer Manufacturer part number Numéro d'article du fabricant Número de pieza del fabricante						DE Bezeichnung	EN Designation	FR Désignation	ES Designación
	Anzahl quantity quantité número									
	MU-Pro 220	MU-Pro 250	MU-Pro 280	MU-Pro 280 mittig	Mu-Pro 300	MU-Pro 320				
1	R 1130/B						Warntafel	warning sign	Panneau de signalisation	Panel de aviso
2	308026-0230						Schutzabdeckung	protection cover	Recouvrement de protection	Cubierta protectora
3	3H3148-001						LED Blinkerleuchte	LED Direction indicator	LED- luminaire fclignotant	LED-lámpara intermitente
3a	319016-0020						Leuchte kpl.	light cpl.	Luminaire	Lámpara
3.1a	3L3348-002						Deckel	cap	Couvercle	Tapa
4	2P3158-011						LED Positionsleuchte	LED position light	LED position clignotant	LED Pilotos delanteros de posición
4a	319016-0021						Leuchte kpl.	light cpl.	Luminaire	Lámpara
4.1a	2L3348-001						Deckel	cap	Couvercle	Tapa
5	130400-016 (5m)						LED Verbindungskabel	LED connecting cable	LED câble de connexion	LED cable de conexión
5a	130400-014 (7m)									



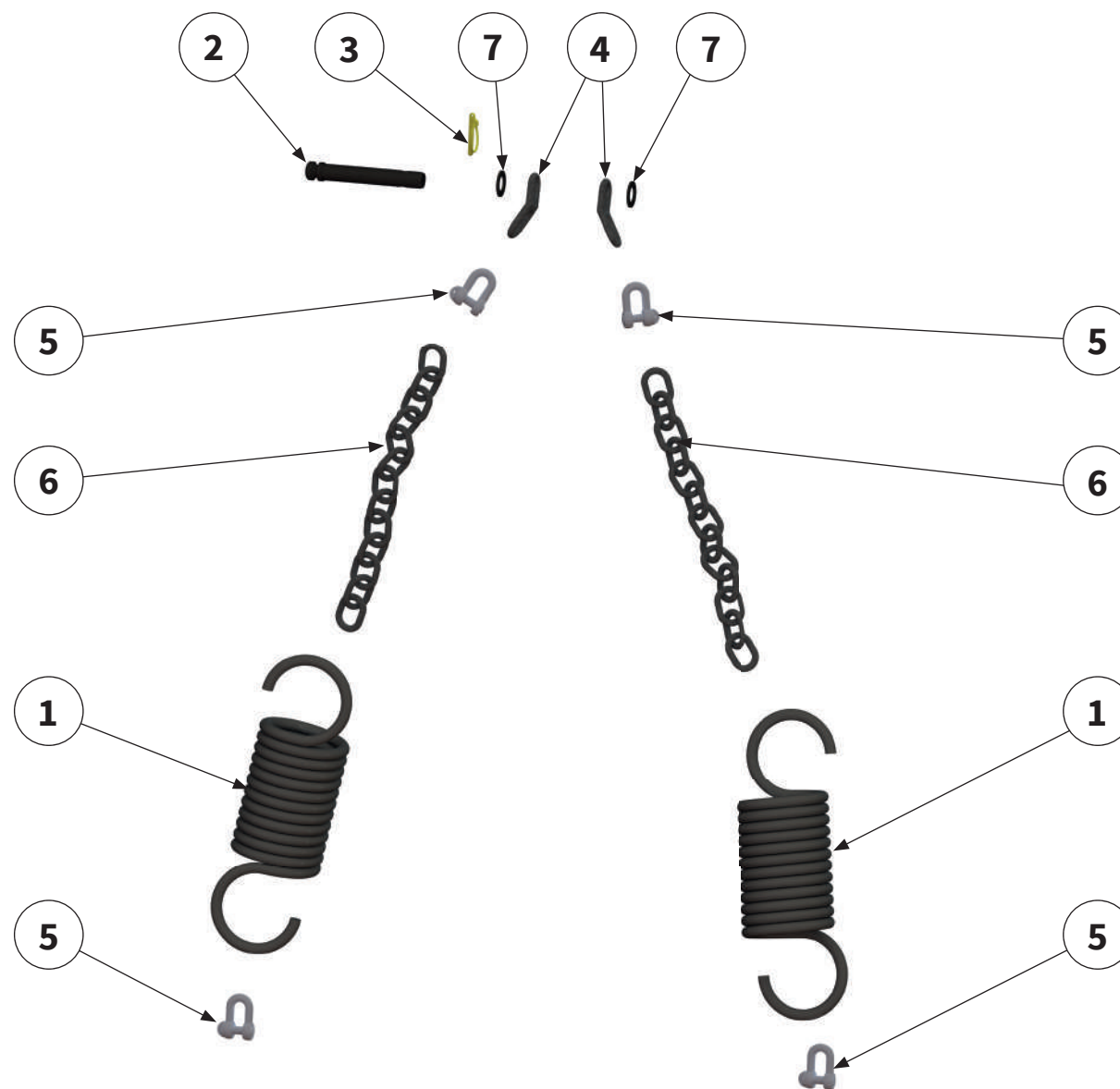

Pos.-Nr. No. Numéro Número	Ersatzteilnummer Manufacturer part number Numéro d'article du fabricant Número de pieza del fabricante						DE Bezeichnung	EN Designation	FR Désignation	ES Designación
	Anzahl quantity quantité número									
	MU-Pro 220	MU-Pro 250	MU-Pro 280	MU-Pro 280 mittig	MU-Pro 300	MU-Pro 320				
1	MUF00003						Zugfeder	tension spring	Ressort de traction	Resorte de tracción
	2	2	2	2	2	2				
2	OLB2136						Oberlenkerbolzen	pin	Axe	Perno
	1	1	1	1	1	1				
3	MFK 100						Klappstecker	lynch pin	Esse d'essieu	Pasador abatible
	1	1	1	1	1	1				
4	MUF00004						Verbindungsplatte	retainer plate	Plaque de support	Placa de retención
	2	2	2	2	2	2				
5	00006273						Schäkel	shackle	Manille	Grillete
	2	2	2	2	2	2				
6	MUF00005						Kette	chain	Chaîne	Cadena
	2	2	2	2	2	2				
7	MU980517						Scheibe	washer	Disque	Arandela
	2	2	2	2	2	2				



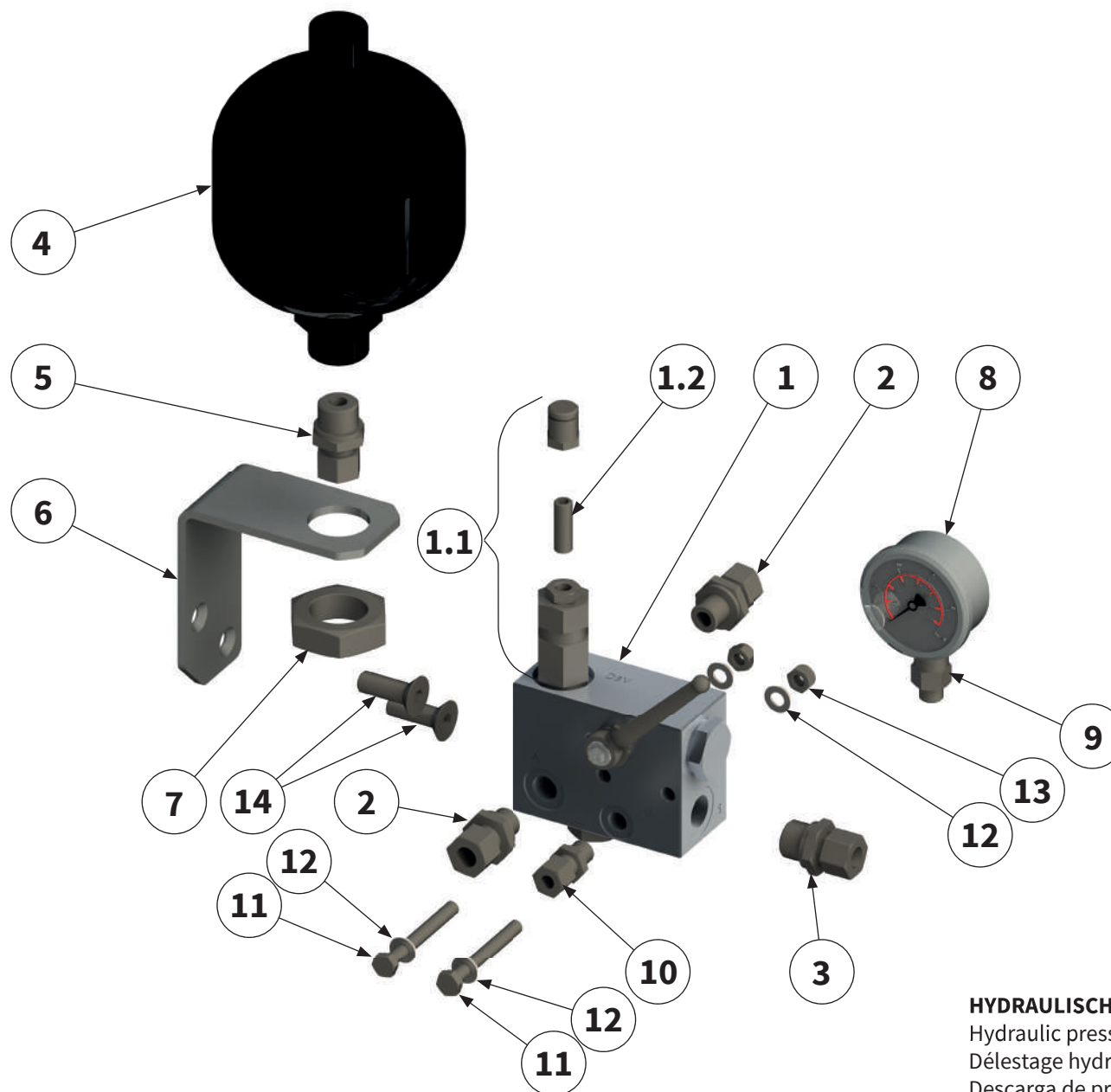

HYDRAULISCHE DRUCKENTLASTUNG MU-SOFA |
 Hydraulic pressure relief MU-SOFA |
 Délestage hydraulique MU-SOFA |
 Descarga de presión hidráulica MU-SOFA |

Pos.-Nr. No. Número	Ersatzteilnummer Manufacturer part number Numéro d'article du fabricant Número de pieza del fabricante						DE Bezeichnung	EN Designation	FR Désignation	ES Designación
	Anzahl quantity quantité número									
	MU-Pro 220	MU-Pro 250	MU-Pro 280	MU-Pro 280 mittig	MU-Pro 300	MU-Pro 320				
1	1552600						Ventilblock	Valve block	Bloc de soupapes	Bloque de válvulas
	1	1	1	1	1	1				
1.1	180352						Ventileinsatz	Valve core	Garniture de soupape	Inserto de válvula
	1	1	1	1	1	1				
1.2	209343						Gewindestift	threaded pin	Tige filetée	Perno roscado
	1	1	1	1	1	1				
2	GE-12-PLR-3/8						Verschraubung	Screwed connection	Raccord à vis	Atornillamiento
	2	2	2	2	2	2				
3	GE-12-PLR-1/2						Verschraubung	Screwed connection	Raccord à vis	Atornillamiento
	1	1	1	1	1	1				
4	209162						Stickstoffspeicher	Nitrogen accumulator	Poche d'azote	Burbuja de nitrógeno
	1	1	1	1	1	1				
5	GE-12-PLM-22x1,5						Verschraubung	Screwed connection	Raccord à vis	Atornillamiento
	1	1	1	1	2	1				
6	00009033						Haltewinkel	holder	Support	Soporte
	1	1	1	1	1	1				
7	00001159						Mutter	nut	Ecrou	Tuerca
	1	1	1	1	1	1				
8	112922						Manometer	Pressure gauge	Manomètre	Manómetro
	1	1	1	1	1	1				
9	MAV-LR08R1/4Zoll						Verschraubung	Screwed connection	Raccord à vis	Atornillamiento
	1	1	1	1	1	1				



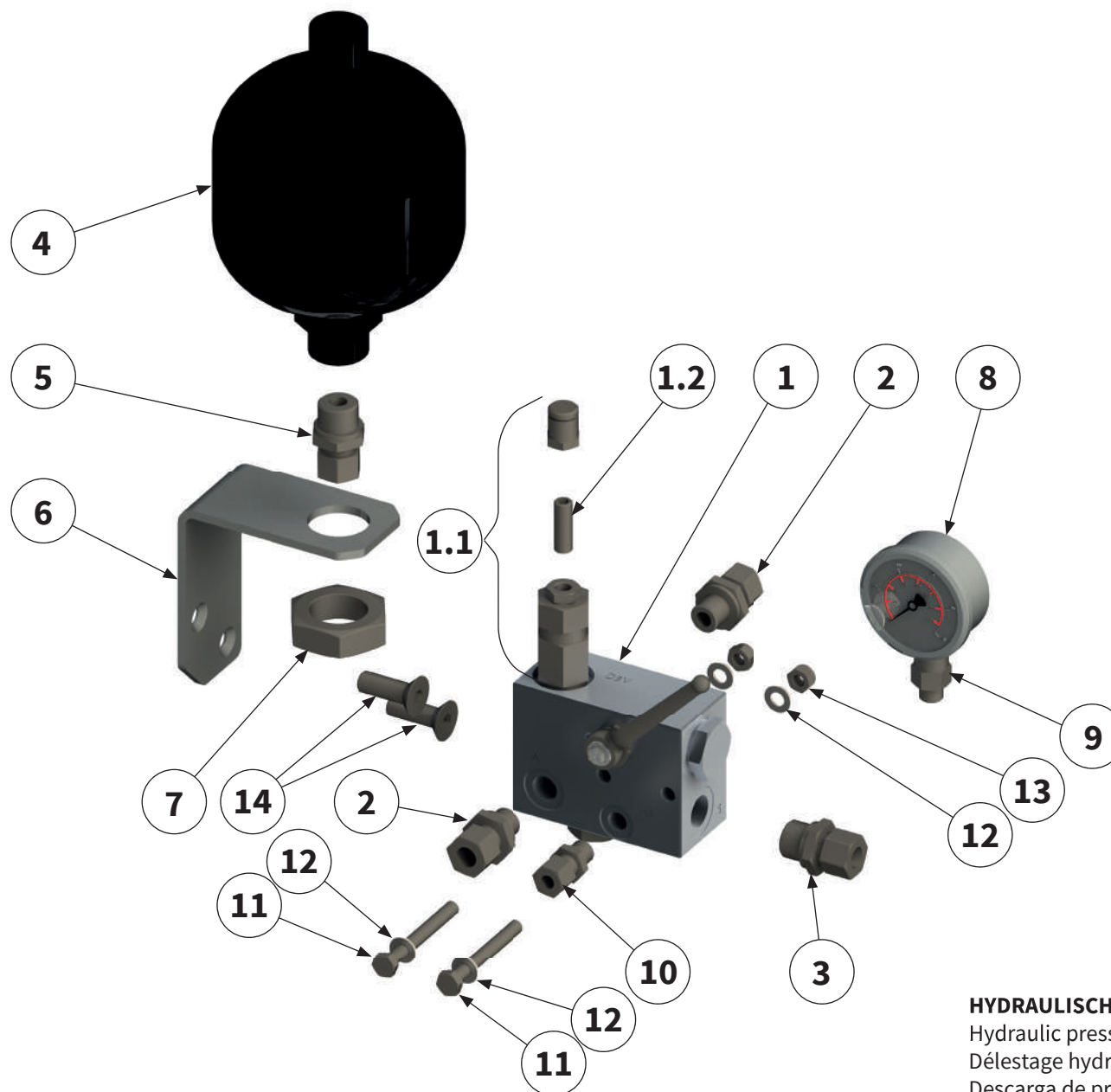

HYDRAULISCHE DRUCKENTLASTUNG MU-SOFA |
 Hydraulic pressure relief MU-SOFA |
 Délestage hydraulique MU-SOFA |
 Descarga de presión hidráulica MU-SOFA |

Pos.-Nr. No. Numéro Número	Ersatzteilnummer Manufacturer part number Numéro d'article du fabricant Número de pieza del fabricante						DE Bezeichnung	EN Designation	FR Désignation	ES Designación
	Anzahl quantity quantité número									
	MU-Pro 220	MU-Pro 250	MU-Pro 280	MU-Pro 280 mittig	MU-Pro 300	MU-Pro 320				
10	GE-08-PLR-1/4						Verschraubung	Screwed connection	Raccord à vis	Atornillamiento
	1	1	1	1	1	1				
11	MU980122						Schraube	bolt	Vis	Tornillo
	2	2	2	2	2	2				
12	MU0099999						Scheibe	washer	Disque	Arandela
	6	6	6	6	6	6				
13	MU0099961						Mutter	nut	Écrou	Tuerca
	4	4	4	4	4	4				
14	MU980134						Schraube	bolt	Vis	Tornillo
	2	2	2	2	2	2				

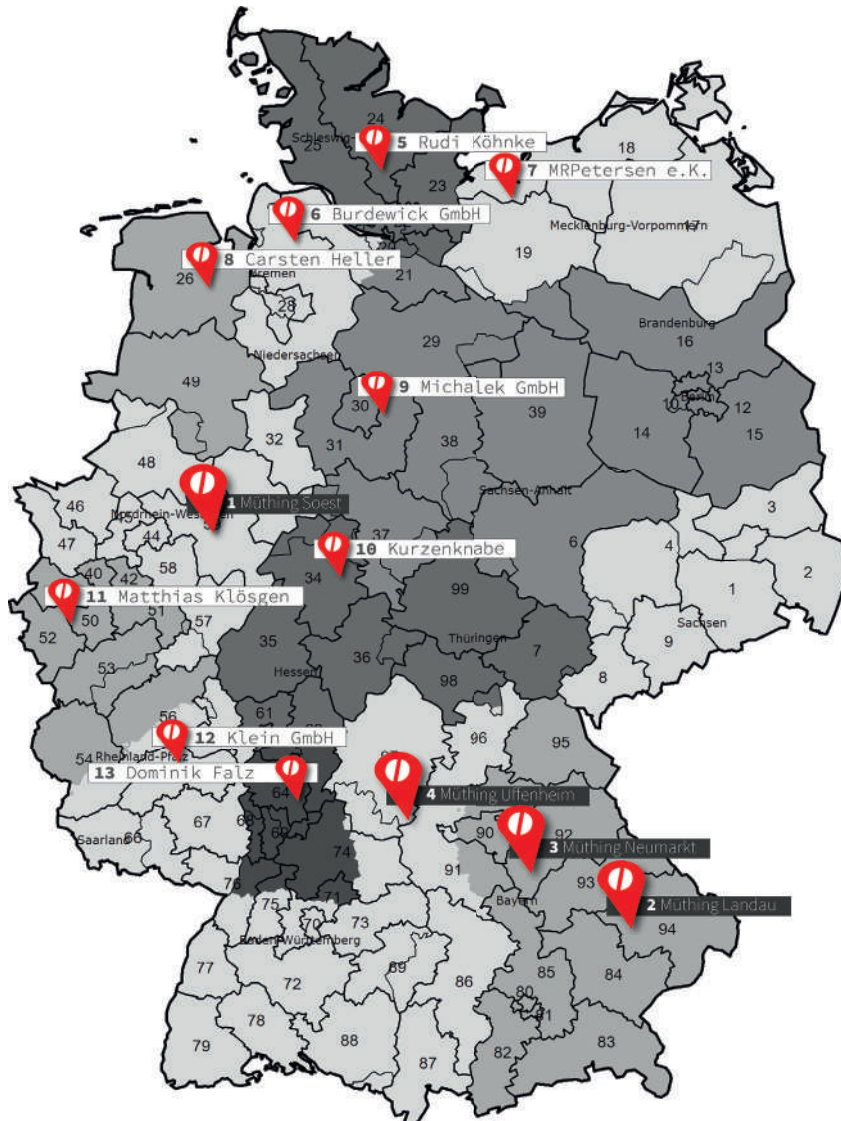

(1) Müthing GmbH & Co. KG Soest

Am Silberg 23
59494 Soest
Tel.: 02921 / 9651 - 0
Fax: 02921 / 73080
E-Mail: et-soest@muething.com

(2) Müthing GmbH & Co. KG Landau

Wiesenweg 6
94405 Landau
Tel.: 09951 / 6908 - 0
Fax: 09951 / 6333
E-Mail: et-landau@muething.com

(3) Müthing GmbH & Co. KG Neumarkt

Hans-Dehn-Str. 7
92318 Neumarkt
Tel.: 09181 / 2976 - 0
Fax: 09181 / 21841
E-Mail: neumarkt@muething.com

(4) Müthing GmbH & Co. KG Uffenheim

Am Brunnlein 2
97215 Uffenheim
Tel.: 09842 / 9866 - 0
Fax: 09842 / 9866 - 67
E-Mail: et-uff@muething.com

(5) Rudi Köhnke

Wohldweg 16
24558 Henstedt-Ulzburg
Tel.: 04193 / 91544
Fax: 04193 / 759576
E-Mail: krkoehnke@aol.com

(6) Burdewick GmbH

Mittelstenaher Str. 33
21769 Lamstedt
Tel.: 04773 / 8941 - 0
Fax: 04773 / 8941 - 41
E-Mail: info@burdewick.de

(7) MRPetersen e.K. Werksvertretung

Christiansburger Weg 20
24969 Lindewitt / OT Sillerup
Tel.: 04604 / 9866 - 36
Fax: 04604 / 9866 - 37
E-Mail: rp@mrpetersen.de

(8) Müthing GmbH & Co. KG Soest - Carsten Heller Werksbeauftragter

Tel.: 0160 / 96919245
Fax: 04461 / 759302
E-Mail: c.heller@muething.com

(9) Michalek GmbH

Industriestraße 14
31275 Lehrte
Tel.: 05132 / 2006 - 0
Fax: 05132 / 2006 - 30
E-Mail: info@michalek-ww.de

(10) Kurzenknabe

Obervellmarer Weg 36
34314 Espenau
Tel.: 05673 / 4012
Fax: 05673 / 2495
E-Mail: info@kurzenknabe-gmbh.de

(11) Matthias Klösigen

Drovestrasse 104
52372 Kreuzau
Tel.: 02422 / 9019 - 25
Fax: 02422 / 9019 - 26
E-Mail: matthias.kloesgen@t-online.de

(12) Klein GmbH

Hauptstraße 2
55627 Weiler / Nahe
Tel.: 06754 / 404
Fax: 06754 / 643
E-Mail: klein-ww-weiler@t-online.de

(13) Dominik Falz

Carl-Benz- Str. 4
64711 Erbach / Odw.
Tel.: 06062 / 1867
Fax: 06062 / 61851
E-Mail: d.falz@muething-mulcher.de

Bei weiteren Fragen zu Technik und Einsatz Ihres Gerätes stehen Ihnen unsere Mitarbeiter oder unsere Vertriebspartner gerne zur Verfügung.

Our employees or sales partners are happy to help should you have any further questions on the technical aspects and use of your implement.

Nos collaborateurs ou nos partenaires commerciaux sont à votre entière disposition pour toutes questions complémentaires relatives aux caractéristiques techniques ou à l'utilisation de votre engin.

Tanto nuestros empleados como los socios comerciales de la marca estamos a su disposición para atender cualquier consulta técnica o sobre piezas que pueda tener respecto a su equipo.

Blank lined page for notes.



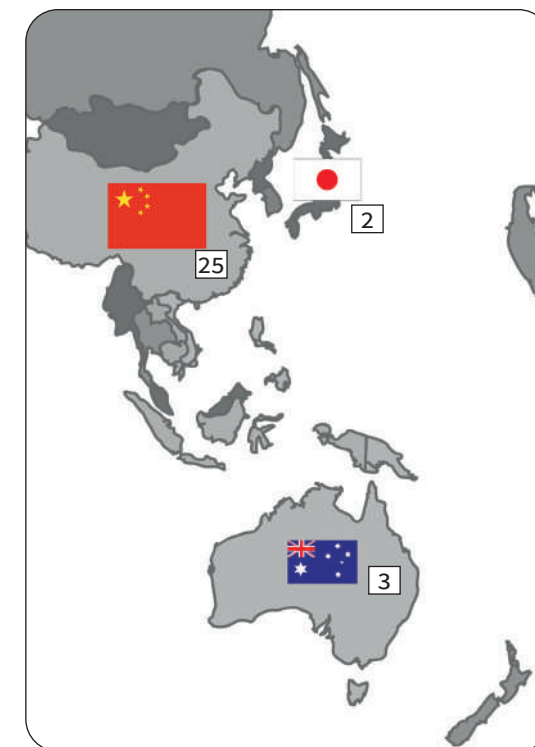



(1) Prairie Agri Sales Ltd.
W. Heidebrecht
P.O Box 216
Road 6W , 26028
Lowe Farm, MB R0G 1E0
Tel.: 001-204-746-6994
Fax: 001-204-515-4064
E-Mail: wheidebrecht@prairiegrisales.ca



(6) IP Innovations et Paysage
ZI de Saint Nizier
F - 42190 Charlieu
Tel.: 0033 / 477 605454
Fax: 0033 / 477 606846
E-Mail: info@innovex-gmbh.de



(11) Oy J-Trading Ab
Kuriiritie 15
01510 Vantaa
Tel.: 00358 / 207458600
Fax: 00358 / 207458651
E-Mail: info@j-trading.fi



(16) EZ Agrar e. Gen
Salzburger Straße 38
4020 Linz
Tel.: 0043 / 732 347266
Fax: 0043 / 732 347260
E-Mail: office@ezagr.ar.at



(21) Mühthing GmbH & Co. KG Soest
Am Silberg 23
59494 Soest
Tel.: 02921 / 9651 -0
Fax: 02921 / 73080
E-Mail: et-soest@muething.com



(2) Agri Direct Co. Ltd.
Higashimemuro, Memuro-cho,
Kasai-gun
18-7 Kita 1-sen
Hokkaido 082-0004
Tel.: 0081 / 155612777
Fax: 0081 / 155612755
E-Mail: info@agridirect.jp



(7) GTJ
Peter Janssen
Way Broek 5
6041PJ Roermond
Tel.: 0031 / 615370411
E-Mail: p.janssen@gjtjtrading.nl



(12) Brøns Group
Hovedvejen 20
6780 Skærbæk
Tel.: 0045 / 74753112
E-Mail: brons@bronsgroup.com



(17) Güttler Mezőgazdasági
Gépgyárto és Szolgá Kft.
Külterület 022/ 35
6800 Hódmezővásárhely
Tel.: 0036 / 62 533690
Fax: 0036 / 62 533691
E-Mail: orsolay.torok@guttler.hu



(22) Mühthing GmbH & Co. KG Uffenheim
Am Brunnlein 2
97215 Uffenheim
Tel.: 09842 / 9866 - 0
Fax: 09842 / 9866 - 67
E-Mail: et-uff@muething.com



(3) Southern Cross Mowers PTY Ltd.
Marcus Cornish
1/29 Mustang Drive, PO Box 454
Rutherford NSW Australia 2320
Tel.: 0061 / 240440313
Fax: 0061 / 249321088
E-Mail: mcornish@sxm.com.au



(9) Van Dyke Marcel Belgium
Provinciebaan 71 - 2235 Houtvenne
Tel.: 0032 / 16699156
E-Mail: info@vandyck.be
GÖWEIL BNL PGmbH - Mirfeld
Zur Schmiede 23 - 4770 Amel
E-Mail: office@goeweil.be



(13) Konekesko Eesti AS
Pildiküla Rae vald
Porguvälja tee 3a
75308 Harjumaa MK
Tel.: 00372 / 6059100
Fax: 00372 / 6059101
E-Mail: kristjan.nelis@kesko.ee



(18) Topagri S.r.o.
Kostalkova 1527
26601 Beroun
Tel.: 00420 / 311 636766
Fax: 00420 / 311621822
E-Mail: topagri@topagri.cz



(23) EZ Landmaschinen AG
Bützbergstrasse 70
4912 Aarwangen
Tel.: 0041 / 62 9226801
Fax: 0041 / 62 9230369
E-Mail: info@ezlandmaschinen.ch



(4) Simon Richard Ltd.
Crown Tailrig
Simon Richardt
Bonchester Bridge
Hawick TD9 8RA
Tel.: 0044 / 1450860774
Fax: 0044 / 1450860772
E-Mail: mail@simon-richard.co.uk



(9) Felten Freres et Fils Sarl
Zone Artisanale
9775 Weicherdange
Tel.: 00352 921612
Fax: 00352 920530
E-Mail: info@felten.lu



(14) SIA Konekesko Latvija
Tiraines 15
1058 Riga
Tel.: 00371 / 67064300
Fax: 00371 / 67064301
E-Mail: aivars.metla-rozents@kesko.lv



(19) Ematech s.r.o
Piestanska 3/3
95605 Radosina
Tel.: 00421 / 385398119
Fax: 00421 / 385398216
E-Mail: ematech@ematech.sk



(24) G.I.Antonakis A.E.
3 xlm Thiva-Mouriki
32200 Thiva
Tel.: 0030 / 2262 025915
Fax: 0030 / 2262 025914
E-Mail: gianton@otenet.gr



(5) Delgado Delgado e Hijos, S.A.
C / Sevilla , 23
34004 Palencia
Tel.: 0034 / 979728450
Fax: 0034 / 979710390
E-Mail: recambios@deltacinco.es



(10) ForSentralen AS
Einar M. Bardal/ Carl M. Bardal
Bardalsvegen 100
7724 Steinkjer
Tel.: 0047 / 7414-7600
Fax: 0047 / 7414-9399
E-Mail: forsentralen@online.no



(15) UAB Konekesko
Vilniaus raj.
Moletu g. 13
14262 Didžioji Riese
Tel.: 00370 / 46421752
Fax: 00370 / 46421753
E-Mail: vilnius.sventkauskas@kesko.lt



(20) NHR Agropartners SRL
Judet Ilfov
Calea Bucurestilor 247
075100 Otopeni
Tel.: 0040 / 21 3007906
Fax: 0040 / 213521660
E-Mail: office@vait.ro



(25) Ten Square International Inc. Nanjing
Rm.402 Bldg.2, Zhongqing Plaza NO.96
Caochangmen St. Nanjing, Jiangsu
210013 China
Tel.: 0086 / 25 86210358
Fax: 0086 / 25 86212081
E-Mail: usoffice@tensquareintl.com



Müthing GmbH & Co. KG Soest
Am Silberberg 23
59494 Soest

Tel +49 (0) 2921 96510
Fax +49 (0) 2921 73080
soest@muething.com

Müthing GmbH & Co. KG Uffenheim
Am Brünlein 2
97215 Uffenheim

Tel +49 (0) 9842 98660
Fax +49 (0) 9842 98667
uffenheim@muething.com

WWW.MUETHING.COM