



ERSATZTEILLISTE | Spare parts list

Liste des pièces de rechange | Lista de repuestos

MU-C-F 100 - 160

AB SERIE | as of series | á partir de série | desde de la serie 2015

AUSGABE | edition | version | edición 12.2019

ARTIKELNUMMER | article number | número d'article | número de artículo MU-C-F_ET_15_2019-12

Übertragen Sie hier bitte die Daten Ihres Gerätes und des verwendeten Getriebes.

Enter the details for your implement and the gear box you are using here.

Veuillez inscrire ici les références de votre machine et celles du boîtier.

Introduzca aquí los datos de su equipo y la transmisión utilizada.



*Beispiel Typenschild | Type plate example
Exemple de plaque signalétique | Ejemplo de una placa de características*

Benennung Designation Désignation Designación	Eintrag Entry N° d'enregistrement Registro
Modell Model Modèle Modelo	MU-C-F 100 - 160 <input type="checkbox"/> 100 <input type="checkbox"/> 120 <input type="checkbox"/> 140 <input type="checkbox"/> 160
Seriennummer Serial number N° de série Número de serie	
Baujahr Year of manufacture Année de construction Año de construcción	
Getriebetyp Gearbox type Type de Système d'entraînement Tipo de transmisión	
Anbaubock Headstock Attelage Soporte adosado	
Händler Dealer Distributeur Concesionario	
Inbetriebnahme am Commissioning date Date de mise en service Fecha de puesta en servicio	

Bei bitte deutlich ankreuzen !

Where there are checkboxes , please check these clearly!

Veuillez cocher les cases lisiblement!

Por favor, marque con una cruz en la casilla .



Blank lined page for notes.



Einleitung Introduction Introduction Introducción 	6
Gerätebeschreibung Device description Description de l'appareil Description del dispositivo 	7
Grundausführung Basic model Modèle de base Modelo básico 	
Gehäuse Housing Caisson Caja 	8
Antrieb & Getriebe Drive and gear box Transmission et Système d'entraînement Accionamiento e Cambio 	12
Übersetzung Getriebe Gear box translation Système d'entraînement multiplication Cambio la traducción 	16
Schäkelrotor Shackle rotor Rotor á manillas Grillete rotor 	18
Stützwalze Support roller Rouleau d'appui Cilindro de apoyo 	22
Dreipunktbock 3-point trestle Support d'attelage trois point Soporte de tres apoyos 	26
Getriebe MA 20 gear box on the MA 20 Système d'entraînement MA 20 Cambio MA 20 	30
Sonderzubehör Optional accessory Accessoires optionnels Componentes especiales 	
Gelenkwelle - GE2101-SFT-ET Cardan shaft - GE2101-SFT-ET Cardan - GE2101-SFT-ET Árbol de transmisión - GE2101-SFT-ET 	34
Gelenkwelle - GE2102-SFT-ET Cardan shaft - GE2102-SFT-ET Cardan - GE2102-SFT-ET Árbol de transmisión - GE2102-SFT-ET 	36
Gelenkwelle - GE2103-SFT-ET ISEKI Cardan shaft - GE2103-SFT-ET ISEKI Cardan - GE2103-SFT-ET ISEKI Árbol de transmisión - GE2103-SFT-ET ISEKI 	38
Gelenkwelle - GE2104-SFT-ET KUBOTA Cardan shaft - GE2104-SFT-ET KUBOTA Cardan - GE2104-SFT-ET KUBOTA Árbol de transmisión - GE2104-SFT-ET KUBOTA 	40
Stützrad Support wheel Roue d'appui Rueda de soporte 	42
Unterlenkeraufnahme lower link receiver Logement du bras inférieur Alojamiento del brazo inferior 	46
Gerätedreieck KAT 0 Implement triangle KAT 0 Triangle d'attelage KAT 0 Triángulo del dispositivo KAT 0 	48
Kurzhäckselleiste Short chopping bar Lame hache-paille courte Listón de corte de paja corto 	50
Verschleißeinlage Wear insert Blindage Junta de desgaste 	52
Hydraulische Druckentlastung MU-SOFA Hydraulic pressure relief MU-SOFA Délestage hydraulique MU-SOFA Descarga de presión hidráulica MU-SOFA 	54
Kontakte Contacts Contacts Contactos 	
National Nactional National Nacional 	59
International Internactional Internationale Internationalmente 	60

20 horizontal dotted lines for writing.



SEHR GEEHRTER KUNDE,

auf den folgenden Seiten finden Sie eine vollständige Übersicht aller Bauteile Ihres Müthing Mulchgerätes MU-C-F 100 - 160. Anhand dieser Unterlage bitten wir Sie benötigte Ersatzteile genau zu identifizieren und mit den nachfolgenden Angaben zu bestellen. Benötigen Sie Hilfe oder weitere Informationen kontaktieren Sie uns.

Vielen Dank - Ihr Müthing-Team

CHER CLIENT,

Vous trouverez sur les pages suivantes une description complète des composants de votre broyeur Müthing MU-C-F 100 - 160. Nous vous invitons à identifier exactement les pièces de rechange requises à l'appui de ce document et de les commander en indiquant le n° de référence de pièces de rechange. N'hésitez pas à nous contacter si vous avez besoin d'aide ou d'informations complémentaires.

Merci beaucoup – Votre équipe Müthing

DEAR CUSTOMER,

The following pages offer a complete overview of the components in your Müthing MU-C-F 100 - 160 mulcher. We are providing you with this document so that you can identify exactly the spare parts you require and order them using the spare part numbers listed. Should you need any assistance or further information, please contact us.

Kind regards - Your Müthing team

ESTIMADO CLIENTE,

En las siguientes páginas ponemos a su disposición una relación completa de los componentes de su trituradora MU-C-F 100 - 160 de Müthing. Le rogamos que con ayuda de este listado identifique las piezas de repuesto necesarias y las encargue con su correspondiente número de repuesto. No dude en ponerse en contacto con nosotros para solicitar ayuda o información ampliada.

Muchas gracias - Su equipo Müthing



Beachten Sie immer die Sicherheitshinweise der Betriebsanleitung !

Always follow the safety instructions in the operating manual.

Veuillez toujours tenir compte des consignes de sécurité figurant dans le manuel d'utilisation !

Observe siempre las indicaciones de seguridad de las instrucciones de servicio !

DIE HAUPTBAUGRUPPEN SIND:

1. Mulchergehäuse mit Schutzlamellen, hinterem Gummischutz und Gleitkufen
2. Rotor mit Lagerung, Werkzeugen und Werkzeughaltern
3. Stützwalze (Stützräder) mit Lagerung
4. Keilriemenantrieb mit Keilriemenschutzhaube
5. Getriebe
6. Gelenkwelle (Explosionszeichnung)
7. Sonderzubehör

THE MAIN COMPONENTS ARE:

1. Mulcher housing with protective strips, rear rubber protector and skids
2. Rotor with mount, tools and tool holders
3. Support roller (support wheels) with mount
4. V-belt drive with V-belt guard
5. Gear box
6. PTO shaft (exploded view)
7. Optional accessories



LES GROUPES PRINCIPAUX SONT:

1. Carter du broyeur avec lamelles de protection, protection en caoutchouc à l'arrière et patins de glissement
2. Rotor équilibré avec outils et supports d'outils
3. Rouleau d'appui (roues supports) avec suspension
4. Transmission par courroie trapézoïdale avec capot de protection
5. Système d'entraînement
6. Arbre de transmission (vue éclatée)
7. Accessoires spécifiques

LOS GRUPOS CONSTRUCTIVOS PRINCIPALES SON:

1. Carcasa de la trituradora con placas de protección, protección trasera de goma y patines
2. Rotor con cojinete, herramientas y portaherramientas
3. Cilindro de apoyo (ruedas de apoyo) con cojinete
4. Accionamiento por correa trapezoidal con cubierta protectora de la correa
5. Transmisión
6. Árbol de transmisión (plano explosionado)
7. Accesorio especial

| Hauptbaugruppe Schlegelmulcher Baureihe MU-C-F 100 - 160
| Main assembly of the MU-C-F 100 - 160 flail mulcher
| Groupe principal Broyeur à marteaux série MU-C-F 100 - 160
| Grupo constructivo desbrozadora serie MU-C-F 100 - 160

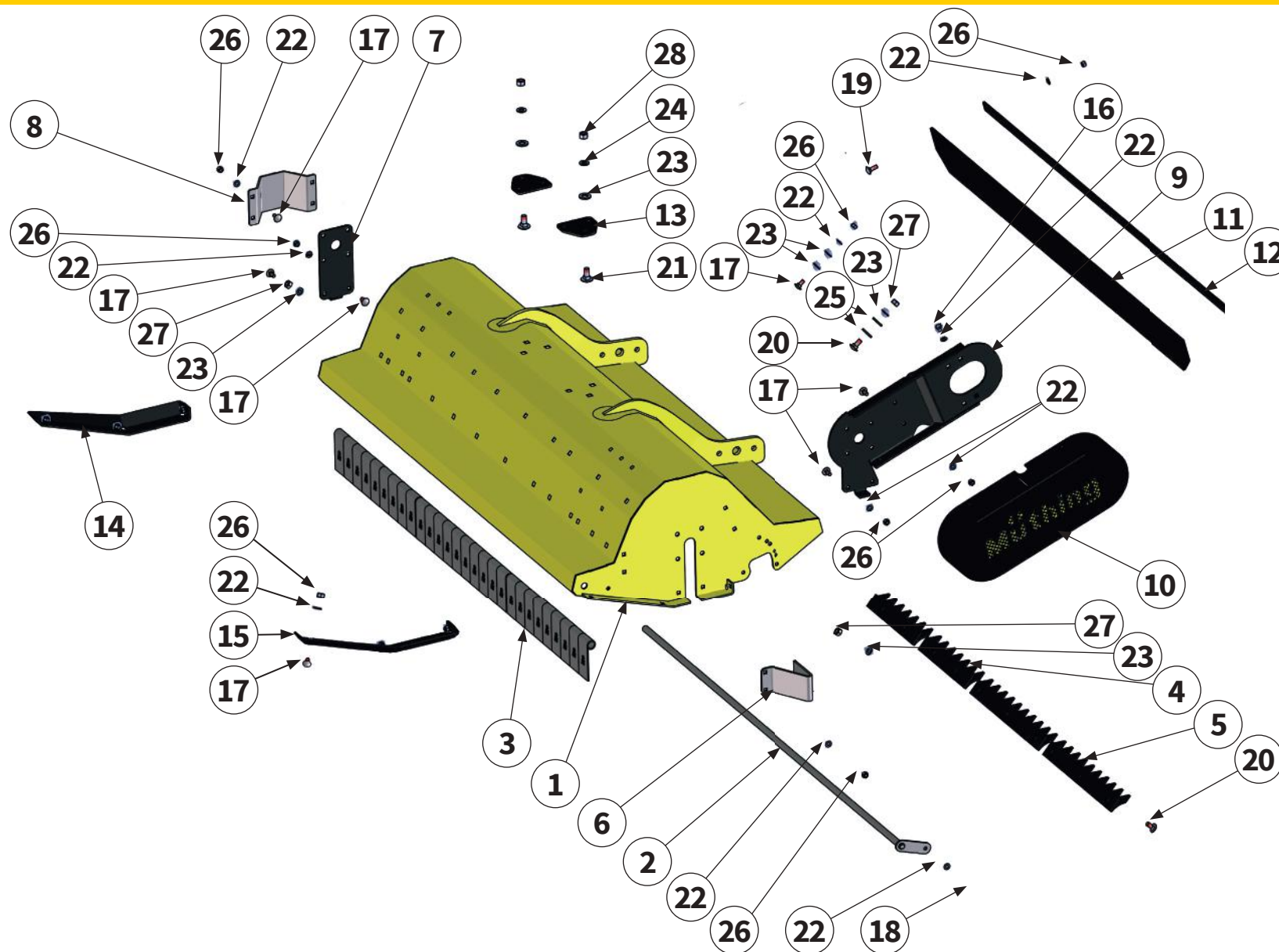

Pos.-Nr. No. Número	Ersatzteilnummer Manufacturer part number Numéro de pièce du fabricant Número de pieza del fabricante				DE Bezeichnung	EN Designation	FR Désignation	ES Designación
	Anzahl quantity quantité número							
	MU-C 100	MU-C 120	MU-C 140	MU-C 160				
1	00015638 1	00015351 1	00015639 1	00015642 1	Gehäuse	housing	Caisson	Caja
2	00001295 1	00001124 1	00001374 1	00001798 1	Pendelwelle	swing shaft	Arbre oscillant	Eje del péndulo
3	MU0501131				Pendelklappen	flap with swing protection	Volvet de protection	Tapa protectora del péndulo
	20	24	28	32				
4	00005472				Gegenschneide 300	chopping bars	Lame hache-paille courte	Listón de corte de paja corto
	2	-	2	-				
5	00005474				Gegenschneide 400	chopping bars	Lame hache-paille courte	Listón de corte de paja corto
	1	3	2	4				
6	MU0216011				Abweiser	deflector	Défecteur	Deflector
	1	1	1	1				
7	MU0501171				Verschlußblech	sealing sheet	Tôle de fermeture	Chapa de cierre
	1	1	1	1				
8	00001129				Lagerabdeckung	bearing cover	Couvercle de palier	Tapa de cojinete
	1	1	1	1				
9	MU0510031				Halteblech	retaining plate	Tôle de maintien	Chapa soporte
	1	1	1	1				
10	MU0510051				Schutzabdeckung	protective cover	Recouvrement de protection	Cubierta protectora
	1	1	1	1				
11	00005494 1	00003530 1	00003524 1	00003519 1	Schutzgummi	guard	Protection	Protección
12	00005493 1	00003529 1	00003523 1	00003518 1	Klemmleiste	support plate	Tôle de support	Chapa de retención
13	00004053				Distanzblech	spacer plate	Tôle d'écartement	Chapa distanciadora
	2	2	2	2				
14	00010882				Verschleißkufe links	wear runner left	Patin d'usure gauche	Cuchilla de desgaste izquierda
	1	1	1	1				

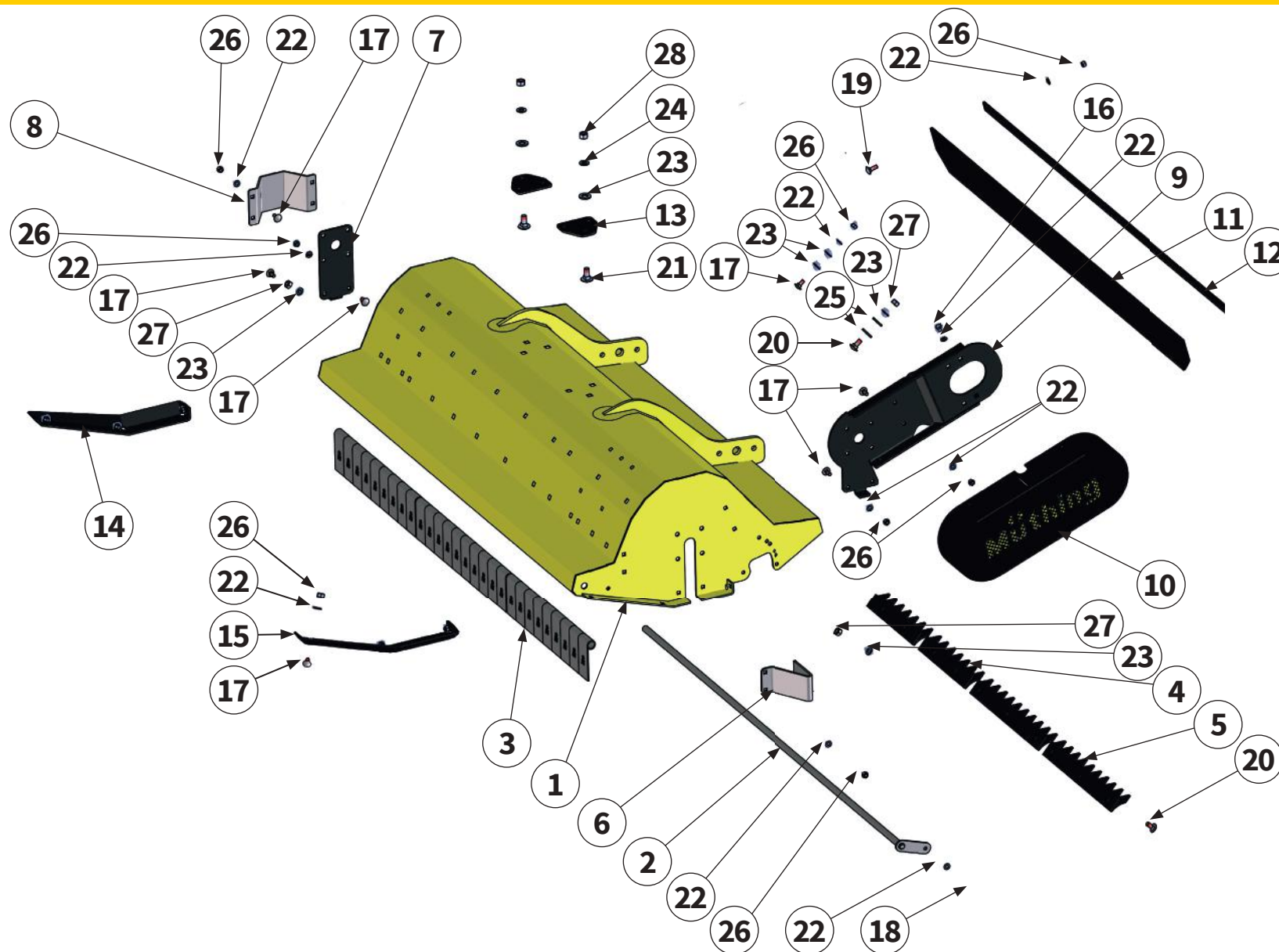

Pos.-Nr. No. Numéro Número	Ersatzteilnummer Manufacturer part number Numéro de pièce du fabricant Número de pieza del fabricante				DE Bezeichnung	EN Designation	FR Désignation	ES Designación
	Anzahl quantity quantité número							
	MU-C 100	MU-C 120	MU-C 140	MU-C 160				
15	00010883				Verschleißkufe rechts	wear runner right	Patin d'usure droite	Cuchilla de desgaste derecha
	1	1	1	1				
16	MU980127				Schraube	bolt	Vis	Tornillo
	4	4	4	4				
17	MU980107				Schraube	bolt	Vis	Tornillo
	21	21	21	21				
18	MU980109				Schraube	bolt	Vis	Tornillo
	1	1	1	1				
19	MU0099988				Schraube	bolt	Vis	Tornillo
	9	9	11	15				
20	00000903				Schraube	bolt	Vis	Tornillo
	9	11	12	14				
21	MU980310				Schraube	bolt	Vis	Tornillo
	6	6	6	6				
22	MU0099999				Scheibe	washer	Disque	Arandela
	36	36	38	40				
23	MU980202				Scheibe	washer	Disque	Arandela
	15	17	18	20				
24	MU980302				Scheibe	washer	Disque	Arandela
	6	6	6	6				
25	MU980402				Scheibe	washer	Disque	Arandela
	10	10	10	10				
26	MU0099961				Mutter	nut	Écrou	Tuerca
	31	31	31	33				
27	MU0099960				Mutter	nut	Écrou	Tuerca
	9	11	12	14				
28	MU980301				Mutter	nut	Écrou	Tuerca
	6	6	6	6				

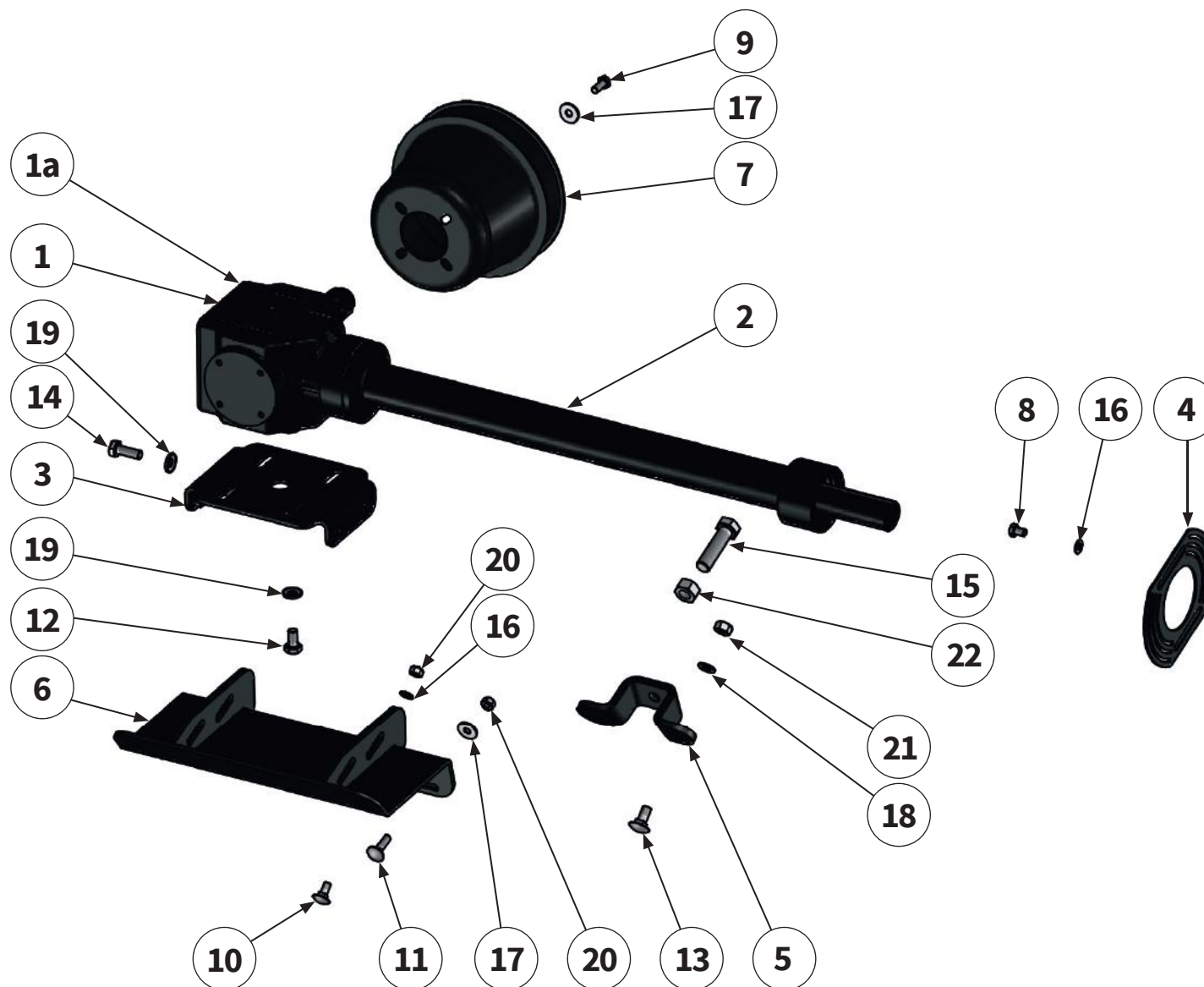

Eine detaillierte Explosionskizze des Getriebes finden Sie auf den folgenden Seiten.

A detailed exploded view of the gear box can be found on the following pages.

Vous trouverez un schéma éclaté détaillé du boîtier sur les pages suivantes.

En las siguientes páginas también se incluye un diagrama de vista explotada de la transmisión.



Pos.-Nr. No. Numéro Número	Ersatzteilnummer Manufacturer part number Numéro de pièce du fabricant Número de pieza del fabricante				DE Bezeichnung	EN Designation	FR Désignation	ES Designación
	Anzahl quantity quantité número							
	MU-C 100	MU-C 120	MU-C 140	MU-C 160				
1	M20T1.9LINKS-BRM				Getriebe links	gear box left	Système d'entraînement gauche	Cambio izquierda
	1	1	1	1				
Getriebe-Eingangsdrehzahl Input speed Vitesse d`entree Velocidad entrada 1000 / min -1 (1:1,93) links left à gauche a la izquierda								
1a	M20T1.9RECHTS-BRM				Getriebe rechts	gear box right	Système d'entraînement droite	Cambio derecha
	1	1	1	1				
Getriebe-Eingangsdrehzahl Input speed Vitesse d`entree Velocidad entrada 1000 / min -1 (1:1,93) rechts right à droite a la derecha								
2	MU2000530-BRM	MU2000630-BRM	MU2000730-BRM	MU2000830-BRM	Getriebever- längerung	shaft extension	Arbre de rollonge	Prolongación
	1	1	1	1				
3	00015590				Verstellblech	adjusting plate	Plaque de réglage	Placa de ajuste
	1	1	1	1				
4	00003532				Abdeckung	cover	Recouvrement	Cubierta
	1	1	1	1				
5	00009656				Aufnahme	holder	Support	Alojamiento
	1	1	1	1				
6	00009646				Getriebehalter	gear box holder	Support de transmission	Soporte del cambio
	1	1	1	1				
7	MU1510160				Schutztopf	protective pot	Barillet de protection	Tapa de protección
	1	1	1	1				
8	MU980159				Schraube	bolt	Vis	Tornillo
	2	2	2	2				
9	MU980115				Schraube	bolt	Vis	Tornillo
	4	4	4	4				
10	MU980107				Schraube	bolt	Vis	Tornillo
	3	3	3	3				

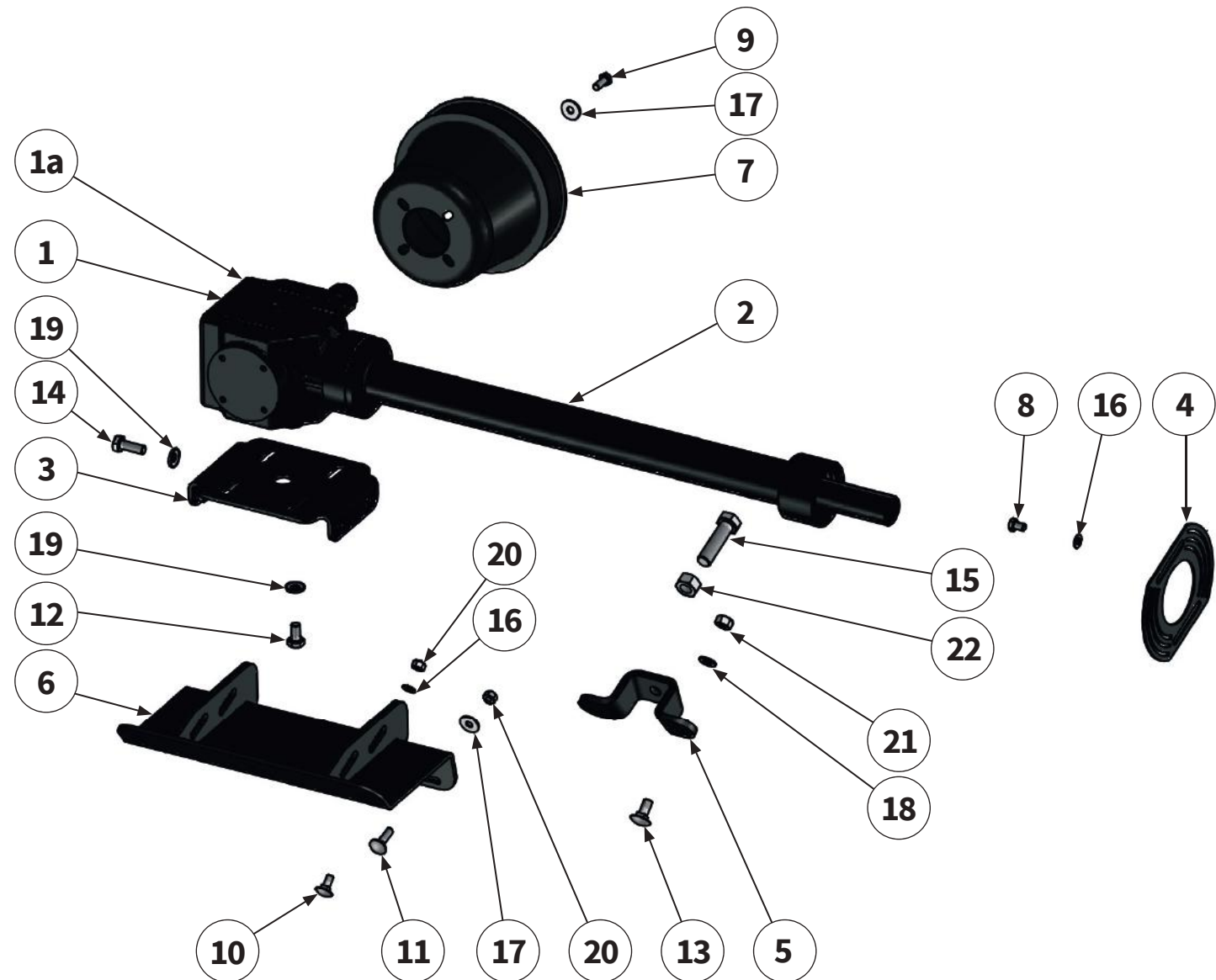

Eine detaillierte Explosionskizze des Getriebes finden Sie auf den folgenden Seiten.

A detailed exploded view of the gear box can be found on the following pages.

Vous trouverez un schéma éclaté détaillé du boîtier sur les pages suivantes.

En las siguientes páginas también se incluye un diagrama de vista explotada de la transmisión.



Pos.-Nr. No. Numéro Número	Ersatzteilnummer Manufacturer part number Numéro de pièce du fabricant Número de pieza del fabricante				DE Bezeichnung	EN Designation	FR Désignation	ES Designación
	Anzahl quantity quantité número							
	MU-C 100	MU-C 120	MU-C 140	MU-C 160				
11	MU0099987				Schraube	bolt	Vis	Tornillo
	3	3	3	3				
12	MU0099970				Schraube	bolt	Vis	Tornillo
	4	4	4	4				
13	00000903				Schraube	bolt	Vis	Tornillo
	2	2	2	2				
14	MU980205				Schraube	bolt	Vis	Tornillo
	4	4	4	4				
15	MU981002				Schraube	bolt	Vis	Tornillo
	1	1	1	1				
16	MU0099999				Scheibe	washer	Disque	Arandela
	5	5	5	5				
17	MU0099951				Scheibe	washer	Disque	Arandela
	7	7	7	7				
18	MU980202				Scheibe	washer	Disque	Arandela
	2	2	2	2				
19	MUNSKL10				Scheibe	washer	Disque	Arandela
	8	8	8	8				
20	MU0099961				Mutter	nut	Écrou	Tuerca
	6	6	6	6				
21	MU0099960				Mutter	nut	Écrou	Tuerca
	2	2	2	2				
22	MU980400				Mutter	nut	Écrou	Tuerca
	1	1	1	1				



Getriebe-Eingangsdrehzahl | Input speed | Vitesse d`entree | Velocidad entrada |

1000 min -1

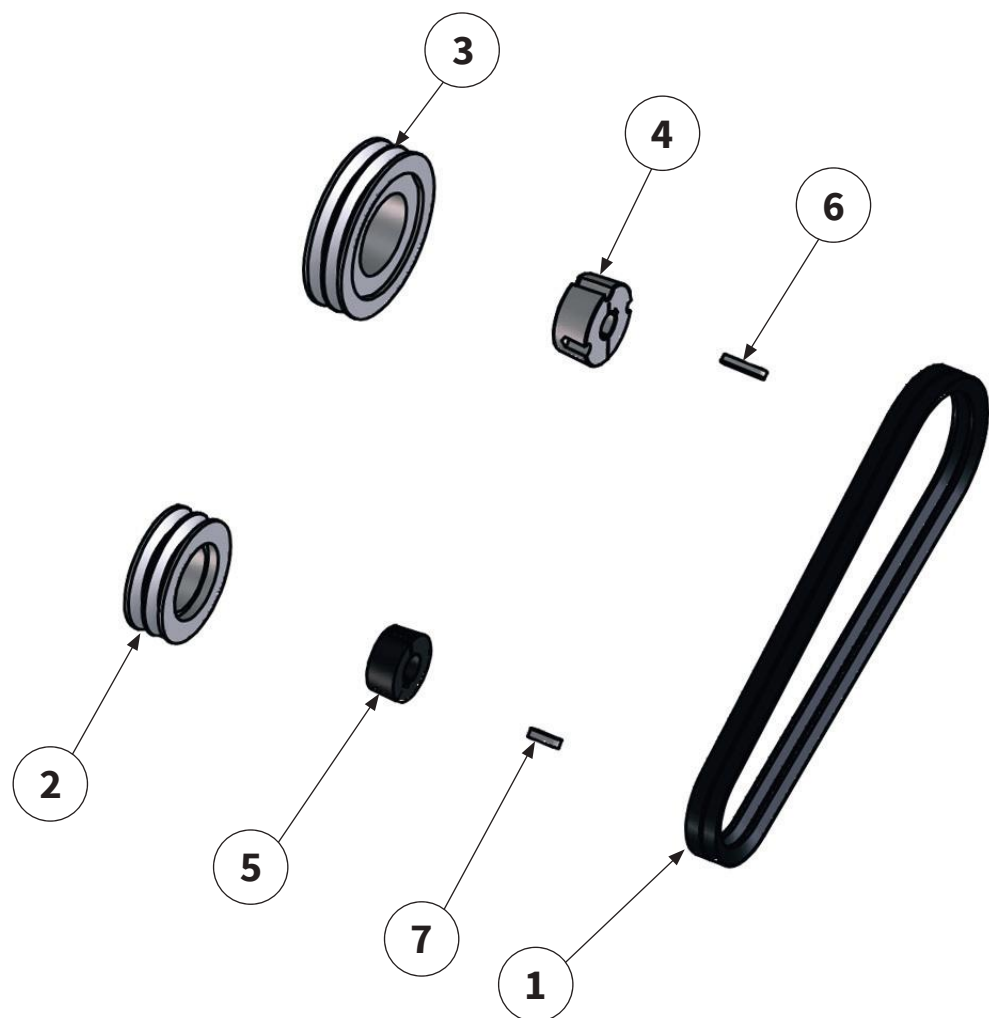

Getriebe-Eingangsdrehzahl | Input speed | Vitesse d`entree | Velocidad entrada |

2000 min -1

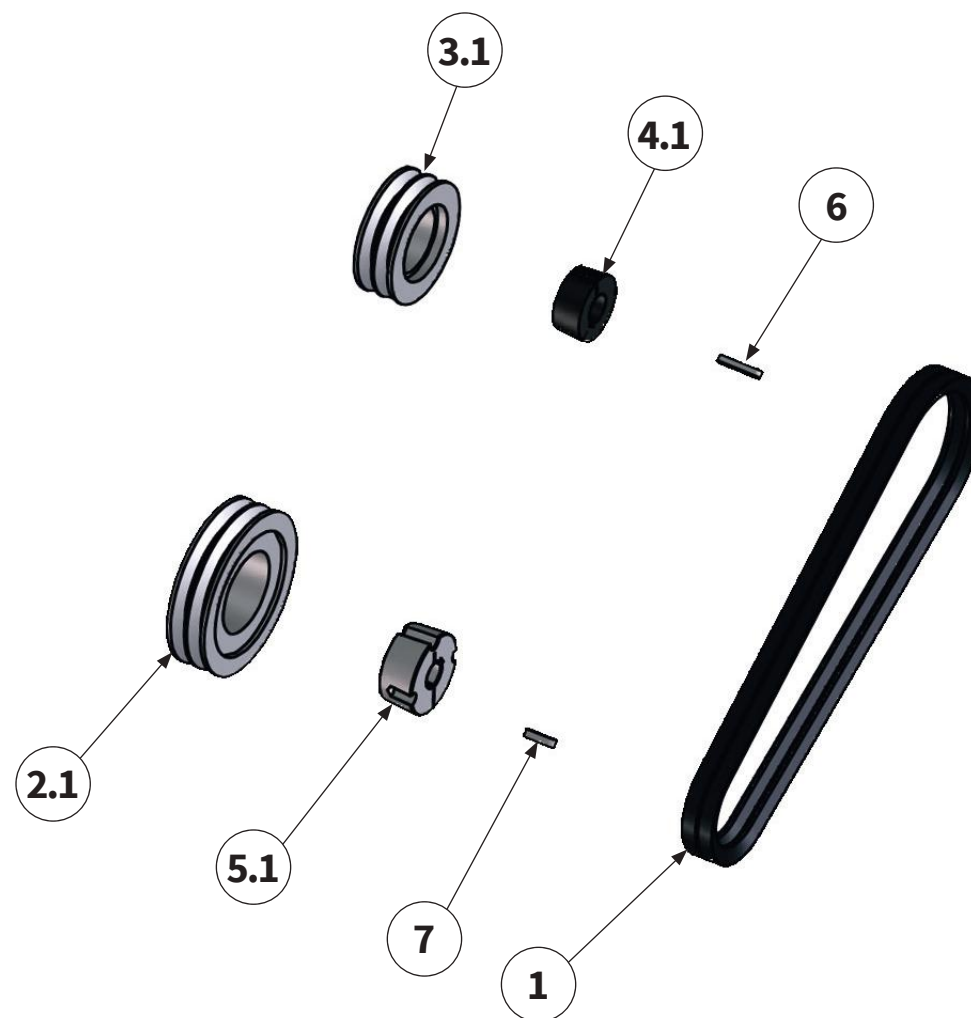

Pos.-Nr. No. Número	Ersatzteilnummer Manufacturer part number Numéro de pièce du fabricant Número de pieza del fabricante				DE Bezeichnung	EN Designation	FR Désignation	ES Designación
	Anzahl quantity quantité número							
	MU-C 100	MU-C 120	MU-C 140	MU-C 160				
1	MU0501995				Keilriemen	V-belt	Courroie trapézoïdale	Correa trapezoidal
	2	2	2	2				
2	00001087				Riemenscheibe	belt pulley	Poulie	Polea
	1	1	1	1				
2.1	MU0501111				Riemenscheibe	belt pulley	Poulie	Polea
	1	1	1	1				
3	MU0501111				Riemenscheibe	belt pulley	Poulie	Polea
	1	1	1	1				
3.1	00001087				Riemenscheibe	belt pulley	Poulie	Polea
	1	1	1	1				
4	00005570				Spannbuchse	clamping bush	Douille de serrage	Manguito de sujeción
	1	1	1	1				
4.1	00001093				Spannbuchse	clamping bush	Douille de serrage	Manguito de sujeción
	1	1	1	1				
5	MU981805				Spannbuchse	clamping bush	Douille de serrage	Manguito de sujeción
	1	1	1	1				
5.1	00011451				Spannbuchse	clamping bush	Douille de serrage	Manguito de sujeción
	1	1	1	1				
6	00008108				Paßfeder	parallel key	Clavette	Chaveta de ajuste
	1	1	1	1				
7	00001085				Paßfeder	parallel key	Clavette	Chaveta de ajuste
	1	1	1	1				



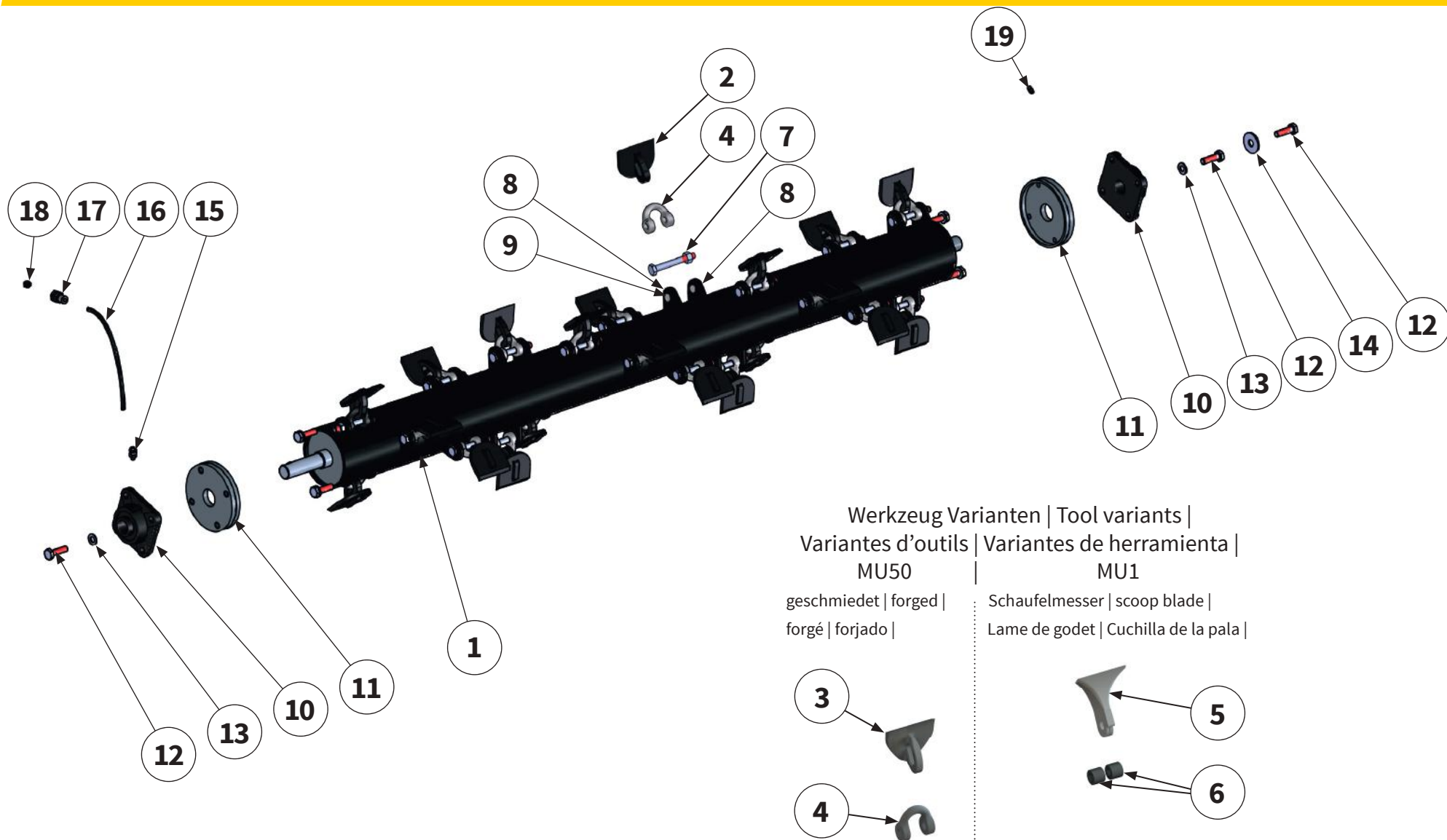

Werkzeug Varianten | Tool variants |
 Variantes d'outils | Variantes de herramienta |

MU50
 geschmiedet | forged |
 forgé | forjado |

MU1
 Schaufelmesser | scoop blade |
 Lame de godet | Cuchilla de la pala |

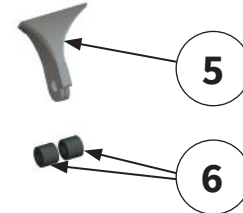
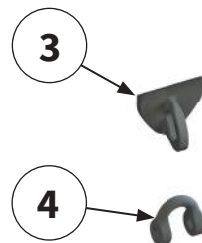

Pos.-Nr. No. Número	Ersatzteilnummer Manufacturer part number Numéro de pièce du fabricant Número de pieza del fabricante				DE Bezeichnung	EN Designation	FR Désignation	ES Designación
	Anzahl quantity quantité número							
	MU-C 100	MU-C 120	MU-C 140	MU-C 160				
1	MU5040021 1	MU5040031 1	MU5040041 1	00010955 1	Rotor inkl. Werkzeug	rotor with tools	Rotor avec outils	Rotor con herram
2	16	20	24	28	Schäkelmesser	shackle flail	Lame de manille	Chuchilla del grillete
3	16	20	24	28	Schäkelmesser	shackle flail	Lame de manille	Chuchilla del grillete
4	16	20	24	28	Schäkel	shackle	Manille	Grillete
5	16	20	24	28	Schaufelmesser	scoop blade	Lame de godet	Cuchilla de la pala
6	32	40	48	56	Buchse	bush	Douille	Casquillo
7	16	20	24	28	Schraube mit Mutter	bolt with nut	Vis avec Écrou	Tornillo con Tuerca
8	32	40	48	56	Werkzeughalter	tool holders	Porte-outils	portaherramientas
9	16	20	24	28	Verdrehsicherung	anti-twist protec- tion	Sécurité anti-tor- sion	Seguro contra giro
10	2	2	2	2	Rotorlager	rotor holder	Support de Rotor	Soporte del Rotor
11	2	2	2	2	Wickelschutz	anti-wrapping device	Protection contre l'enroulement	Protección enrollable
12	9	9	9	9	Schraube	bolt	Vis	Tornillo
13	8	8	8	8	Scheibe	washer	Disque	Arandela

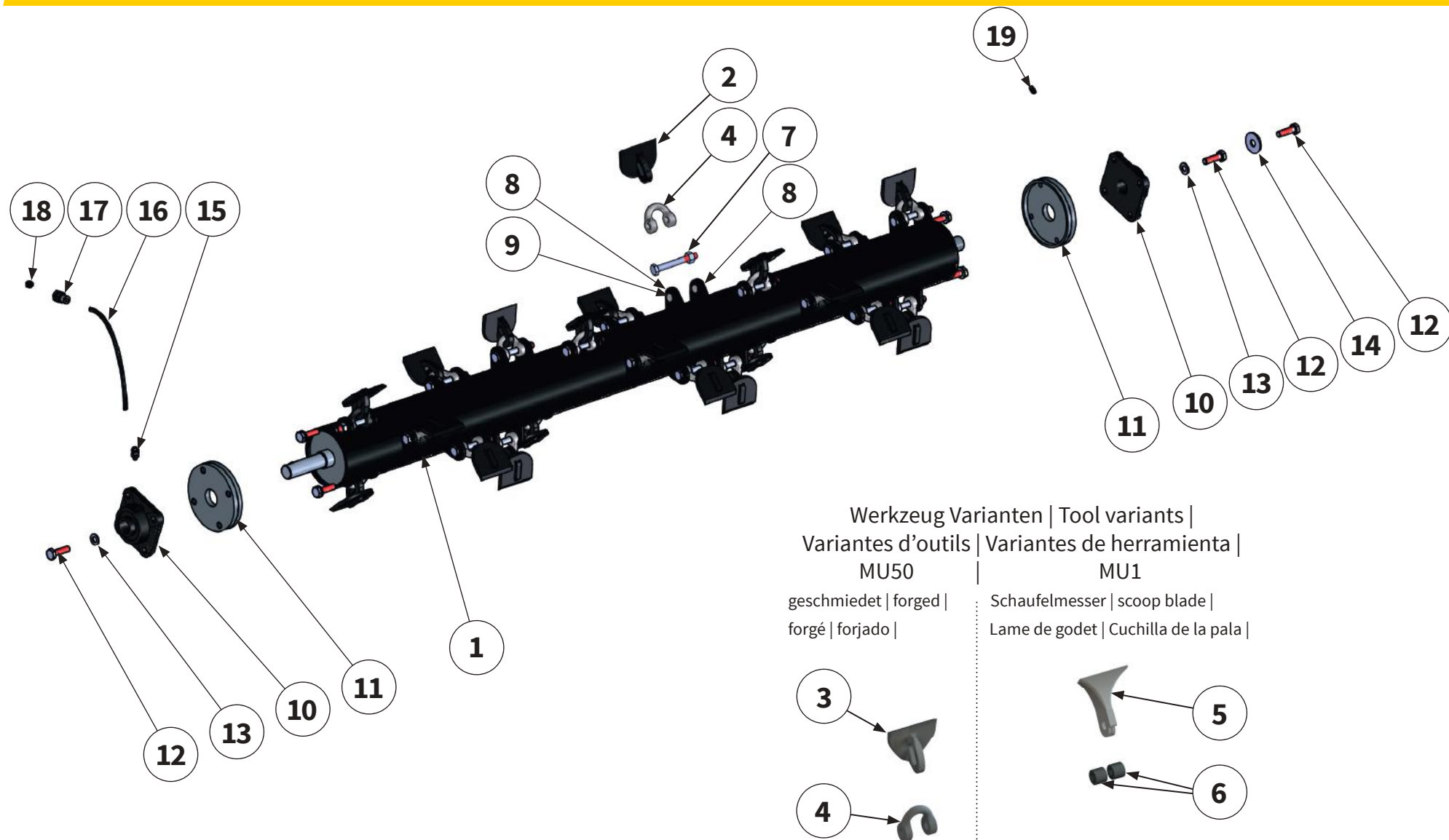

Werkzeug Varianten | Tool variants |
 Variantes d'outils | Variantes de herramienta |
 MU50 | MU1
 geschmiedet | forged | geschmiedet | forged |
 forgé | forjado | forgé | forjado |
 Schaufelmesser | scoop blade | Schaufelmesser | scoop blade |
 Lame de godet | Cuchilla de la pala | Lame de godet | Cuchilla de la pala |

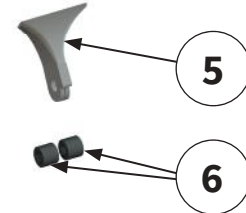
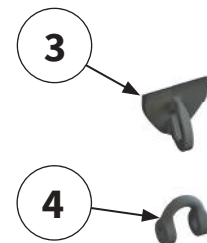

Pos.-Nr. No. Numéro Número	Ersatzteilnummer Manufacturer part number Numéro de pièce du fabricant Número de pieza del fabricante				DE Bezeichnung	EN Designation	FR Désignation	ES Designación
	Anzahl quantity quantité número							
	MU-C 100	MU-C 120	MU-C 140	MU-C 160				
14	MU980203				Scheibe	washer	Disque	Arandela
	1	1	1	1				
15	MULI0001				Verschraubung	Screwed connection	Raccord à vis	Atornillamiento
	1	1	1	1				
16	MULI0005				Schmierleitung	lubrication line	Conduite de graissage	Tubería de engrase
	0,17 m	0,17 m	0,17 m	0,17 m				
17	MULI0003				Verschraubung	Screwed connection	Raccord à vis	Atornillamiento
	1	1	1	1				
18	MULI0004				Schmiernippel	lubricating nipple	Nipple de graissage	Engrasador
	1	1	1	1				
19	DIN71412AH1-M06X1				Schmiernippel	lubricating nipple	Nipple de graissage	Engrasador
	1	1	1	1				



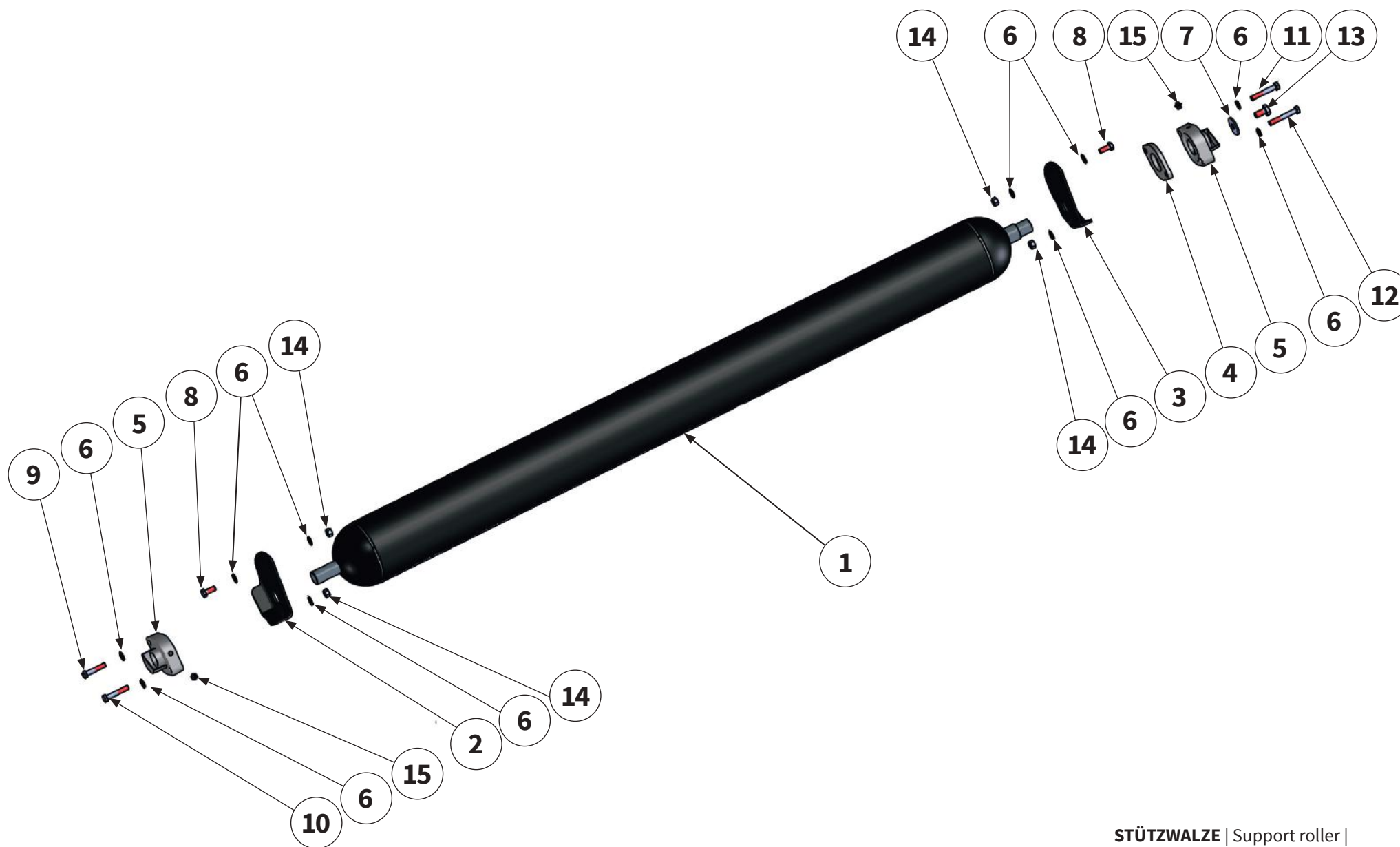

Pos.-Nr. No. Numéro Número	Ersatzteilnummer Manufacturer part number Numéro de pièce du fabricant Número de pieza del fabricante				DE Bezeichnung	EN Designation	FR Désignation	ES Designación
	Anzahl quantity quantité número							
	MU-C 100	MU-C 120	MU-C 140	MU-C 160				
1	MU0110791 1	MU0110792 1	MU0110793 1	MU0110794 1	Stützwalze	support roller	Rouleau d'appui	Cilindro de apoyo
2	00015179 1 1 1 1				Flanschblech links	flange plate left	Plaque de bride gauche	Chapa de bridas izquierda
3	00015180 1 1 1 1				Flanschblech rechts	flange plate right	Plaque de bride droite	Chapa de bridas derecha
4	00001674 1 1 1 1				Platte	plate	Plaque	Placa
5	00001673 2 2 2 2				Flanschlager mit Kappe	flange with cap	Plaque de capuchon	Chapa de cubierta
5.1	KAPPE 2 2 2 2				Abdeckkappe	protective cap	Capuchon de protection	Cubierta protection
6	MU0099999 16 16 16 16				Scheibe	washer	Disque	Arandela
7	MU0099992 1 1 1 1				Scheibe	washer	Disque	Arandela
8	MU980115 4 4 4 4				Schraube	washer	Disque	Arandela
9	MU980128 1 1 1 1				Schraube	bolt	Vis	Tornillo
10	MU980116 1 1 1 1				Schraube	bolt	Vis	Tornillo
11	MU980119 1 1 1 1				Schraube	bolt	Vis	Tornillo
12	MU980118 1 1 1 1				Schraube	bolt	Vis	Tornillo

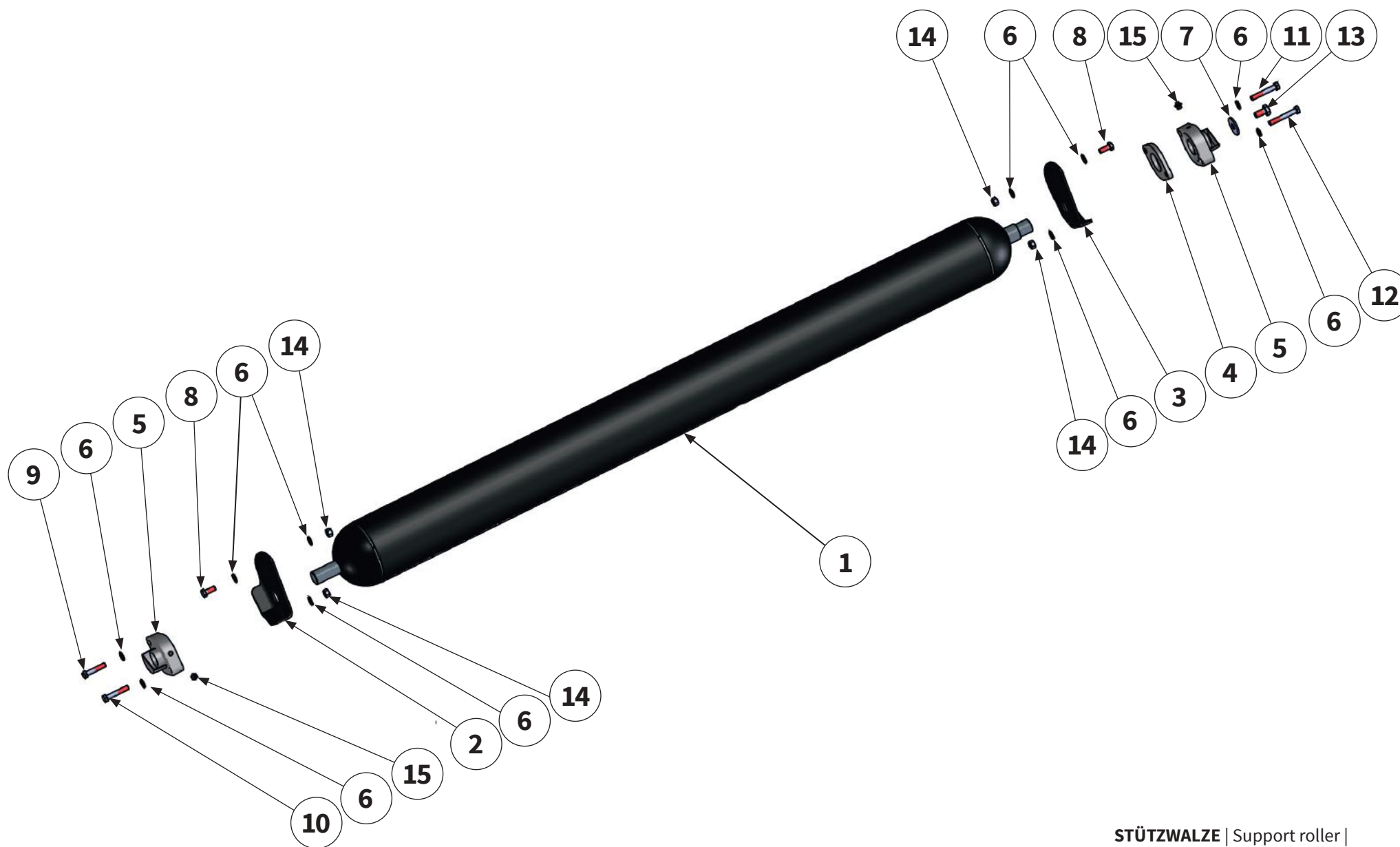

15Pos.- Nr. No. Numéro Número	Ersatzteilnummer Manufacturer part number Numéro de pièce du fabricant Número de pieza del fabricante				DE Bezeichnung	EN Designation	FR Désignation	ES Designación
	Anzahl quantity quantité número							
	MU-C 100	MU-C 120	MU-C 140	MU-C 160				
13	MU0099970				Schraube	bolt	Vis	Tornillo
	1	1	1	1				
14	MU0099961				Mutter	nut	Écrou	Tuerca
	8	8	8	8				
15	DIN71412C-H3-M06X1				Schmiernippel	lubricating nipple	Nipple de graissage	Engrasador
	2	2	2	2				



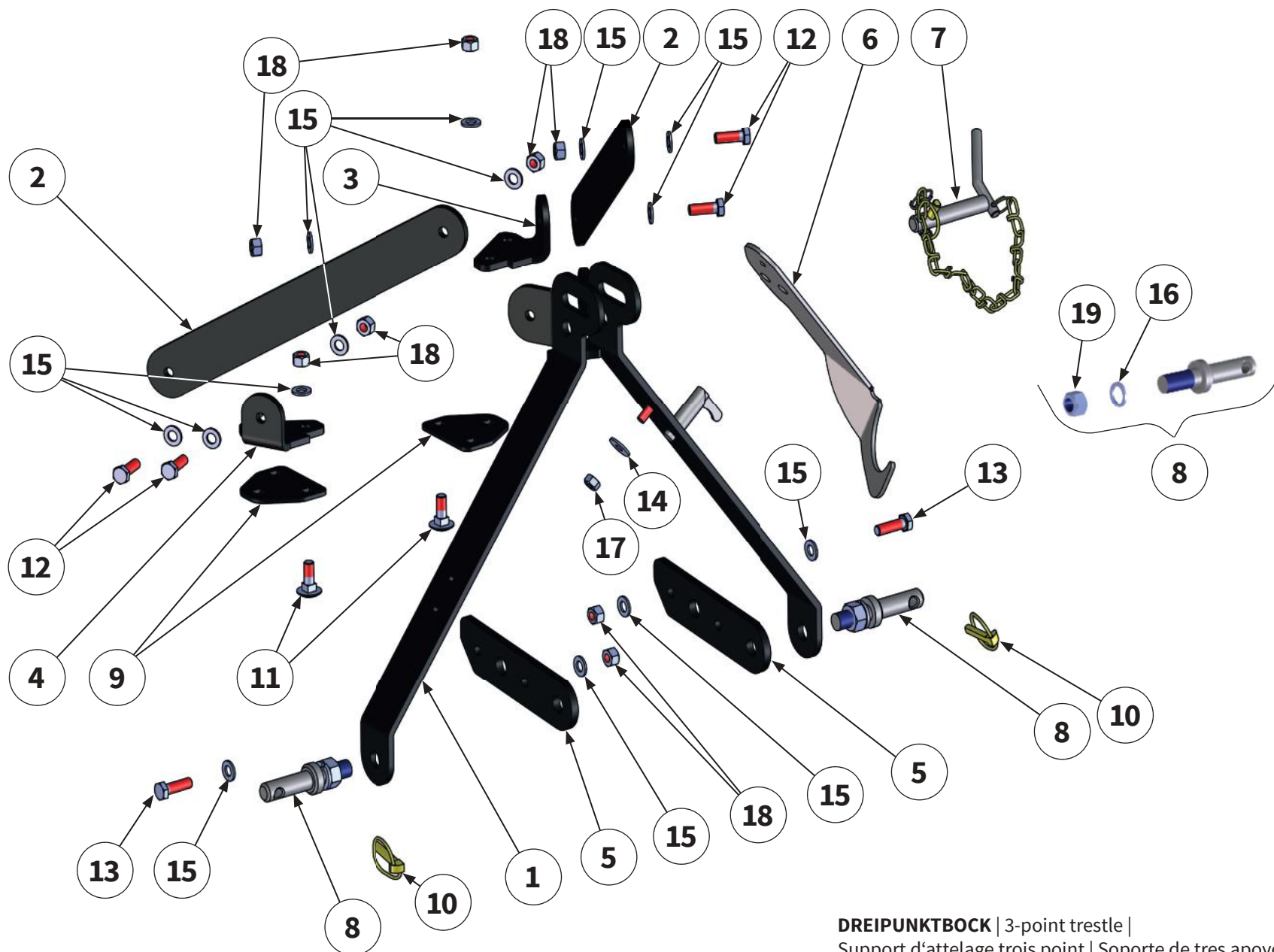

Pos.-Nr. No. Número	Ersatzteilnummer Manufacturer part number Numéro de pièce du fabricant Número de pieza del fabricante				DE Bezeichnung	EN Designation	FR Désignation	ES Designación
	Anzahl quantity quantité número							
	MU-C 100	MU-C 120	MU-C 140	MU-C 160				
1	00011143				Dreipunktbock	3-point trestle	Support d'attelage trois point	Soporte de tres apoyos
	1	1	1	1				
2	00010868				Strebe	strut	Jambe de force	Tirante
	2	2	2	2				
3	MU0503032				Halter links	holder left	Support à gauche	Soporte a la izquierda
	1	1	1	1				
4	MU0503031				Halter rechts	holder right	Support à droite	Soporte a la derecha
	1	1	1	1				
5	MU0503061				Unterlenkeraufnahme	lower link receiver	Logement du bras inférieur	Alojamiento del brazo inferior
	2	2	2	2				
6	00010869				Gelenkwellenhalter	PTO shaft holder	Support d'arbre à cardan	Soporte del árbol articulado
	1	1	1	1				
7	00005545				Bolzen mit Kette	pin with chain	Axe avec Chaîne	Perno con Cadena
	1	1	1	1				
8	MU0501996				Bolzen kpl.	pin complete	Axe complet	Perno completo
	2	2	2	2				
9	00004053				Distanzblech	spacer plate	Tôle d'écartement	Chapa distanciadora
	2	2	2	2				
10	MU0099948				Klappstecker	lynch pin	Esse d'essieu	Pasador abatible
	2	2	2	2				
11	MU980320				Schraube	bolt	Vis	Tornillo
	6	6	6	6				
12	MU980311				Schraube	bolt	Vis	Tornillo
	4	4	4	4				
13	MU980328				Schraube	bolt	Vis	Tornillo
	4	4	4	4				

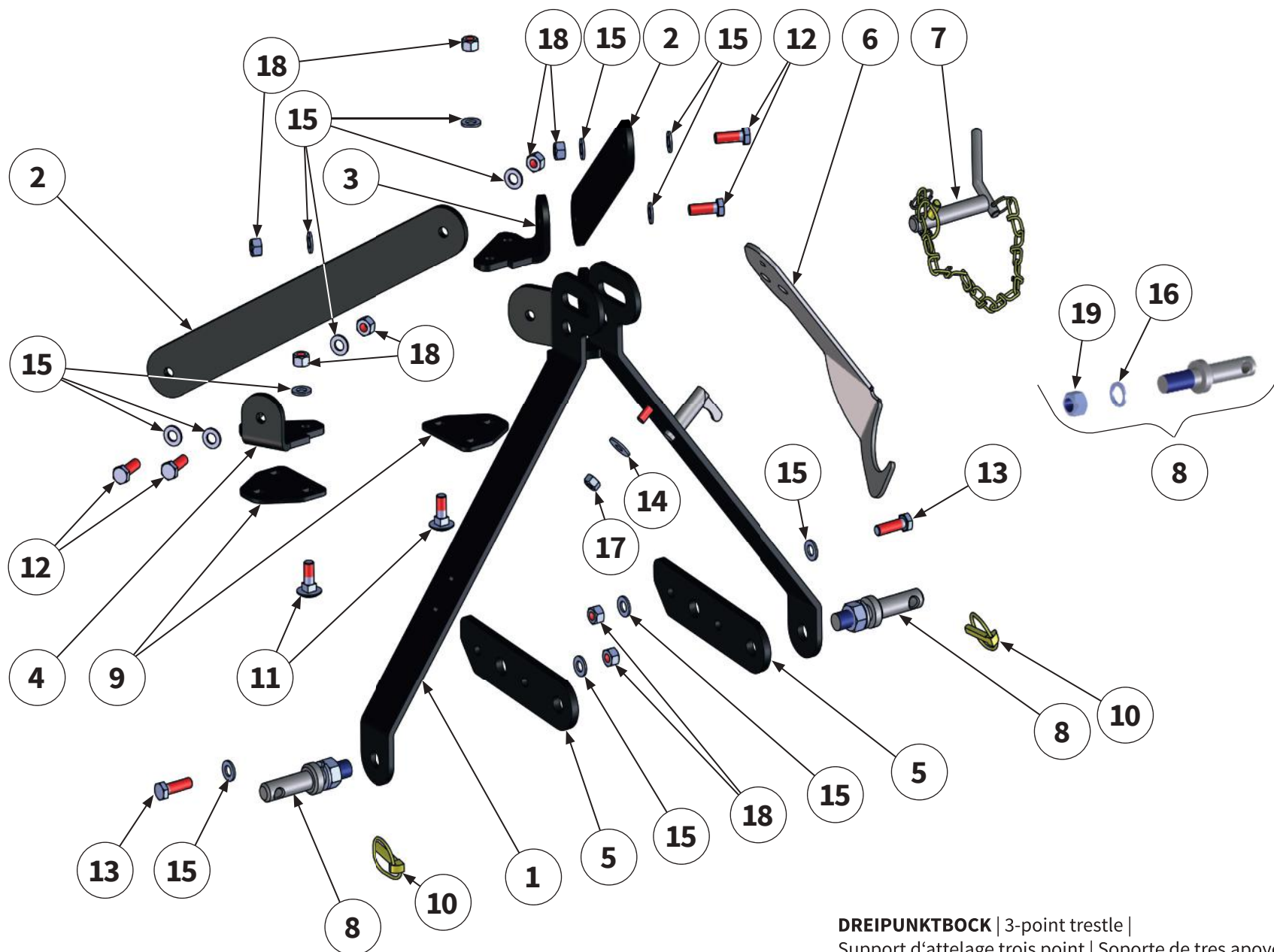

Pos.-Nr. No. Numéro Número	Ersatzteilnummer Manufacturer part number Numéro de pièce du fabricant Número de pieza del fabricante				DE Bezeichnung	EN Designation	FR Désignation	ES Designación
	Anzahl quantity quantité número							
	MU-C 100	MU-C 120	MU-C 140	MU-C 160				
14	MU0099950				Scheibe	washer	Disque	Arandela
	1	1	1	1				
15	MU980302				Scheibe	washer	Disque	Arandela
	22	22	22	22				
16	MU982030				Federring	spring washer	Rondelle élastique	Anillo elástico
	2	2	2	2				
17	MU0099960				Mutter	nut	Écrou	Tuerca
	1	1	1	1				
18	MU980301				Mutter	nut	Écrou	Tuerca
	14	14	14	14				
19	MU980504				Mutter	nut	Écrou	Tuerca
	2	2	2	2				



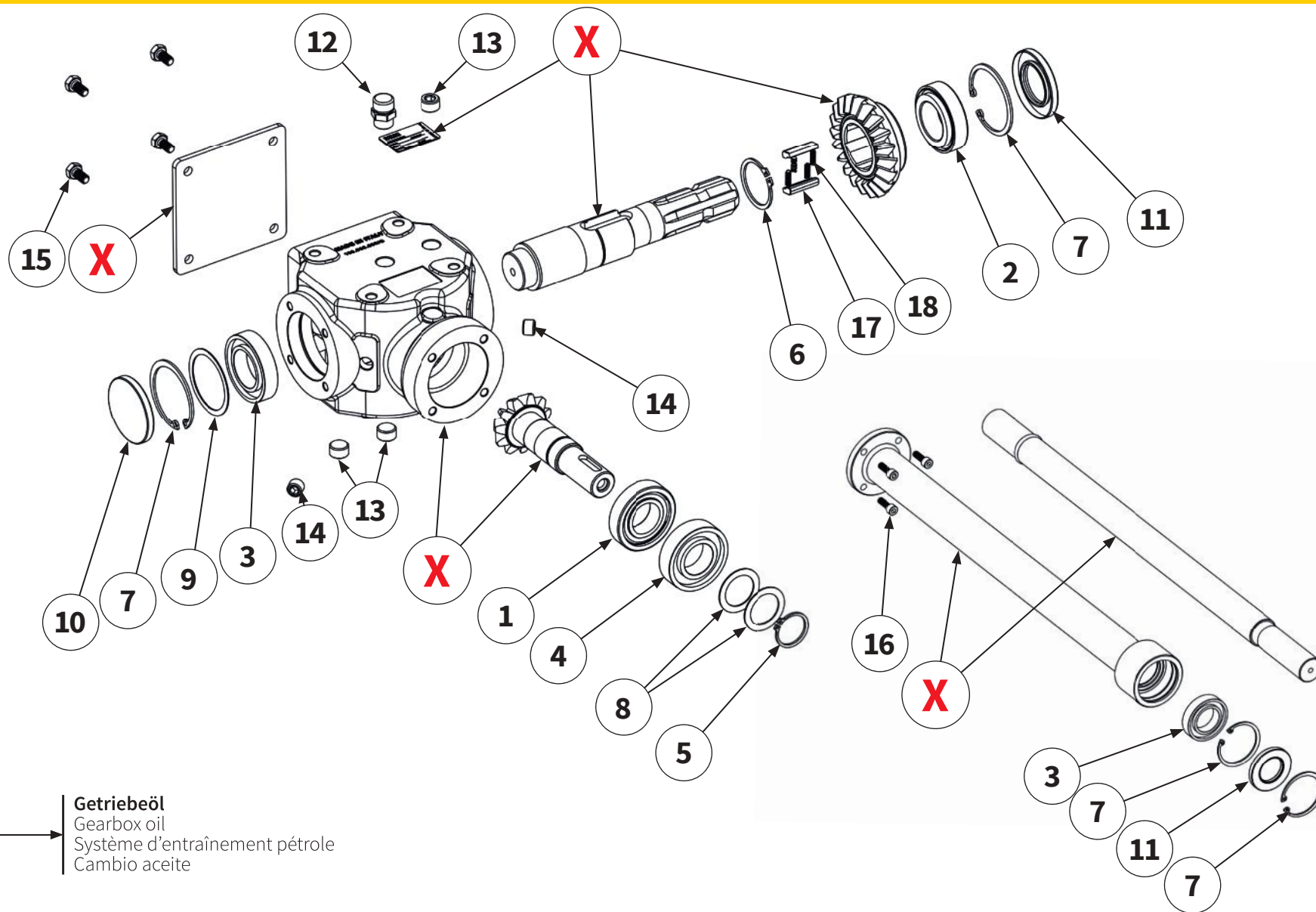

19 → **Getriebeöl**
 Gearbox oil
 Système d'entraînement pétrole
 Cambio aceite

Pos.-Nr. No. Numéro Número	Ersatzteilnummer Manufacturer part number Numéro de pièce du fabricant Número de pieza del fabricante				DE Bezeichnung	EN Designation	FR Désignation	ES Designación
	Anzahl quantity quantité número							
	MU-C 100	MU-C 120	MU-C 140	MU-C 160				
1	MU200006				Lager	bearing	Palier	Cojinete
	1	1	1	1				
2	MUR20217				Lager	bearing	Palier	Cojinete
	1	1	1	1				
3	MUR20216				Lager	bearing	Palier	Cojinete
	2	2	2	1				
4	MU200009				Lager	bearing	Palier	Cojinete
	1	1	1	1				
5	MU280031				Sicherungsring	circlip	Bague de sécurité	Anillo de seguridad
	1	1	1	1				
6	MU623013				Sicherungsring	circlip	Bague de sécurité	Anillo de seguridad
	1	1	1	1				
7	MU200014				Sicherungsring	circlip	Bague de sécurité	Anillo de seguridad
	3	3	3	3				
8	MU200017				Distanzscheibe	spacer	Disque d'écartement	Arandela distanciadora
	2	2	2	2				
9	MUR20213				Distanzscheibe	spacer	Disque d'écartement	Arandela distanciadora
	2	2	2	2				
10	MUR20205				Verschlussdeckel	cap	Couvercie de fermeture	Tapa de cierre
	1	1	1	1				
11	MUTR4013				Wellendichtring	shaft seal	Baque d'levre	Retén de eye
	2	2	2	2				
12	MU623018				Getriebe-entlüftung	gearbox breather	Boîte de vitesses reniflard	Respiradero de la caja de cambios
	1	1	1	1				
X	Teile einzeln vom Hersteller nicht lieferbar Parts from the manufacturer cannot be supplied individually Pièces non livrables séparément par le fabricant El fabricante no suministra piezas individuales							

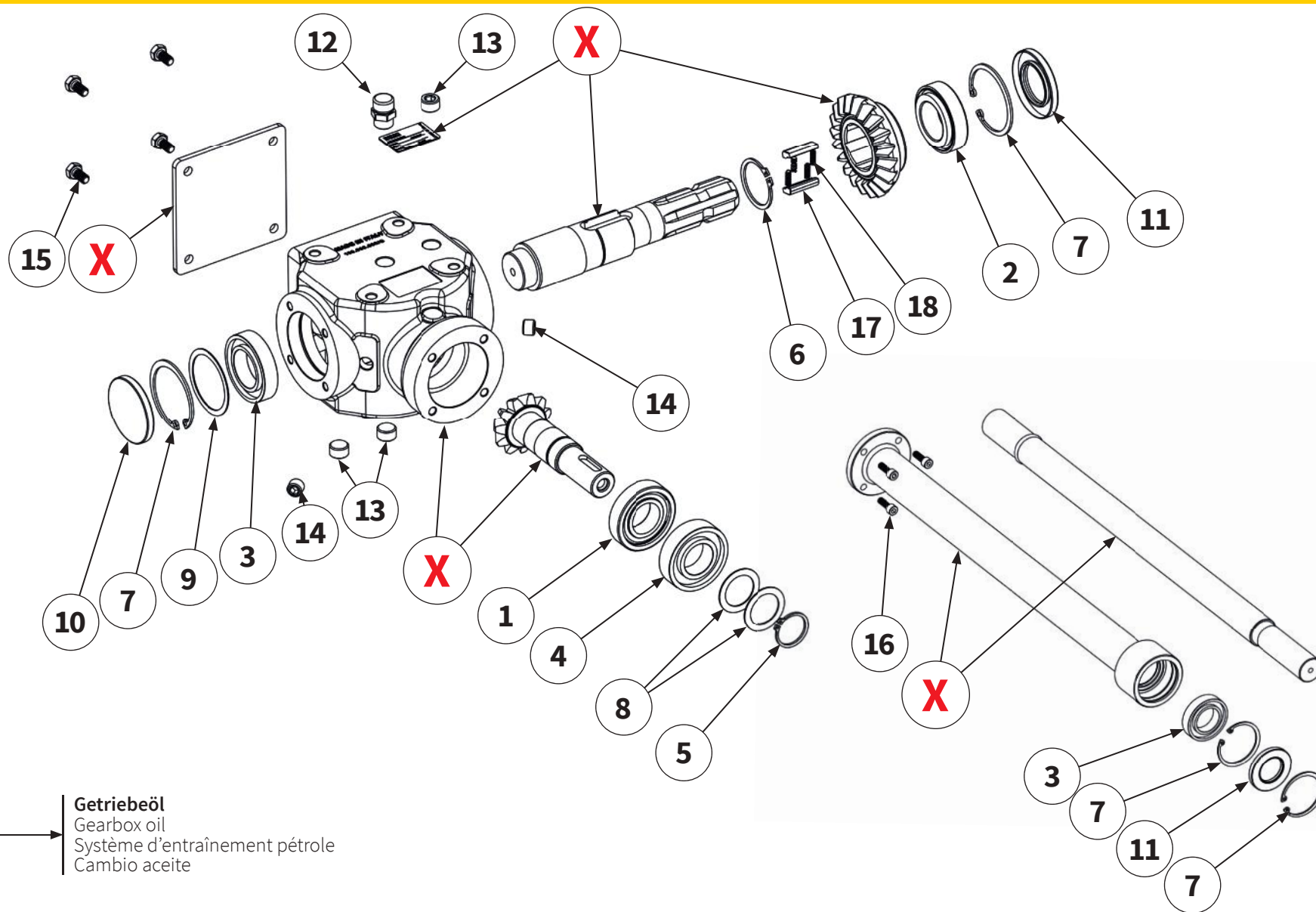

19 → **Getriebeöl**
 Gearbox oil
 Système d'entraînement pétrole
 Cambio aceite

Pos.-Nr. No. Numéro Número	Ersatzteilnummer Manufacturer part number Numéro de pièce du fabricant Número de pieza del fabricante				DE Bezeichnung	EN Designation	FR Désignation	ES Designación
	Anzahl quantity quantité número							
	MU-C 100	MU-C 120	MU-C 140	MU-C 160				
13	MU623017				Ablass- kontrollschraube	bolt	Vis	Tornillo
	3	3	3	3				
14	MU310018				Ablass- kontrollschraube	bolt	Vis	Tornillo
	2	2	2	2				
15	MU982811				Schraube	bolt	Vis	Tornillo
	4	4	4	4				
16	MU980110				Schraube	bolt	Vis	Tornillo
	4	4	4	4				
17	MU623008-BRM				Sperrklinke	detent freewheel	Cliquet d'arrêt roue libre	Trinquete de bloqueo rueda libre
	2	2	2	2				
18	MU623021-BRM				Feder	spring	Ressort	Resorte
	4	4	4	4				
19	MUSAE70W90VS (1l)				Getriebeöl	gearbox oil	Système d'entraînement pétrole	Cambio aceite
	1	1	1	1				
19a	0,7 l				Füllmenge	Oil fill quantity i	Quantité d'huile	Cantidad de llenado de aceite
X	Teile einzeln vom Hersteller nicht lieferbar Parts from the manufacturer cannot be supplied individually Pièces non livrables séparément par le fabricant El fabricante no suministra piezas individuales							

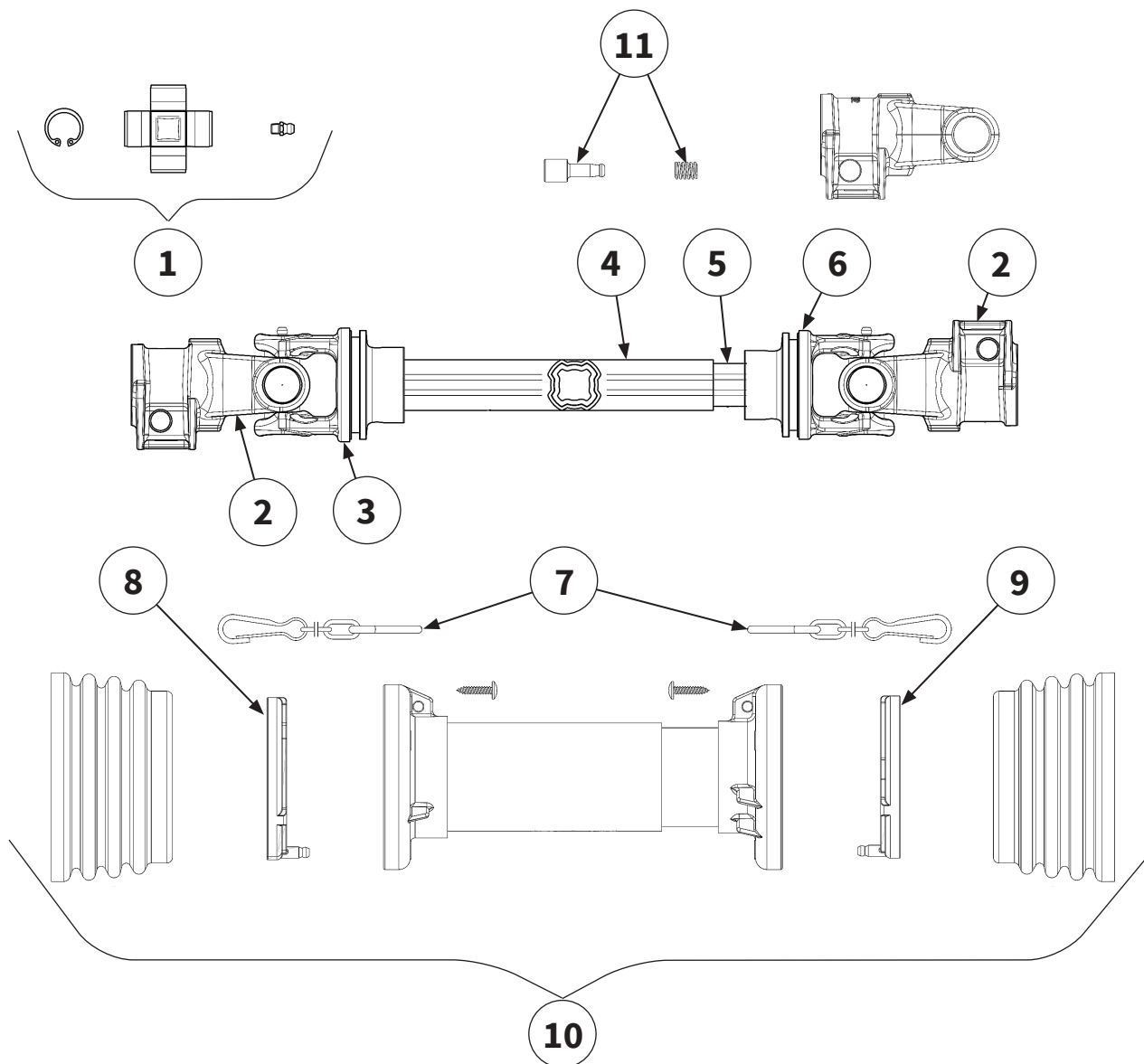

Pos.-Nr. No. Número	Ersatzteilnummer Manufacturer part number Numéro de pièce du fabricant Número de pieza del fabricante				DE Bezeichnung	EN Designation	FR Désignation	ES Designación
	Anzahl quantity quantité número							
	MU-C 100	MU-C 120	MU-C 140	MU-C 160				
1	4120B0012R50				Kreuzgarnitur	Cross Kit	Croisillon	Crucetas
	2	2	2	2				
2	5070B0355				Außengabel	Outer Yoke	Mâchoire	Horquilla
	2	2	2	2				
3	204S16853				Innengabel für Außenrohr	Outer Yoke Teleskop-Tube	Mâchoire pour tube extérieur	Horquilla para tubo exterior
	1	1	1	1				
4	122321000				Profil-Außenrohr	Outer Telescope Tube	Tube externe	Tubo exterior
	1	1	1	1				
5	122161000				Profil-Innenrohr	Inner Telescope Tube	Tube interne	Tubo interior
	1	1	1	1				
6	204S16854				Innengabel für Innenrohr	Inner Yoke Telescope Tube	Mâchoire pour tube intérieur	Horquilla para tubo interior
	1	1	1	1				
7	252000050R02				Haltekette	chain	Chaîne de retenue	Cadena de seguridad
	2	2	2	2				
8	2550A0001R02				Lauftring	Raceway	Palier de glisse- ment	Anillo soporte
	1	1	1	1				
9	2550A0002R02				Lauftring	Raceway	Palier de glisse- ment	Anillo soporte
	1	1	1	1				
10	5CS1086FXSS				Gelenkwellen- schutz	Safety Shield complete	Protection contre les accidents	Protecciones de seguridad
	1	1	1	1				
11	403000021R10				Schiebestift	Push Pin Kit	Veru rapide	Pulsador
	2	2	2	2				

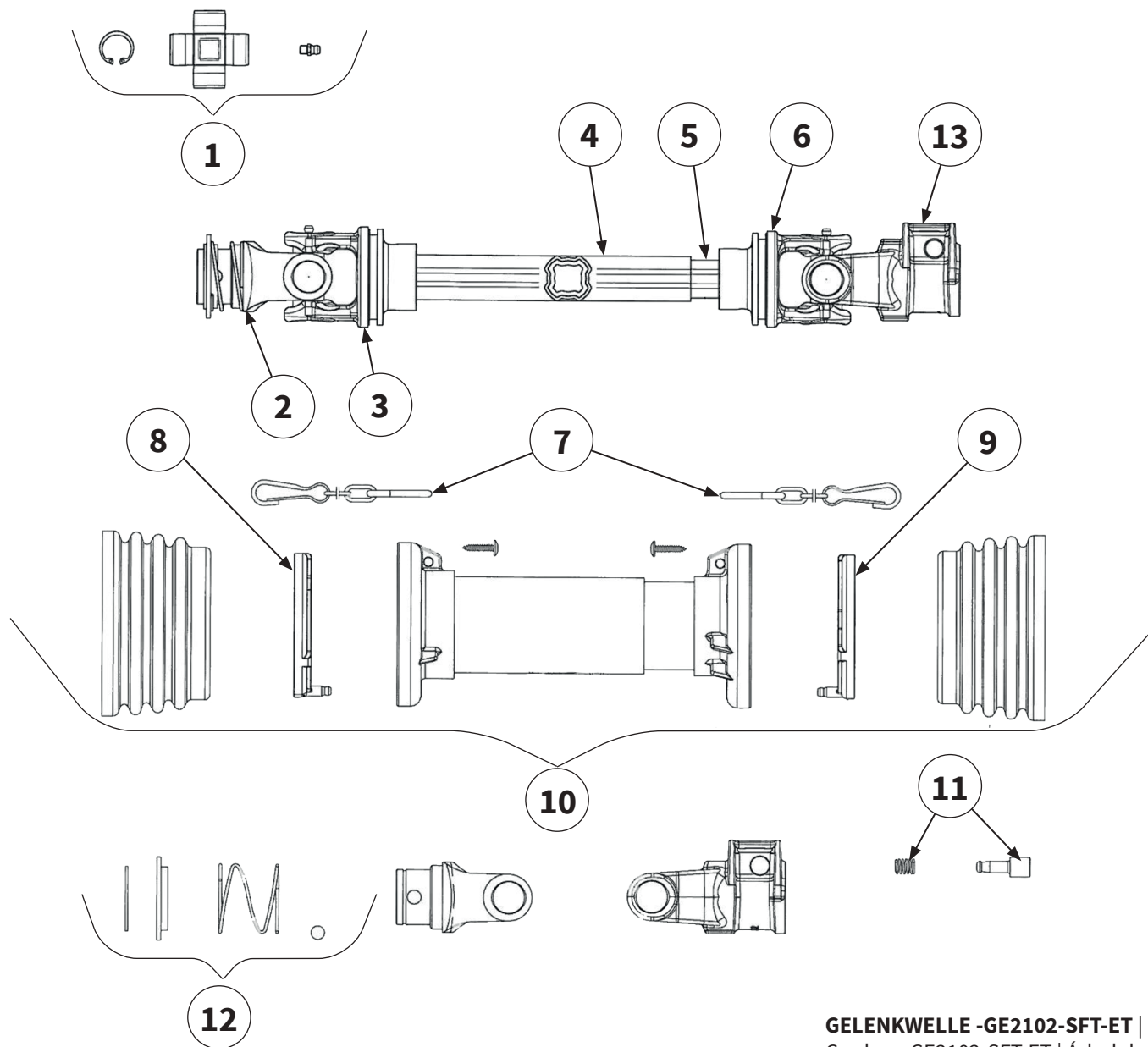

Pos.-Nr. No. Número	Ersatzteilnummer Manufacturer part number Numéro de pièce du fabricant Número de pieza del fabricante				DE Bezeichnung	EN Designation	FR Désignation	ES Designación
	Anzahl quantity quantité número							
	MU-C 100	MU-C 120	MU-C 140	MU-C 160				
1	4120B0012R50				Kreuzgarnitur	Cross Kit	Croisillon	Crucetas
	2	2	2	2				
2	505010651				Außengabel	Outer Yoke	Mâchoire	Horquilla
	1	1	1	1				
3	204S16853				Innengabel für Außenrohr	Outer Yoke Teleskop-Tube	Mâchoire pour tube extérieur	Horquilla para tubo exterior
	1	1	1	1				
4	122321000				Profil-Außenrohr	Outer Telescope Tube	Tube externe	Tubo exterior
	1	1	1	1				
5	122161000				Profil-Innenrohr	Inner Telescope Tube	Tube interne	Tubo interior
	1	1	1	1				
6	204S16854				Innengabel für Innenrohr	Inner Yoke Telescope Tube	Mâchoire pour tube intérieur	Horquilla para tubo interior
	1	1	1	1				
7	252000050R02				Haltekette	chain	Chaîne de retenue	Cadena de seguridad
	2	2	2	2				
8	2550A0001R02				Lauftring	Raceway	Palier de glisse- ment	Anillo soporte
	1	1	1	1				
9	2550A0002R02				Lauftring	Raceway	Palier de glisse- ment	Anillo soporte
	1	1	1	1				
10	5CS1086FXSS				Gelenkwellen- schutz	Safety Shield complete	Protection contre les accidents	Protecciones de seguridad
	1	1	1	1				
11	403000021R10				Schiebestift	Push Pin Kit	Veru rapide	Pulsador
	1	1	1	1				
12	240002021R				Ziehverschluß	Pull Lock	Obturateur	Obturador
	1	1	1	1				
13	5070B0355				Außengabel	Outer Yoke	Mâchoire	Horquilla
	1	1	1	1				

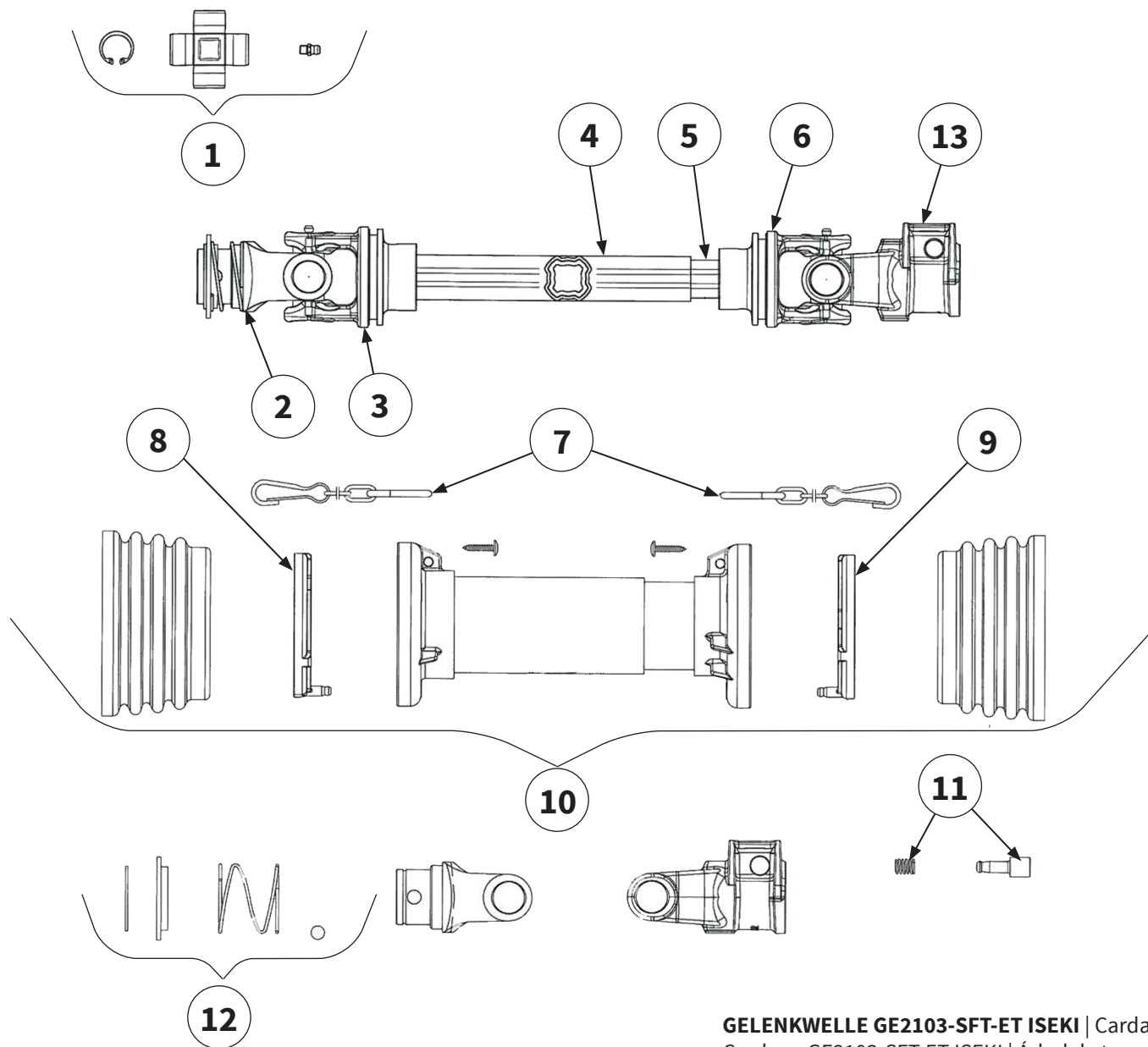

Pos.-Nr. No. Número	Ersatzteilnummer Manufacturer part number Numéro de pièce du fabricant Número de pieza del fabricante				DE Bezeichnung	EN Designation	FR Désignation	ES Designación
	Anzahl quantity quantité número							
	MU-C 100	MU-C 120	MU-C 140	MU-C 160				
1	4120B0012R50				Kreuzgarnitur	Cross Kit	Croisillon	Crucetas
	2	2	2	2				
2	5050B0951				Außengabel	Outer Yoke	Mâchoire	Horquilla
	1	1	1	1				
3	204S16853				Innengabel für Außenrohr	Outer Yoke Teleskop-Tube	Mâchoire pour tube extérieur	Horquilla para tubo exterior
	1	1	1	1				
4	122321000				Profil-Außenrohr	Outer Telescope Tube	Tube externe	Tubo exterior
	1	1	1	1				
5	122161000				Profil-Innenrohr	Inner Telescope Tube	Tube interne	Tubo interior
	1	1	1	1				
6	204S16854				Innengabel für Innenrohr	Inner Yoke Telescope Tube	Mâchoire pour tube intérieur	Horquilla para tubo interior
	1	1	1	1				
7	252000050R02				Haltekette	chain	Chaîne de retenue	Cadena de seguridad
	2	2	2	2				
8	2550A0001R02				Lauftring	Raceway	Palier de glisse- ment	Anillo soporte
	1	1	1	1				
9	2550A0002R02				Lauftring	Raceway	Palier de glisse- ment	Anillo soporte
	1	1	1	1				
10	5CS1086FXSS				Gelenkwellen- schutz	Safety Shield complete	Protection contre les accidents	Protecciones de seguridad
	1	1	1	1				
11	403000021R10				Schiebestift	Push Pin Kit	Veru rapide	Pulsador
	1	1	1	1				
12	435000901R				Ziehverschluß	Pull Lock	Obturateur	Obturador
	1	1	1	1				
13	5070B0355				Außengabel	Outer Yoke	Mâchoire	Horquilla
	1	1	1	1				

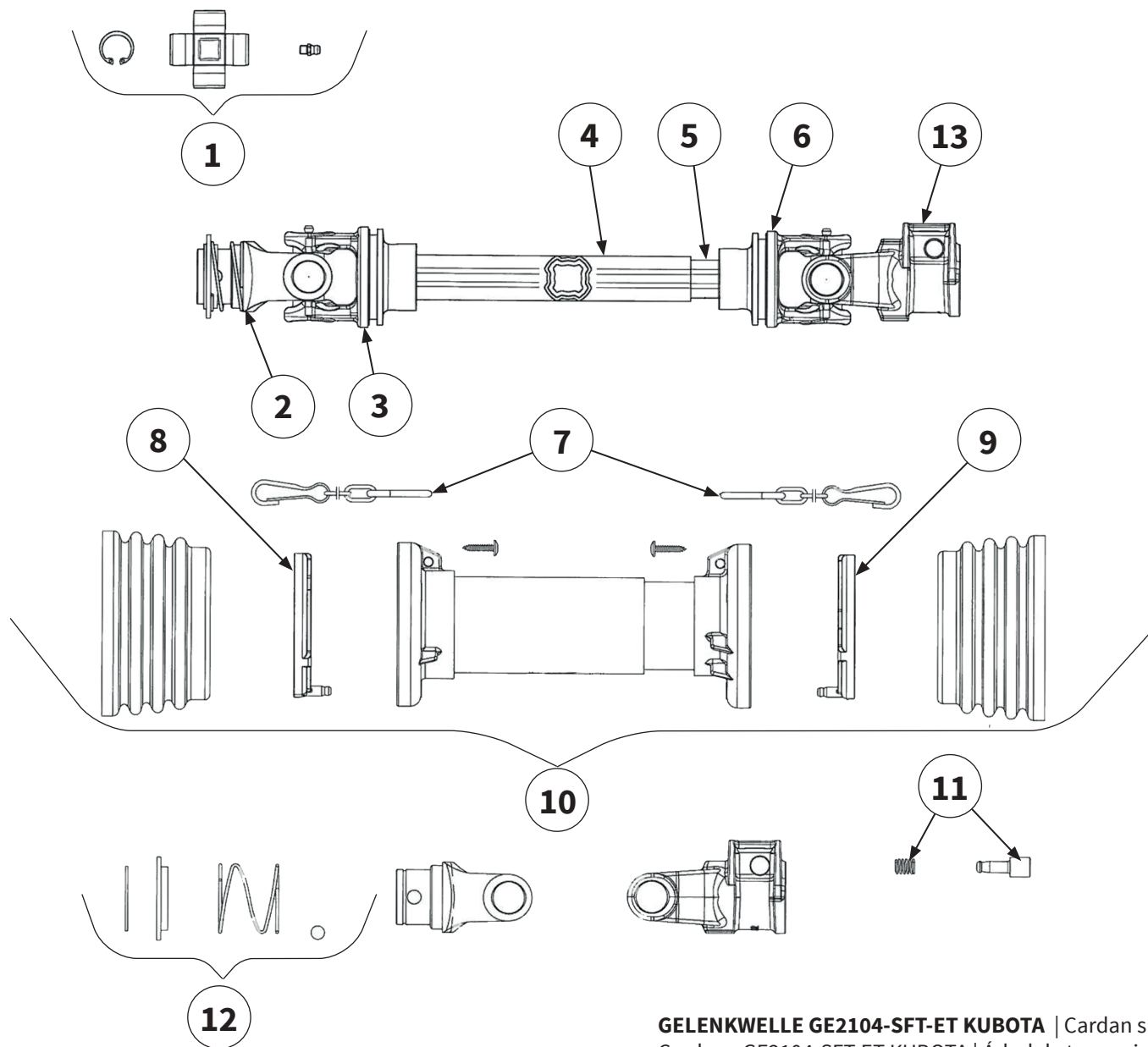

Pos.-Nr. No. Número	Ersatzteilnummer Manufacturer part number Numéro de pièce du fabricant Número de pieza del fabricante				DE Bezeichnung	EN Designation	FR Désignation	ES Designación
	Anzahl quantity quantité número							
	MU-C 100	MU-C 120	MU-C 140	MU-C 160				
1	4120B0012R50				Kreuzgarnitur	Cross Kit	Croisillon	Crucetas
	2	2	2	2				
2	5070B0355				Außengabel	Outer Yoke	Mâchoire	Horquilla
	1	1	1	1				
3	204S16853				Innengabel für Außenrohr	Outer Yoke Teleskop-Tube	Mâchoire pour tube extérieur	Horquilla para tubo exterior
	1	1	1	1				
4	122321000				Profil-Außenrohr	Outer Telescope Tube	Tube externe	Tubo exterior
	1	1	1	1				
5	122161000				Profil-Innenrohr	Inner Telescope Tube	Tube interne	Tubo interior
	1	1	1	1				
6	204S16854				Innengabel für Innenrohr	Inner Yoke Telescope Tube	Mâchoire pour tube intérieur	Horquilla para tubo interior
	1	1	1	1				
7	252000050R02				Haltekette	chain	Chaîne de retenue	Cadena de seguridad
	2	2	2	2				
8	2550A0001R02				Lauftring	Raceway	Palier de glisse- ment	Anillo soporte
	1	1	1	1				
9	2550A0002R02				Lauftring	Raceway	Palier de glisse- ment	Anillo soporte
	1	1	1	1				
10	5CS1086FXSS				Gelenkwellen- schutz	Safety Shield complete	Protection contre les accidents	Protecciones de seguridad
	1	1	1	1				
11	403000021R10				Schiebestift	Push Pin Kit	Veru rapide	Pulsador
	1	1	1	1				
12	240002021R				Ziehverschluß	Pull Lock	Obturateur	Obturador
	1	1	1	1				
13	505014062				Außengabel	Outer Yoke	Mâchoire	Horquilla
	1	1	1	1				

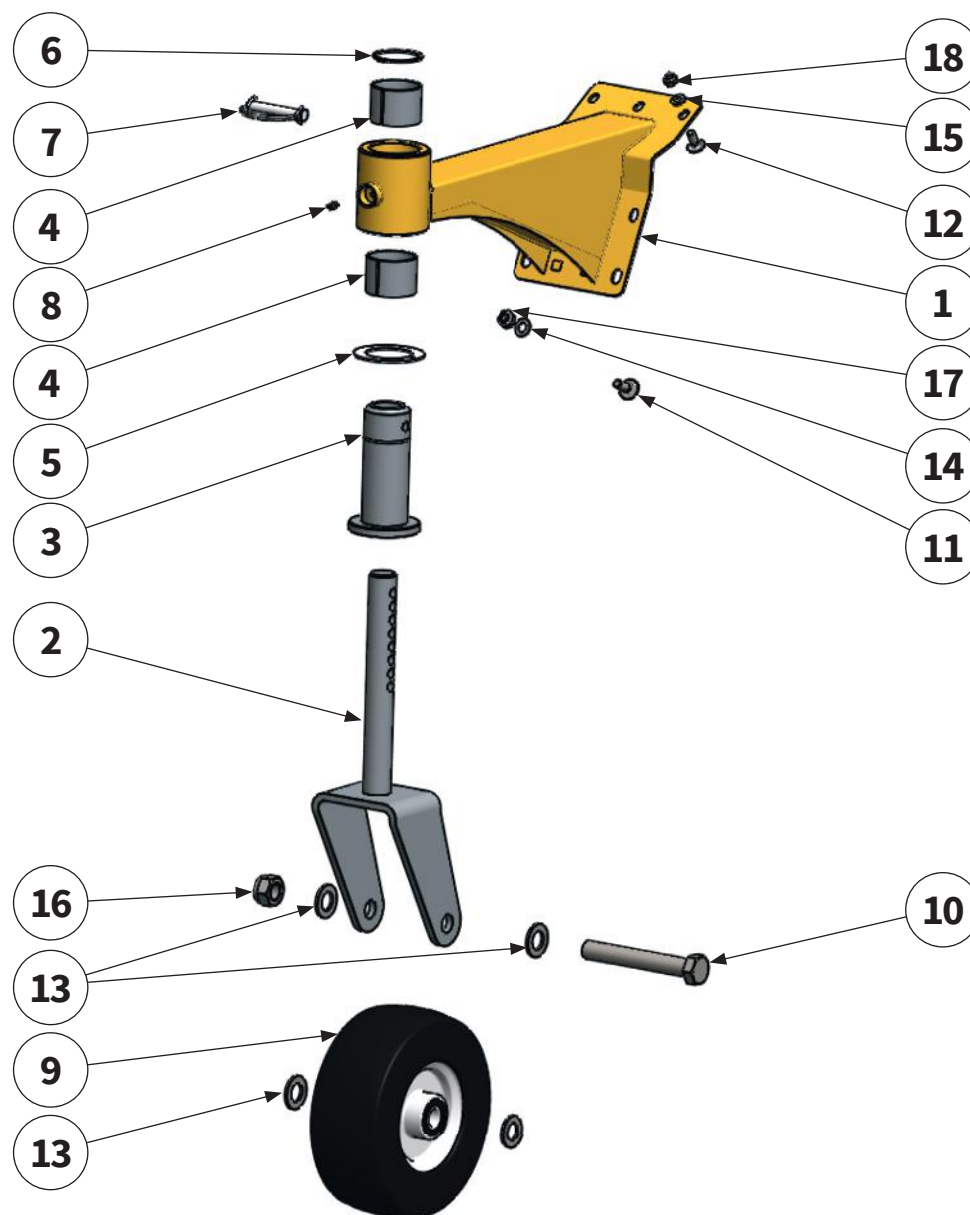

Pos.-Nr. No. Número	Ersatzteilnummer Manufacturer part number Numéro de pièce du fabricant Número de pieza del fabricante				DE Bezeichnung	EN Designation	FR Désignation	ES Designación
	Anzahl quantity quantité número							
	MU-C 100	MU-C 120	MU-C 140	MU-C 160				
1	00031225				Stützradträger	support wheel carrier	Support de la roue d'appui	Soporte de la rueda de soporte
	1	1	1	1				
2	MU0110751				Radgabel	wheel yoke	Fourche de roue	Horquilla de rueda
	1	1	1	1				
3	MU0211071				Buchse	bush	Douille	Casquillo
	2	2	2	2				
4	MU0211111				Gleitlagerbuchse	plain bearing bush	Coussinet lisse	Casquillo de cojinete liso
	2	2	2	2				
5	MU0211101				Anlaufscheibe	thrust washer	Rondelle de butée	Arandela de tope
	1	1	1	1				
6	MU0099990				Sicherungsring	circlip	Bague de sécurité	Anillo de seguridad
	1	1	1	1				
7	MU0099946				Rohrklappstecker	pipe lynch pin	Goupille rabattable	Conector de tapa de tubo
	1	1	1	1				
8	DIN71412A-H1-M06X1				Schmiernippel	lubricating nipple	Nipple de graissage	Engrasador
	1	1	1	1				
9	MU0211091-3				Stützrad	support wheel	Roue d'appui	Rueda de soporte
	1	1	1	1				
10	MU0099977				Schraube	bolt	Vis	Tornillo
	1	1	1	1				

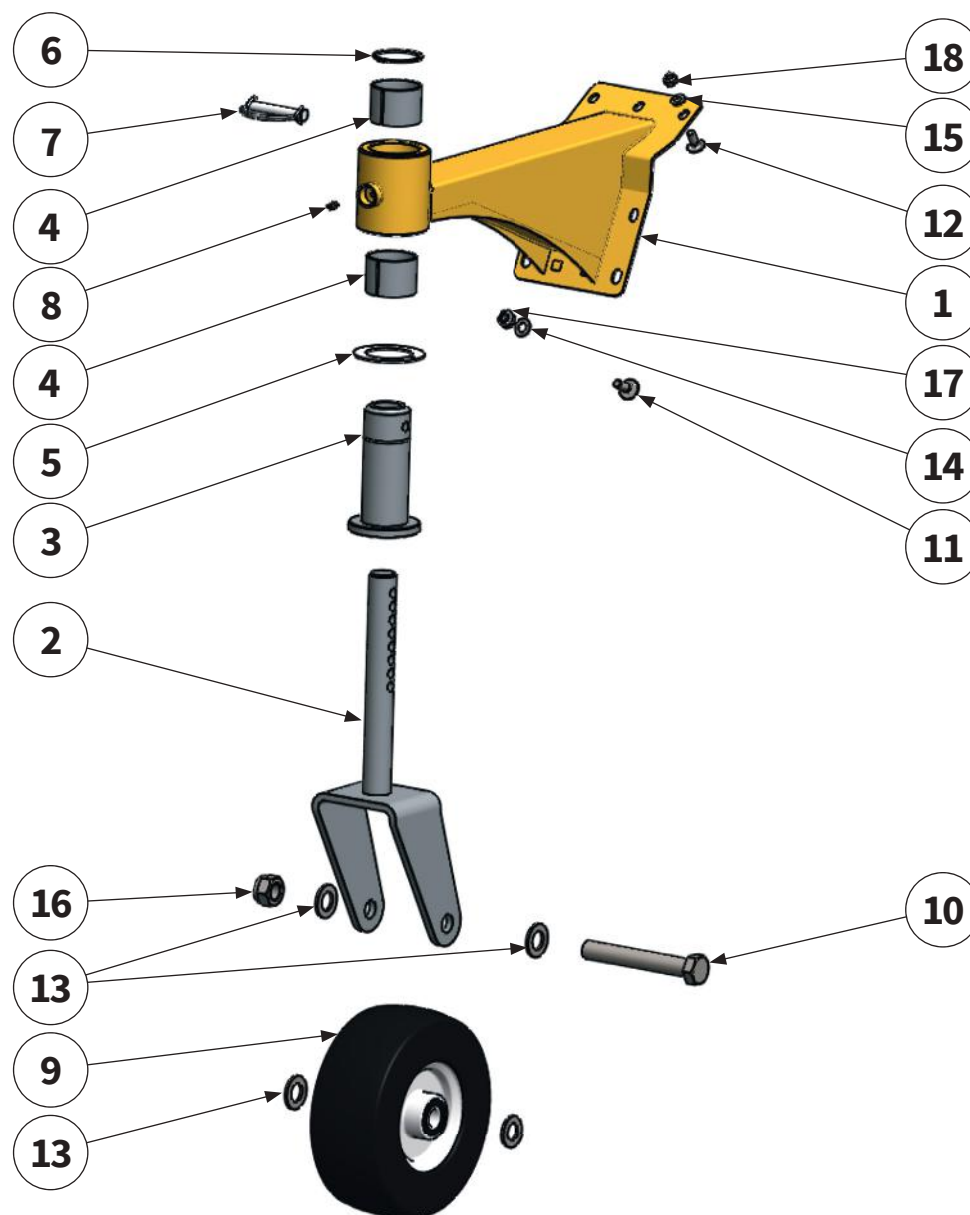

Pos.-Nr. No. Numéro Número	Ersatzteilnummer Manufacturer part number Numéro de pièce du fabricant Número de pieza del fabricante				DE Bezeichnung	EN Designation	FR Désignation	ES Designación
	Anzahl quantity quantité número							
	MU-C 100	MU-C 120	MU-C 140	MU-C 160				
11	0000903				Schraube	bolt	Vis	Tornillo
	2	2	2	2				
12	MU980107				Schraube	bolt	Vis	Tornillo
	5	5	5	5				
13	MU980505				Scheibe	washer	Disque	Arandela
	4	4	4	4				
14	MU980202				Scheibe	washer	Disque	Arandela
	2	2	2	2				
15	MU0099999				Scheibe	washer	Disque	Arandela
	5	5	5	5				
16	MU0099959				Mutter	nut	Écrou	Tuerca
	1	1	1	1				
17	MU0099960				Mutter	nut	Écrou	Tuerca
	2	2	2	2				
18	MU0099961				Mutter	nut	Écrou	Tuerca
	5	5	5	5				



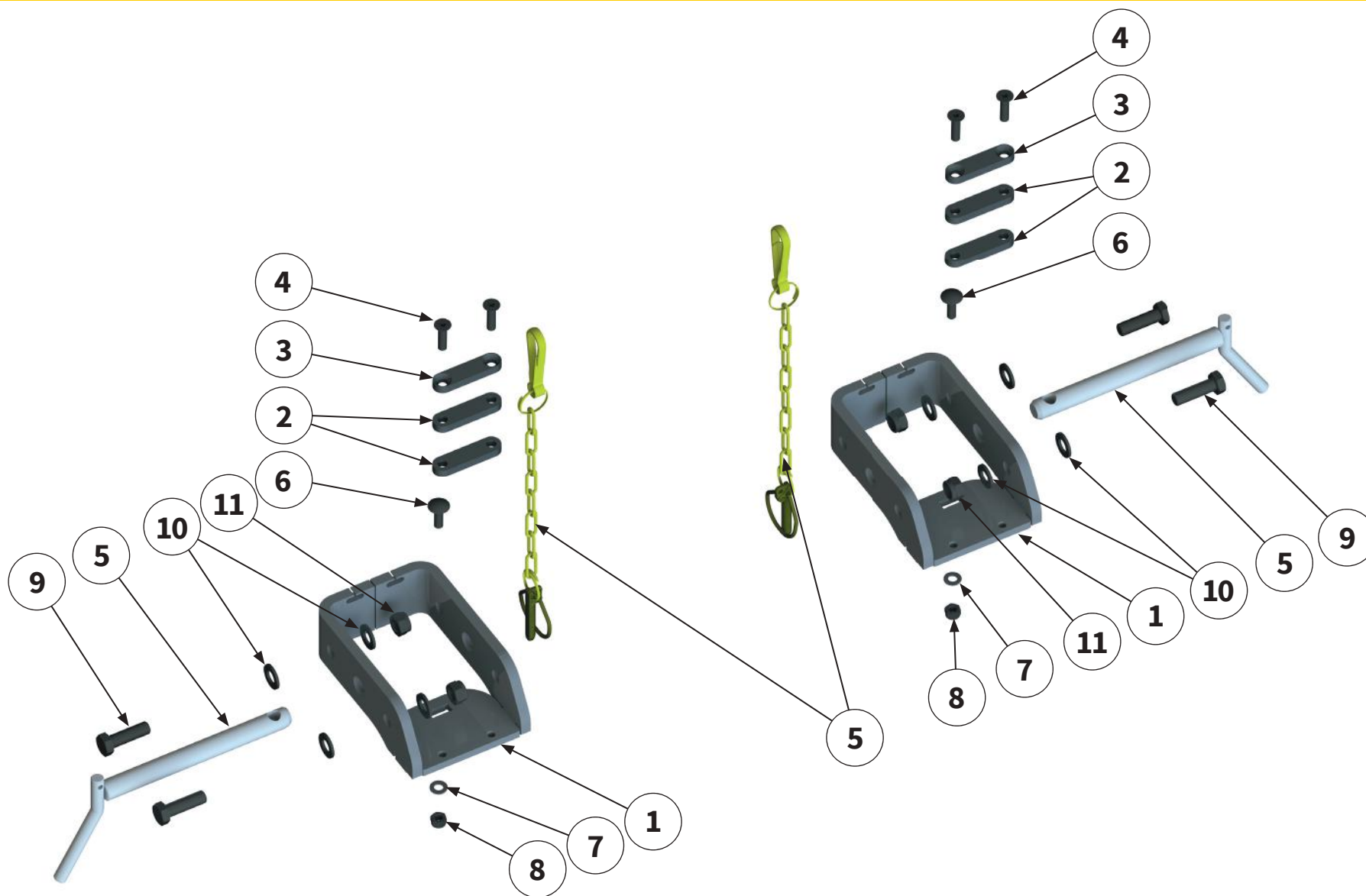

Pos.-Nr. No. Número	Ersatzteilnummer Manufacturer part number Numéro de pièce du fabricant Número de pieza del fabricante				DE Bezeichnung	EN Designation	FR Désignation	ES Designación
	Anzahl quantity quantité número							
	MU-C 100	MU-C 120	MU-C 140	MU-C 160				
1	00014797				Unterlenkeraufnahme	lower link receiver	Logement du bras inférieur	Alojamiento del brazo inferior
	2	2	2	2				
2	00014793				Distanzblech	spacer plate	Tôle d'écartement	Chapa distanciadora
	4	4	4	4				
3	00014792				Blech	sheet metal	Tôle	Chapa
	2	2	2	2				
4	MU0099952				Schraube	bolt	Vis	Tornillo
	4	4	4	4				
5	00001787				Bolzen	pin	axe	Perno
	2	2	2	2				
6	MU0099988				Schraube	bolt	Vis	Tornillo
	2	2	2	2				
7	MU0099999				Scheibe	washer	Disque	Arandela
	2	2	2	2				
8	MU0099961				Mutter	nut	Écrou	Tuerca
	2	2	2	2				
9	MU980328				Schraube	bolt	Vis	Tornillo
	4	4	4	4				
10	MU980302				Scheibe	washer	Disque	Arandela
	8	8	8	8				
11	MU980301				Mutter	nut	Écrou	Tuerca
	4	4	4	4				



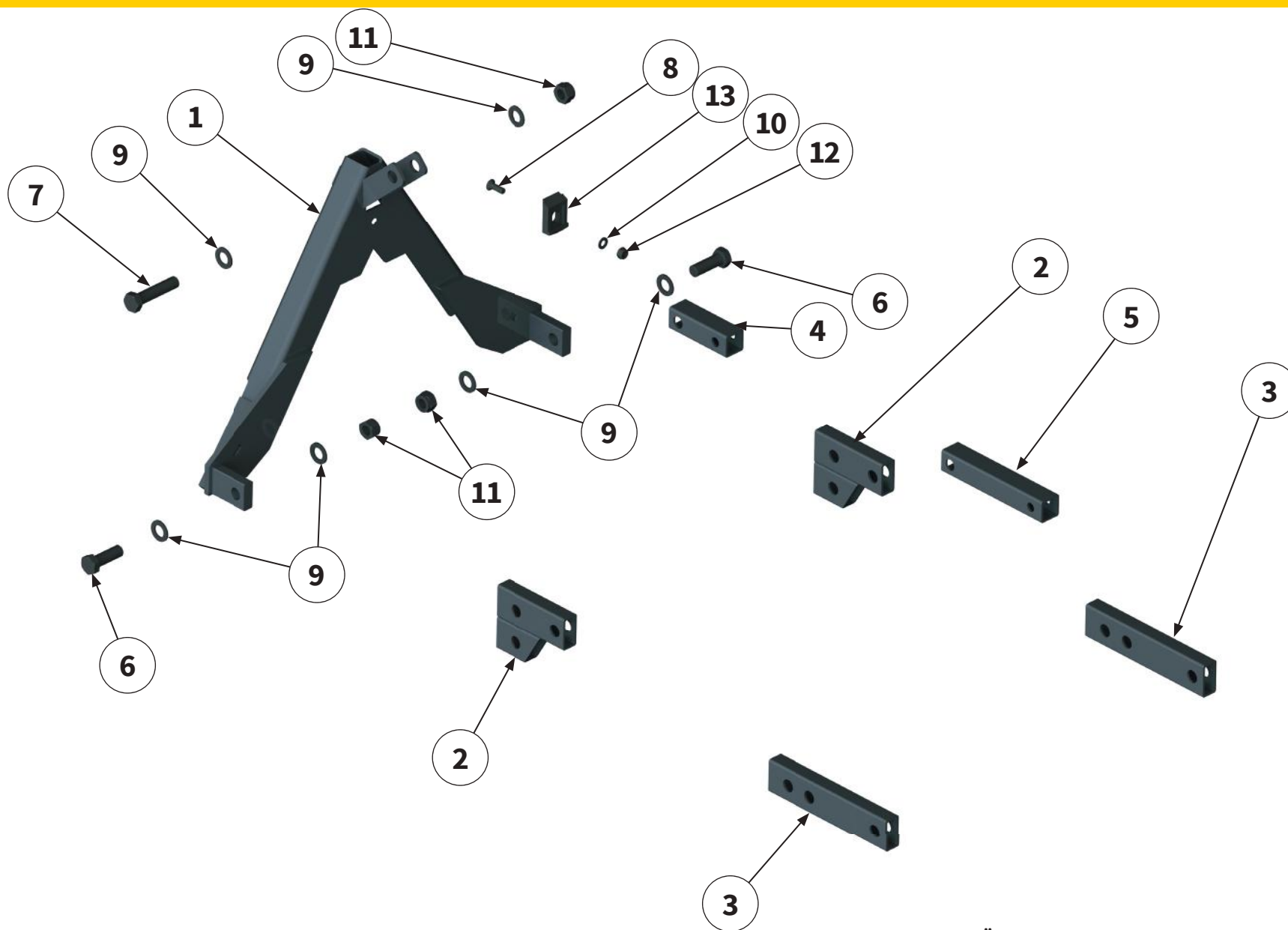

Pos.-Nr. No. Número	Ersatzteilnummer Manufacturer part number Numéro de pièce du fabricant Número de pieza del fabricante				DE Bezeichnung	EN Designation	FR Désignation	ES Designación
	Anzahl quantity quantité número							
	MU-C 100	MU-C 120	MU-C 140	MU-C 160				
1	00014510				Gerätedreieck	implement triangle	Triangle d'attelage	Triángulo del dispositivo
	1	1	1	1				
2	00030696				Unterlenker- aufnahme	lower link receiver	Logement du bras inférieur	Alojamiento del brazo inferior
	2	2	2	2				
3	00014514				Profilrohr	section tube	Tube de section	Tubo de sección
	2	2	2	2				
4	00014511				Profilrohr	section tube	Tube de section	Tubo de sección
	1	1	1	1				
5	00014512				Profilrohr	section tube	Tube de section	Tubo de sección
	1	1	1	1				
6	MU981008				Schraube	bolt	Vis	Tornillo
	2	2	2	2				
7	MU980529				Schraube	bolt	Vis	Tornillo
	1	1	1	1				
8	MU980252				Schraube	bolt	Vis	Tornillo
	1	1	1	1				
9	MU980505				Scheibe	washer	Disque	Arandela
	6	6	6	6				
10	MU980202				Scheibe	washer	Disque	Arandela
	1	1	1	1				
11	MU0099959				Mutter	nut	Écrou	Tuerca
	3	3	3	3				
12	MU0099960				Mutter	nut	Écrou	Tuerca
	1	1	1	1				
13	MU0011071				Sperrklinke	detent freewheel	Cliquet d'arrêt roue libre	Trinquete de bloqueo rueda libre
	1	1	1	1				



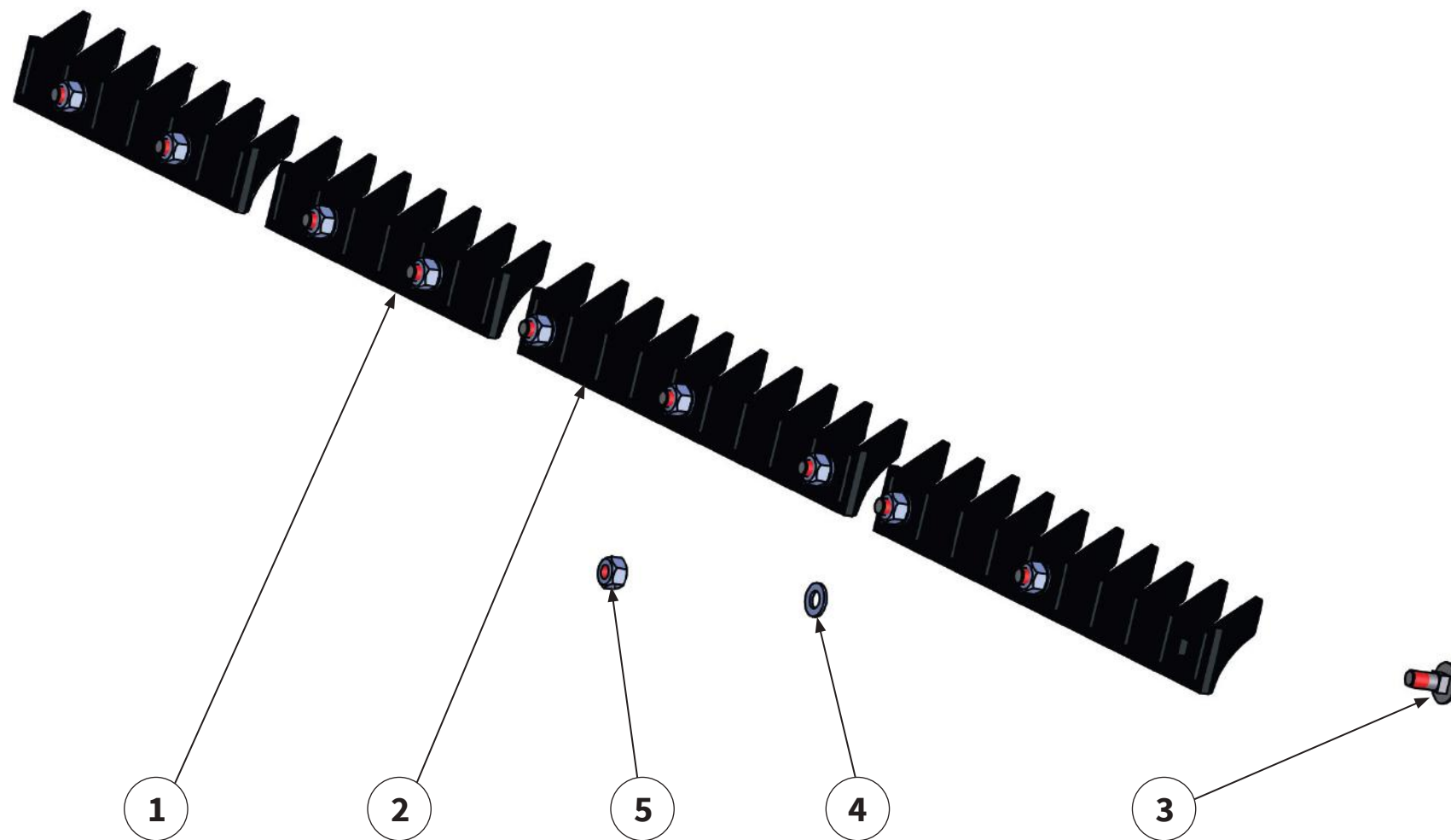

Pos.-Nr. No. Numéro Número	Ersatzteilnummer Manufacturer part number Numéro de pièce du fabricant Número de pieza del fabricante				DE Bezeichnung	EN Designation	FR Désignation	ES Designación
	Anzahl quantity quantité número							
	MU-C 100	MU-C 120	MU-C 140	MU-C 160				
1	00005472				Gegenschneide 300	short-chopping bar	Lame hache-paille courte	Listón de corte de paja corto
	2	-	2	-				
2	00005474				Gegenschneide 400	short-chopping bar	Lame hache-paille courte	Listón de corte de paja corto
	1	3	2	4				
3	00000903				Schraube	bolt	Vis	Tornillo
	7	9	10	12				
4	MU980202				Scheibe	washer	Disque	Arandela
	7	9	10	12				
5	MU0099960				Mutter	nut	Écrou	Tuerca
	7	9	10	12				



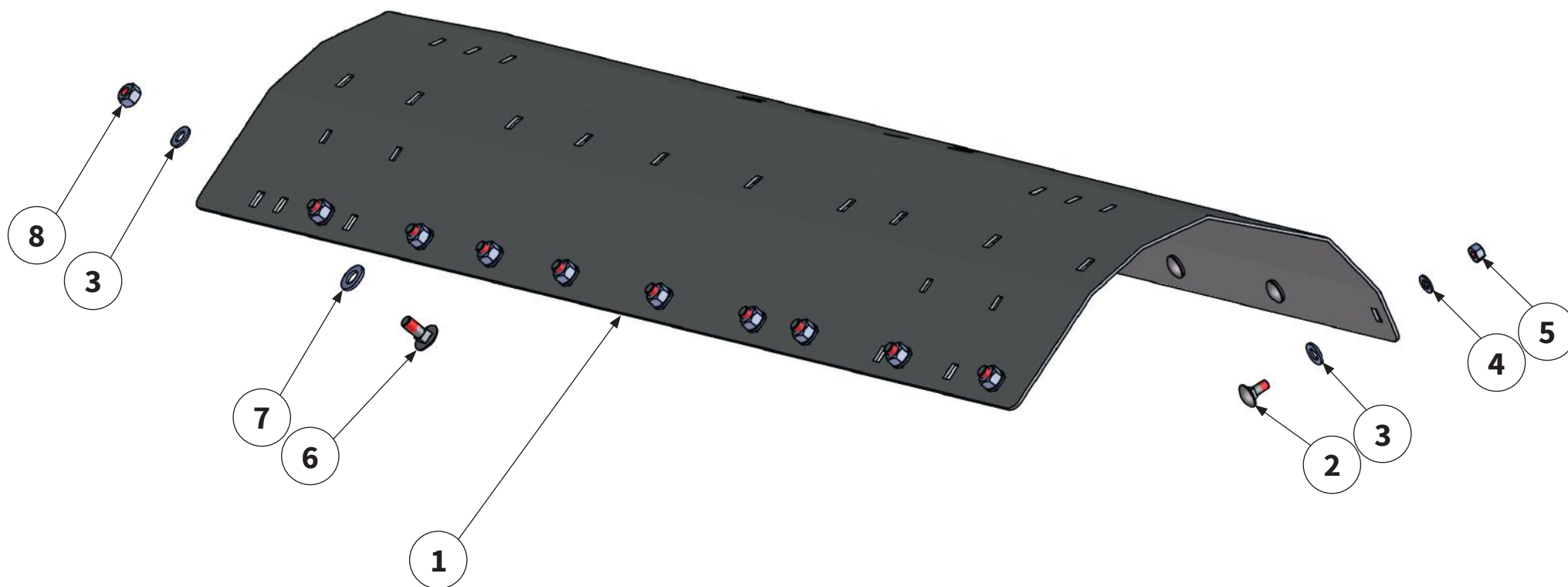

Pos.-Nr. No. Numéro Número	Ersatzteilnummer Manufacturer part number Numéro de pièce du fabricant Número de pieza del fabricante				DE Bezeichnung	EN Designation	FR Désignation	ES Designación
	Anzahl quantity quantité número							
	MU-C 100	MU-C 120	MU-C 140	MU-C 160				
1	00010927 1	00010881 1	00010914 1	00010957 1	Verschleißeinlage	wear insert	Blindage	Junta de desgaste
2	7	9	10	12	Schraube	bolt	Vis	Tornillo
3	13	16	19	21	Scheibe	washer	Disque	Arandela
4	7	9	10	12	Scheibe	washer	Disque	Arandela
5	7	9	10	12	Mutter	nut	Écrou	Tuerca
6	6	7	9	9	Schraube	bolt	Vis	Tornillo
7	6	7	9	9	Scheibe	washer	Disque	Arandela
8	6	7	9	9	Mutter	nut	Écrou	Tuerca

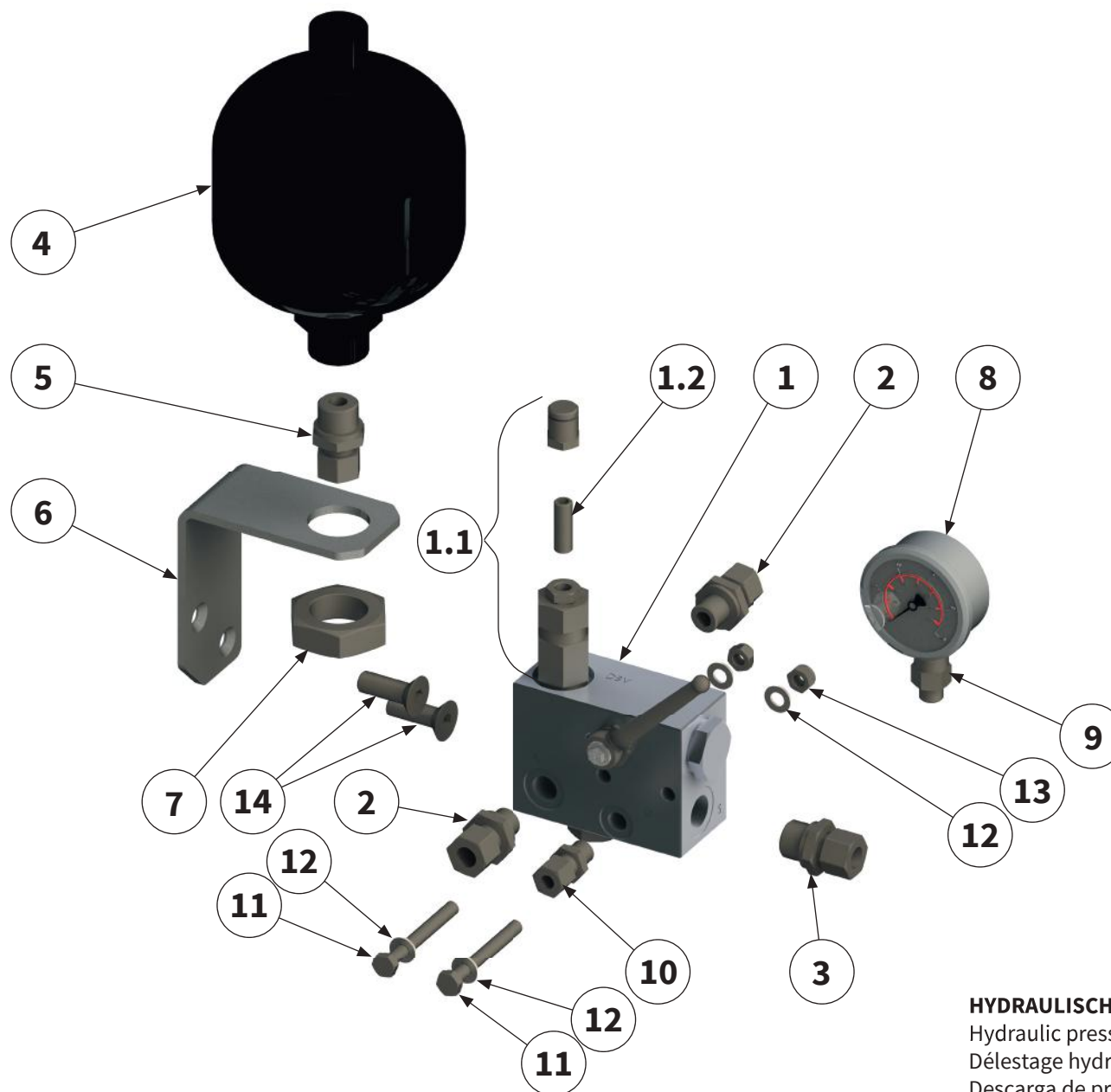

HYDRAULISCHE DRUCKENTLASTUNG MU-SOFA |
 Hydraulic pressure relief MU-SOFA |
 Délestage hydraulique MU-SOFA |
 Descarga de presión hidráulica MU-SOFA |

Pos.-Nr. No. Número	Ersatzteilnummer Manufacturer part number Numéro de pièce du fabricant Número de pieza del fabricante				DE Bezeichnung	EN Designation	FR Désignation	ES Designación
	Anzahl quantity quantité número							
	MU-C 100	MU-C 120	MU-C 140	MU-C 160				
1	1552600				Ventilblock	Valve block	Bloc de soupapes	Bloque de válvulas
	1	1	1	1				
1.1	180352				Ventileinsatz	Valve core	Garniture de s oupape	Inserto de válvula
	1	2	1	1				
1.2	209343				Gewindestift	threaded pin	Tige filetée	Perno roscado
	1	1	1	1				
2	GE-12-PLR-3/8				Verschraubung	Screwed connec- tion	Raccord à vis	Atornillamiento
	2	2	2	2				
3	GE-12-PLR-1/2				Verschraubung	Screwed connec- tion	Raccord à vis	Atornillamiento
	1	1	1	1				
4	209162				Stickstoffspeicher	Nitrogen accumulator	Poche d'azote	Burbuja de nitrógeno
	1	1	1	1				
5	GE-12-PLM 22X1,5				Verschraubung	Screwed connec- tion	Raccord à vis	Atornillamiento
	1	2	1	1				
6	00009033				Haltewinkel	holder	Support	Soporte
	1	1	1	1				
7	00001159				Mutter	nut	Écrou	Tuerca
	1	1	1	1				
8	112922				Manometer	Pressure gauge	Manomètre	Manómetro
	1	1	1	1				
9	MAV-LR08R1/4Zoll				Verschraubung	Screwed connec- tion	Raccord à vis	Atornillamiento
	1	1	1	1				



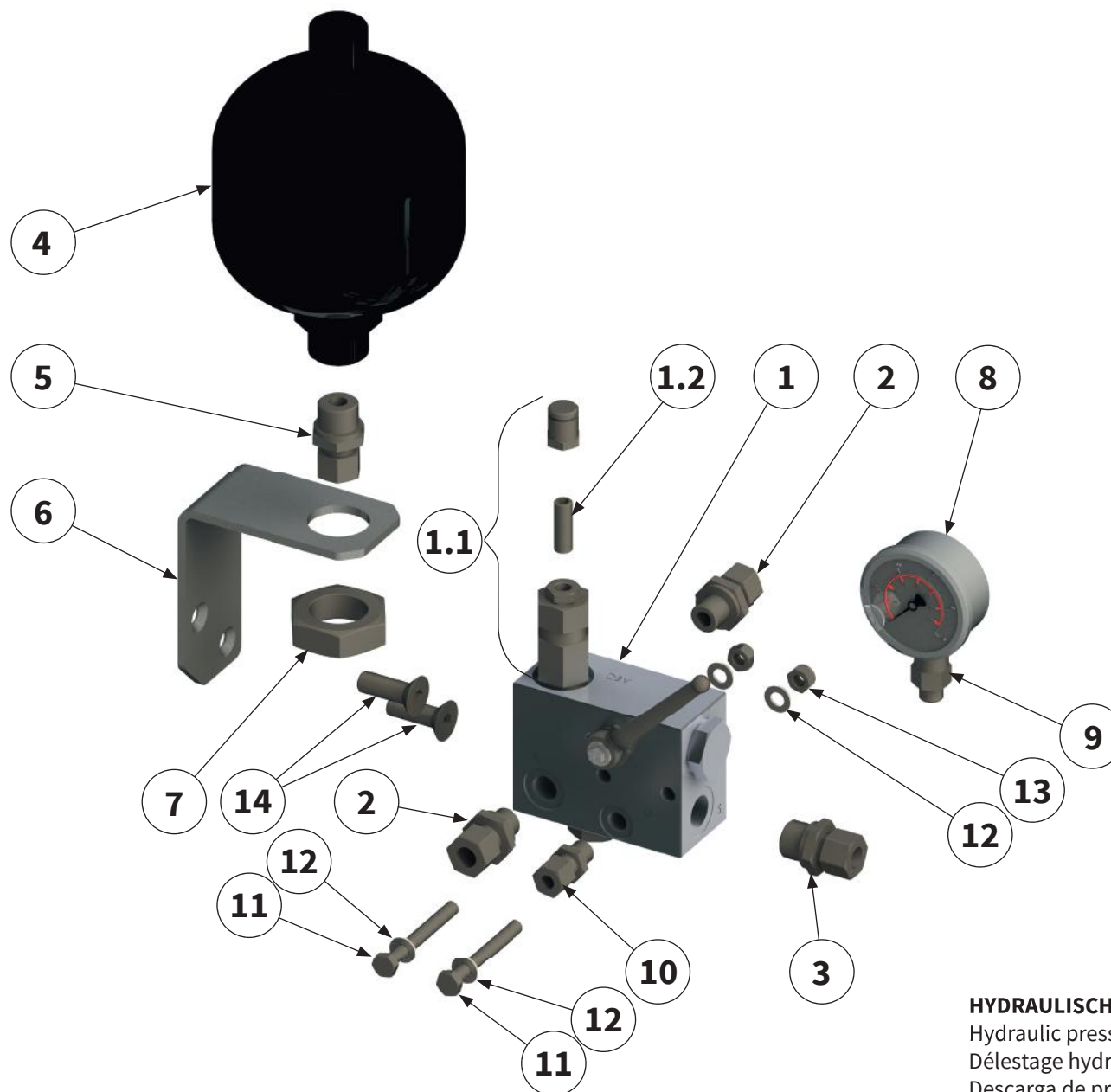

HYDRAULISCHE DRUCKENTLASTUNG MU-SOFA |
 Hydraulic pressure relief MU-SOFA |
 Délestage hydraulique MU-SOFA |
 Descarga de presión hidráulica MU-SOFA |

Pos.-Nr. No. Numéro Número	Ersatzteilnummer Manufacturer part number Numéro de pièce du fabricant Número de pieza del fabricante				DE Bezeichnung	EN Designation	FR Désignation	ES Designación
	Anzahl quantity quantité número							
	MU-C 100	MU-C 120	MU-C 140	MU-C 160				
10	GE-08-PLR-1/4				Verschraubung	Screwed connection	Raccord à vis	Atornillamiento
	1	1	1	1				
11	MU980122				Schraube	bolt	Vis	Tornillo
	2	2	2	2				
12	MU0099999				Scheibe	washer	Disque	Arandela
	6	6	6	6				
13	MU0099961				Mutter	nut	Écrou	Tuerca
	4	4	4	4				
14	MU980134				Schraube	bolt	Vis	Tornillo
	2	2	2	2				

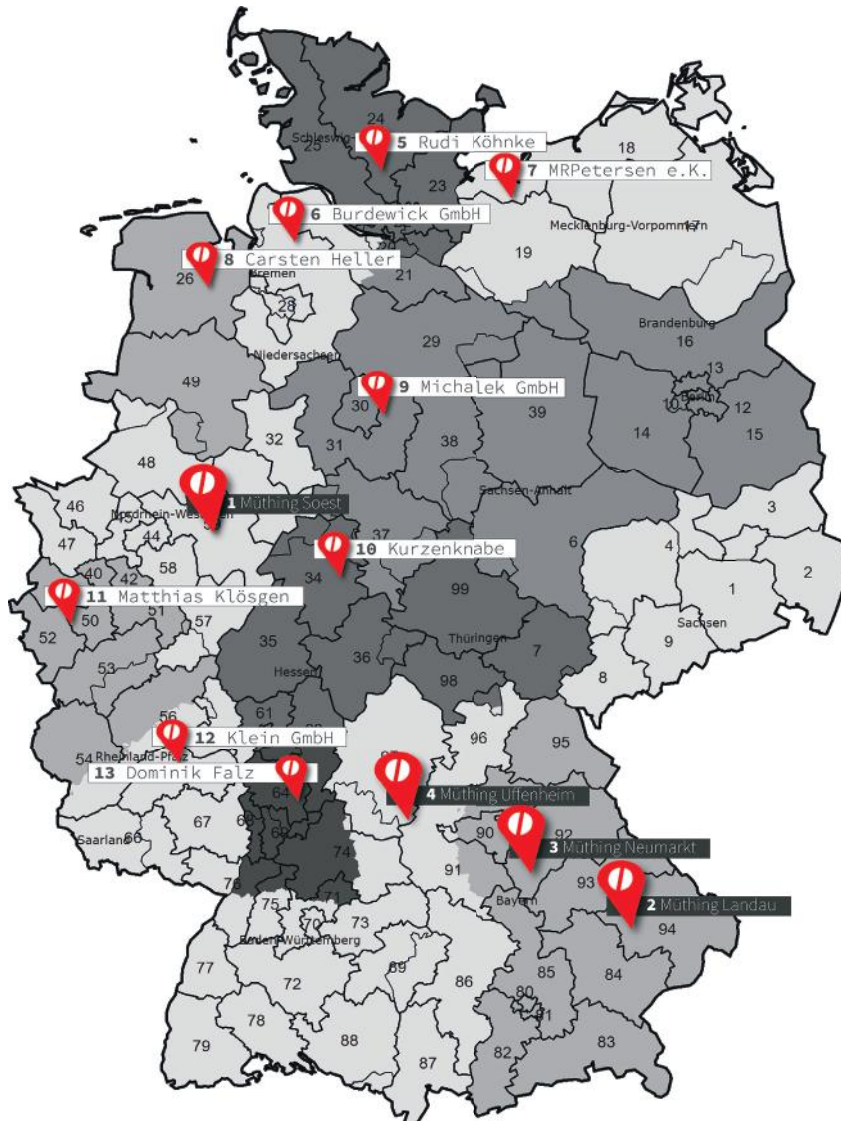

(1) Müthing GmbH & Co. KG Soest

Am Silberg 23
59494 Soest
Tel.: 02921 / 9651 - 0
Fax: 02921 / 73080
E-Mail: et-soest@muething.com

(2) Müthing GmbH & Co. KG Landau

Wiesenweg 6
94405 Landau
Tel.: 09951 / 6908 - 0
Fax: 09951 / 6333
E-Mail: et-landau@muething.com

(3) Müthing GmbH & Co. KG Neumarkt

Hans-Dehn-Str. 7
92318 Neumarkt
Tel.: 09181 / 2976 - 0
Fax: 09181 / 21841
E-Mail: neumarkt@muething.com

(4) Müthing GmbH & Co. KG Uffenheim

Am Brünlein 2
97215 Uffenheim
Tel.: 09842 / 9866 - 0
Fax: 09842 / 9866 - 67
E-Mail: et-uff@muething.com

(5) Rudi Köhnke

Wohldweg 16
24558 Henstedt-Ulzburg
Tel.: 04193 / 91544
Fax: 04193 / 759576
E-Mail: krkoehnke@aol.com

(6) Burdewick GmbH

Mittelstenaher Str. 33
21769 Lamstedt
Tel.: 04773 / 8941 - 0
Fax: 04773 / 8941 - 41
E-Mail: info@burdewick.de

(7) MRPetersen e.K. Werksvertretung

Christiansburger Weg 20
24969 Lindewitt / OT Sillerup
Tel.: 04604 / 9866 - 36
Fax: 04604 / 9866 - 37
E-Mail: rp@mrpetersen.de

(8) Müthing GmbH & Co. KG Soest - Carsten Heller Werksbeauftragter

Tel.: 0160 / 96919245
Fax: 04461 / 759302
E-Mail: c.heller@muething.com

(9) Michalek GmbH

Industriestraße 14
31275 Lehrte
Tel.: 05132 / 2006 - 0
Fax: 05132 / 2006 - 30
E-Mail: info@michalek-ww.de

(10) Kurzenknabe

Obervellmarer Weg 36
34314 Espenau
Tel.: 05673 / 4012
Fax: 05673 / 2495
E-Mail: info@kurzenknabe-gmbh.de

(11) Matthias Klösger

Drovestrasse 104
52372 Kreuzau
Tel.: 02422 / 9019 - 25
Fax: 02422 / 9019 - 26
E-Mail: matthias.kloesger@t-online.de

(12) Klein GmbH

Hauptstraße 2
55627 Weiler / Nahe
Tel.: 06754 / 404
Fax: 06754 / 643
E-Mail: klein-ww-weiler@t-online.de

(13) Dominik Falz

Carl-Benz- Str. 4
64711 Erbach / Odw.
Tel.: 06062 / 1867
Fax: 06062 / 61851
E-Mail: d.falz@muething-mulcher.de

Bei weiteren Fragen zu Technik und Einsatz Ihres Gerätes stehen Ihnen unsere Mitarbeiter oder unsere Vertriebspartner gerne zur Verfügung.

Our employees or sales partners are happy to help should you have any further questions on the technical aspects and use of your implement.

Nos collaborateurs ou nos partenaires commerciaux sont à votre entière disposition pour toutes questions complémentaires relatives aux caractéristiques techniques ou à l'utilisation de votre engin.

Tanto nuestros empleados como los socios comerciales de la marca estamos a su disposición para atender cualquier consulta técnica o sobre piezas que pueda tener respecto a su equipo.

20 horizontal dotted lines for writing.



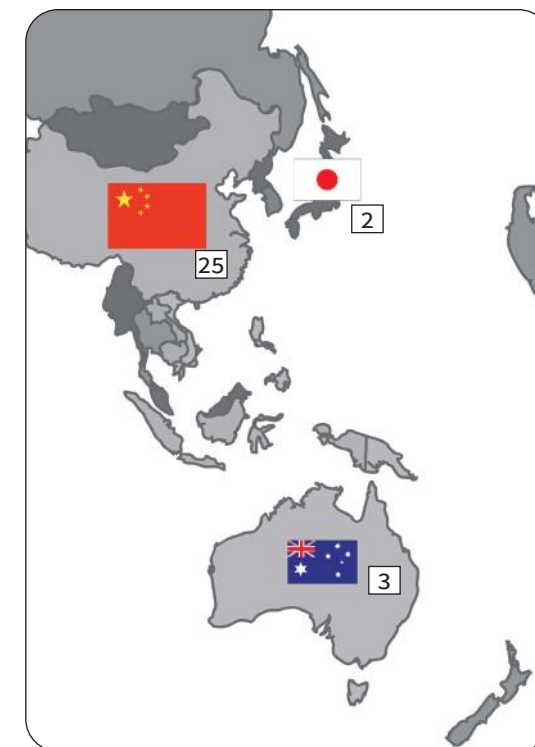



(1) Prairie Agri Sales Ltd.
W. Heidebrecht
P.O Box 216
Road 6W , 26028
Lowe Farm, MB R0G 1E0
Tel.: 001-204-746-6994
Fax: 001-204-515-4064
E-Mail: wheidebrecht@prairiegrisaes.ca



(6) IP Innovations et Paysage
ZI de Saint Nizier
F - 42190 Charlieu
Tel.: 0033 / 477 605454
Fax: 0033 / 477 606846
E-Mail: info@innovex-gmbh.de



(11) Oy J-Trading Ab
Kuriiritie 15
01510 Vantaa
Tel.: 00358 / 207458600
Fax: 00358 / 207458651
E-Mail: info@j-trading.fi



(16) EZ Agrar e. Gen
Salzburger Straße 38
4020 Linz
Tel.: 0043 / 732 347266
Fax: 0043 / 732 347260
E-Mail: office@ezagr.ar.at



(21) Müthing GmbH & Co. KG Soest
Am Silberg 23
59494 Soest
Tel.: 02921 / 9651 -0
Fax: 02921 / 73080
E-Mail: et-soest@muething.com



(2) Agri Direct Co. Ltd.
Higashimemuro, Memuro-cho,
Kasai-gun
18-7 Kita 1-sen
Hokkaido 082-0004
Tel.: 0081 / 155612777
Fax: 0081 / 155612755
E-Mail: info@agridirect.jp



(7) GTJ
Peter Janssen
Way Broek 5
6041PJ Roermond
Tel.: 0031 / 615370411
E-Mail: p.janssen@gjtjtrading.nl



(12) Brøns Group
Hovedvejen 20
6780 Skærbæk
Tel.: 0045 / 74753112
E-Mail: brons@bronsgroup.com



(17) Güttler Mezőgazdasági
Gépgyárto és Szolgá Kft.
Külterület 022/ 35
6800 Hódmezővásárhely
Tel.: 0036 / 62 533690
Fax: 0036 / 62 533691
E-Mail: orsolay.torok@guttler.hu



(22) Müthing GmbH & Co. KG Uffenheim
Am Brunnlein 2
97215 Uffenheim
Tel.: 09842 / 9866 - 0
Fax: 09842 / 9866 - 67
E-Mail: et-uff@muething.com



(3) Southern Cross Mowers PTY Ltd.
Marcus Cornish
1/29 Mustang Drive, PO Box 454
Rutherford NSW Australia 2320
Tel.: 0061 / 240440313
Fax: 0061 / 249321088
E-Mail: mcornish@sxm.com.au



(9) Van Dyke Marcel Belgium
Provinciebaan 71 - 2235 Houtvenne
Tel.: 0032 / 16699156
E-Mail: info@vandyck.be
GÖWEIL BNL PGmbH - Mirfeld
Zur Schmiede 23 - 4770 Amel
E-Mail: office@goeweil.be



(13) Konekesko Eesti AS
Pildiküla Rae vald
Porguvälja tee 3a
75308 Harjumaa MK
Tel.: 00372 / 6059100
Fax: 00372 / 6059101
E-Mail: kristjan.nelis@kesko.ee



(18) Topagri S.r.o.
Kostalkova 1527
26601 Beroun
Tel.: 00420 / 311 636766
Fax: 00420 / 311621822
E-Mail: topagri@topagri.cz



(23) EZ Landmaschinen AG
Bützbergstrasse 70
4912 Aarwangen
Tel.: 0041 / 62 9226801
Fax: 0041 / 62 9230369
E-Mail: info@ezlandmaschinen.ch



(4) Simon Richard Ltd.
Crown Tailrig
Simon Richardt
Bonchester Bridge
Hawick TD9 8RA
Tel.: 0044 / 1450860774
Fax: 0044 / 1450860772
E-Mail: mail@simon-richard.co.uk



(9) Felten Freres et Fils Sarl
Zone Artisanale
9775 Weicherdange
Tel.: 00352 921612
Fax: 00352 920530
E-Mail: info@felten.lu



(14) SIA Konekesko Latvija
Tiraines 15
1058 Riga
Tel.: 00371 / 67064300
Fax: 00371 / 67064301
E-Mail: aivars.metla-rozents@kesko.lv



(19) Ematech s.r.o
Piestanska 3/3
95605 Radosina
Tel.: 00421 / 385398119
Fax: 00421 / 385398216
E-Mail: ematech@ematech.sk



(24) G.I.Antonakis A.E.
3 xlm Thiva-Mouriki
32200 Thiva
Tel.: 0030 / 2262 025915
Fax: 0030 / 2262 025914
E-Mail: gianton@otenet.gr



(5) Delgado Delgado e Hijos, S.A.
C / Sevilla , 23
34004 Palencia
Tel.: 0034 / 979728450
Fax: 0034 / 979710390
E-Mail: recambios@deltacinco.es



(10) ForSentralen AS
Einar M. Bardal/ Carl M. Bardal
Bardalsvegen 100
7724 Steinkjer
Tel.: 0047 / 7414-7600
Fax: 0047 / 7414-9399
E-Mail: forsentralen@online.no



(15) UAB Konekesko
Vilniaus raj.
Moletu g. 13
14262 Didžioji Riese
Tel.: 00370 / 46421752
Fax: 00370 / 46421753
E-Mail: vilnius.sventkauskas@kesko.lt



(20) NHR Agropartners SRL
Judet Ilfov
Calea Bucurestilor 247
075100 Otopeni
Tel.: 0040 / 21 3007906
Fax: 0040 / 213521660
E-Mail: office@vait.ro



(25) Ten Square International Inc. Nanjing
Rm.402 Bldg.2, Zhongqing Plaza NO.96
Caochangmen St. Nanjing, Jiangsu
210013 China
Tel.: 0086 / 25 86210358
Fax: 0086 / 25 86212081
E-Mail: usoffice@tensquareintl.com

A series of horizontal dotted lines spanning the width of the page, intended for writing notes.

20 horizontal dotted lines for writing.





Müthing GmbH & Co. KG Soest
Am Silberberg 23
59494 Soest

Tel +49 (0) 2921 96510
Fax +49 (0) 2921 73080
soest@muething.com

Müthing GmbH & Co. KG Uffenheim
Am Brünlein 2
97215 Uffenheim

Tel +49 (0) 9842 98660
Fax +49 (0) 9842 98667
uffenheim@muething.com

WWW.MUETHING.COM