

ERSATZTEILLISTE | Spare parts list

Liste des pièces de rechange | Lista de repuestos

MU-B-AGRIA 80 - 120

AB SERIE | as of series | á partir de série | desde de la serie 2019

AUSGABE | edition | version | edición 04.2020

ARTIKELNUMMER | article number | número d'article | número de artículo MU-B-AGRIA_ET_19_2020-02

Übertragen Sie hier bitte die Daten Ihres Gerätes und des verwendeten Getriebes.

Enter the details for your implement and the gear box you are using here.

Veuillez inscrire ici les références de votre machine et celles du boîtier.

Introduzca aquí los datos de su equipo y la transmisión utilizada.



*Beispiel Typenschild | Type plate example
Exemple de plaque signalétique | Ejemplo de una placa de características*

Benennung Designation Désignation Designación	Eintrag Entry N° d'enregistrement Registro
Modell Model Modèle Modelo	MU-B-AGRIA 80 - 120 <input type="checkbox"/> 80 <input type="checkbox"/> 100 <input type="checkbox"/> 120
Seriennummer Serial number N° de série Número de serie	
Baujahr Year of manufacture Année de construction Año de construcción	
Getriebetyp Gearbox type Type de Système d'entraînement Tipo de transmisión	
Anbaubock Headstock Attelage Soporte adosado	
Händler Dealer Distributeur Concesionario	
Inbetriebnahme am Commissioning date Date de mise en service Fecha de puesta en servicio	

Bei bitte deutlich ankreuzen !

Where there are checkboxes , please check these clearly!

Veuillez cocher les cases lisiblement!

Por favor, marque con una cruz en la casilla .



Blank page with horizontal dotted lines for writing.



Einleitung Introduction Introduction Introducción	4
Gerätebeschreibung Device description Description de l'appareil Description del dispositivo 	5
Grundausführung Basic model Modèle de base Modelo básico 	
Gehäuse Housing Caisson Caja 	6
Antrieb & Getriebe Drive and gear box Transmission et Système d'entraînement Accionamiento e Cambio 	10
Schäkelrotor Shackle rotor Rotor á manilles Grillete rotor 	16
Stützwalze Support roller Rouleau d'appui Cilindro de apoyo 	20
Getriebe gear box Système d'entraînement Cambio 	24
Sonderzubehör Optional accessory Accessoires optionnels Componentes especiales 	
Frontstützrad Front support wheel Roue d'appui avant Rueda de soporte delantera 	28
Verschleißeinlage Wear insert Blindage Junta de desgaste 	32
Insektenretter Insect rescuer Sauveteur d'insectes Salvador de insectos 	34
Y-Messerrotor Y-blade rotor Y-lame rotor Y-pala de rotor 	36
Kontakte Contacts Contacts Contactos 	
International Internacional Internationale Internationalmente 	39

Handwriting practice area consisting of 20 horizontal dotted lines.



SEHR GEEHRTER KUNDE,

auf den folgenden Seiten finden Sie eine vollständige Übersicht aller Bauteile Ihres Müthing Mulchgerätes MU-B-AGRIA 80 - 120. Anhand dieser Unterlage bitten wir Sie benötigte Ersatzteile genau zu identifizieren und mit den nachfolgenden Angaben zu bestellen. Benötigen Sie Hilfe oder weitere Informationen kontaktieren Sie uns.

Vielen Dank - Ihr Müthing-Team

CHER CLIENT,

Vous trouverez sur les pages suivantes une description complète des composants de votre broyeur Müthing MU-B-AGRIA 80 - 120. Nous vous invitons à identifier exactement les pièces de rechange requises à l'appui de ce document et de les commander en indiquant le n° de référence de pièces de rechange. N'hésitez pas à nous contacter si vous avez besoin d'aide ou d'informations complémentaires.

Merci beaucoup – Votre équipe Müthing

DEAR CUSTOMER,

The following pages offer a complete overview of the components in your Müthing MU-B-AGRIA 80 - 120 mulcher. We are providing you with this document so that you can identify exactly the spare parts you require and order them using the spare part numbers listed. Should you need any assistance or further information, please contact us.

Kind regards - Your Müthing team

ESTIMADO CLIENTE,

En las siguientes páginas ponemos a su disposición una relación completa de los componentes de su trituradora MU-B-AGRIA 80 - 120 de Müthing. Le rogamos que con ayuda de este listado identifique las piezas de repuesto necesarias y las encargue con su correspondiente número de repuesto. No dude en ponerse en contacto con nosotros para solicitar ayuda o información ampliada.

Muchas gracias - Su equipo Müthing



Beachten Sie immer die Sicherheitshinweise der Betriebsanleitung !

Always follow the safety instructions in the operating manual.

Veuillez toujours tenir compte des consignes de sécurité figurant dans le manuel d'utilisation !

Observe siempre las indicaciones de seguridad de las instrucciones de servicio !

DIE HAUPTBAUGRUPPEN SIND:

1. Mulchergehäuse mit Schutzlamellen, hinterem Gummischutz und Gleitkufen
2. Rotor mit Lagerung, Werkzeugen und Werkzeughaltern
3. Stützwalze (Stützräder) mit Lagerung
4. Keilriemenantrieb mit Keilriemenschutzhaube
5. Getriebe
6. Sonderzubehör

THE MAIN COMPONENTS ARE:

1. Mulcher housing with protective strips, rear rubber protector and skids
2. Rotor with mount, tools and tool holders
3. Support roller (support wheels) with mount
4. V-belt drive with V-belt guard
5. Gear box
6. Optional accessories



LES GROUPES PRINCIPAUX SONT:

1. Carter du broyeur avec lamelles de protection, protection en caoutchouc à l'arrière et patins de glissement
2. Rotor équilibré avec outils et supports d'outils
3. Rouleau d'appui (roues supports) avec suspension
4. Transmission par courroie trapézoïdale avec capot de protection
5. Système d'entraînement
6. Accessoires spécifiques

LOS GRUPOS CONSTRUCTIVOS PRINCIPALES SON:

1. Carcasa de la trituradora con placas de protección, protección trasera de goma y patines
2. Rotor con cojinete, herramientas y portaherramientas
3. Cilindro de apoyo (ruedas de apoyo) con cojinete
4. Accionamiento por correa trapezoidal con cubierta protectora de la correa
5. Transmisión
6. Accesorio especial

| Hauptbaugruppe Schlegelmulcher Baureihe MU-B-AGRIA 80 - 120
| Main assembly of the MU-B-AGRIA 80 - 120 flail mulcher
| Groupe principal Broyeur à marteaux série MU-B-AGRIA 80 - 120
| Grupo constructivo desbrozadora serie MU-B-AGRIA 80 - 120

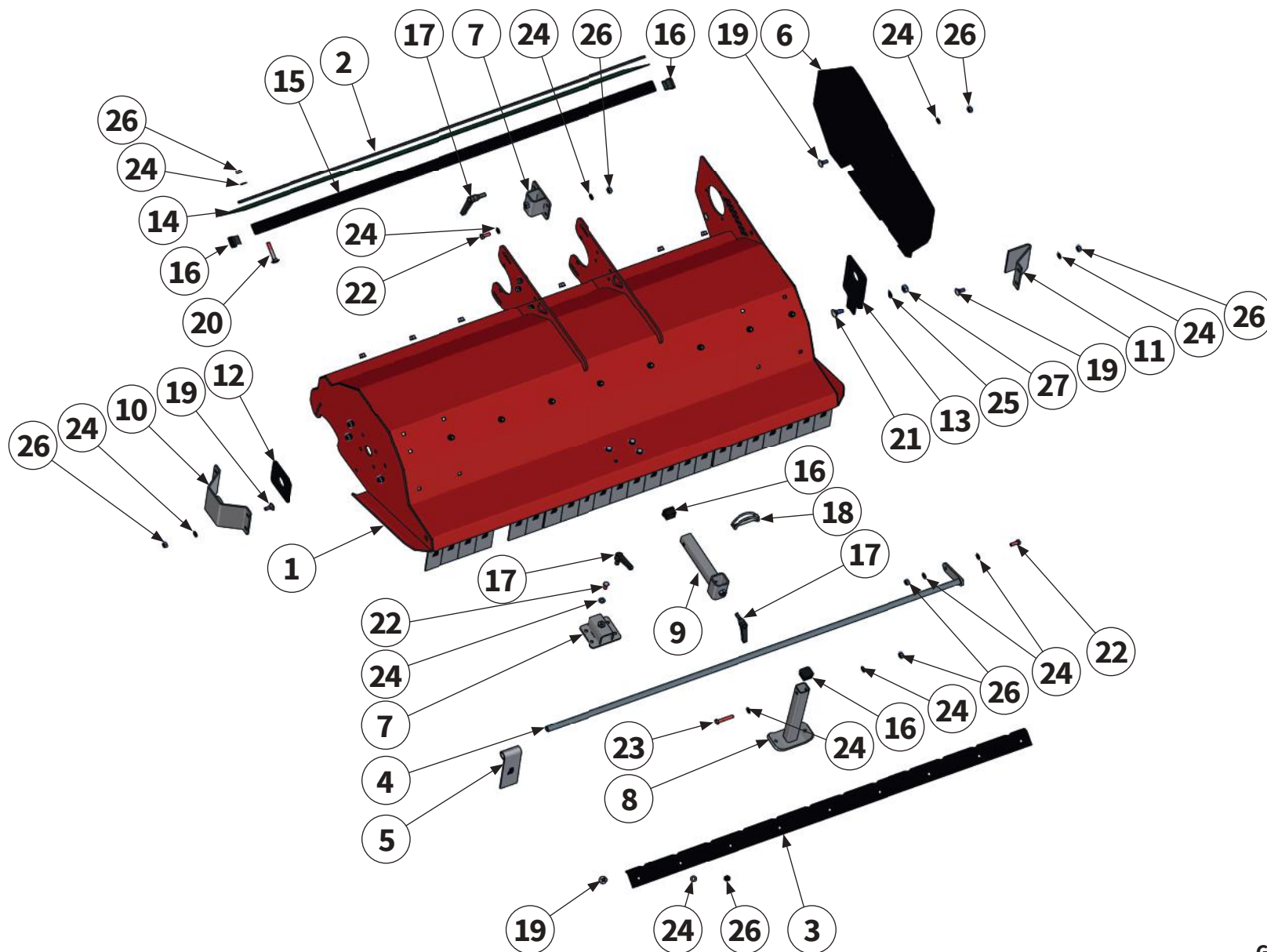

Pos.-Nr. No. Número	Ersatzteilnummer Manufacturer part number Numéro de pièce du fabricant Número de pieza del fabricante			DE Bezeichnung	EN Designation	FR Désignation	ES Designación
	Anzahl quantity quantité número						
	MU-B AGRIA 80	MU-B AGRIA 100	MU-B AGRIA 120				
1	00019565 1	00019562 1	00019524 1	Gehäuse	housing	Caisson	Caja
2	00005499 1	00005493 1	00003529 1	Klemmleiste	support plate	Tôle de support	Chapa de retención
3	00019637 1	00019636 1	00019635 1	Gegenschneide	short-chopping bar	Lame hache-paille courte	Listón de corte de paja corto
4	00005523 1	00001295 1	00001124 1	Pendelwelle	swing shaft	Arbre oscillant	Eje del péndulo
5	16	MU0501131 20	24	Pendelschutz- klappe	flap with swing protection	Volet de protection oscillant	Tapa protectora del péndulo
6	1	00019526 1	1	Schutzabdeckung	protective cover	Recouvrement de protection	Cubierta protectora
7	2	00001134 2	2	Halter	holder	Support	Soporte
8	1	00001101 1	1	Abstellstütze	support leg	Béquille de stationnement	Pie de apoyo
9	1	00001137 1	1	Halter	holder	Support	Soporte
10	1	00015374 1	1	Abweiser	deflector	Défecteur	Deflector
11	1	00001130 1	1	Schutz	guard	Protection	Protección
12	1	00001119 1	1	Lagerflansch	flange	Bride	Brida
13	1	00001120 1	1	Lagerflansch links	flange left	Bride gauche	Brida izquierda



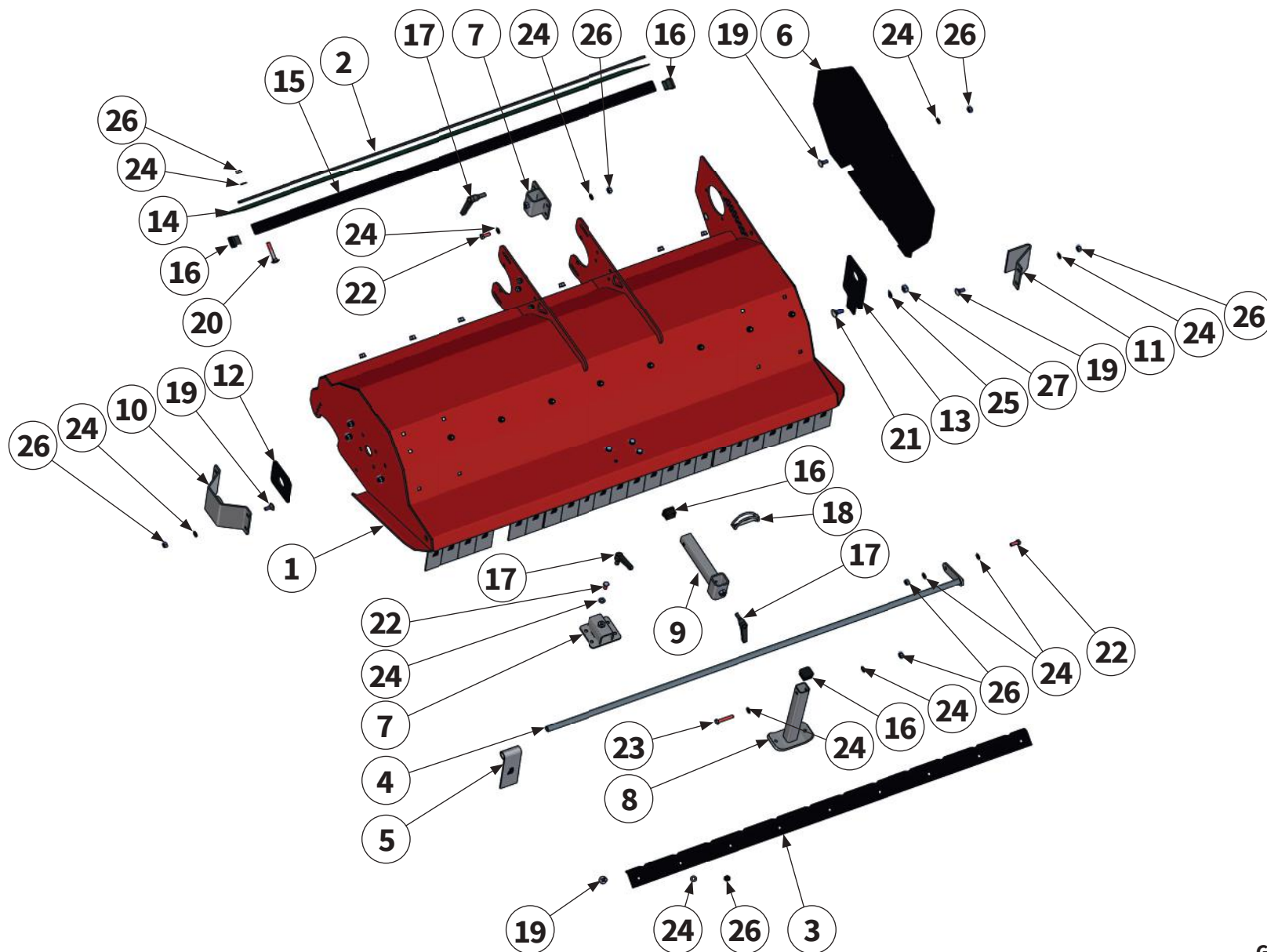

Pos.-Nr. No. Numéro Número	Ersatzteilnummer Manufacturer part number Numéro de pièce du fabricant Número de pieza del fabricante			DE Bezeichnung	EN Designation	FR Désignation	ES Designación
	Anzahl quantity quantité número						
	MU-B AGRIA 80	MU-B AGRIA 100	MU-B AGRIA 120				
14	00019693 1	00019694 1	00019696 1	Schutztuch	protective cloth	Tissu de protection	Tela protectora
15	00019692 1	00019695 1	00019697 1	Profilrohr	section tube	tube de section	tubo de perfil
16		00003433 4		Verschlußstopfen	sealing plug	Bouchon de fermeture	Tapón de cierre
17		00015825 3		Klemmhebel	clamping lever	Levier de serrage	Palanca de sujeción
18		00005605 1		Splint	split pin	Goupille fendue	Pasador de aletas
19		MU980107 17		Schraube	bolt	Vis	Tornillo
20		MU981164 9		Schraube	bolt	Vis	Tornillo
21		00000903 2		Schraube	bolt	Vis	Tornillo
22		MU980115 9		Schraube	bolt	Vis	Tornillo
23		MU0099909 1		Schraube	bolt	Vis	Tornillo
24		MU0099999 41		Scheibe	washer	Disque	Arandela
25		MU980202 2		Scheibe	washer	Disque	Arandela
26		MU0099961 31		Mutter	nut	Écrou	Tuerca
27		MU0099960 2		Mutter	nut	Écrou	Tuerca

Eine detaillierte Explosionsskizze des Getriebes finden Sie auf den folgenden Seiten.

A detailed exploded view of the gear box can be found on the following pages.

Vous trouverez un schéma éclaté détaillé du boîtier sur les pages suivantes.

En las siguientes páginas también se incluye un diagrama de vista explotada de la transmisión.

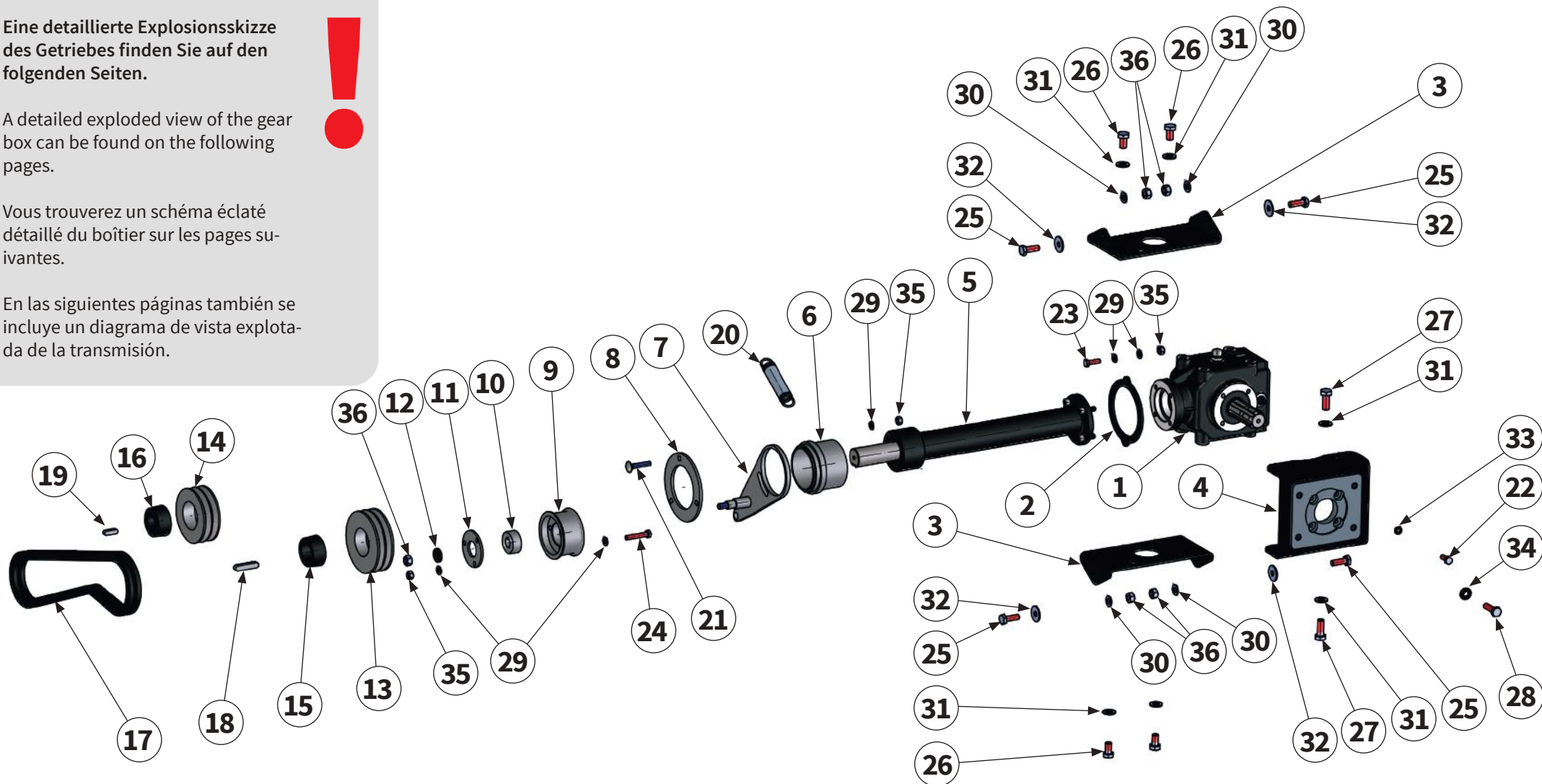

Pos.-Nr. No. Número	Ersatzteilnummer Manufacturer part number Numéro de pièce du fabricant Número de pieza del fabricante			DE Bezeichnung	EN Designation	FR Désignation	ES Designación
	Anzahl quantity quantité número						
	MU-B AGRIA 80	MU-B AGRIA 100	MU-B AGRIA 120				
1	1	00019545 1	1	Getriebe	gear box	Système d'entraînement	Caja de cambios
2	1	00001095 1	1	Zentrierring	centering	Centrage	Centrado
3	2	00001075 2	2	Getriebehalter	gear box holder	Support de transmission	Soporte del cambio
4	1	00019612 1	1	Momentenstütze	torque support	Support de couple	Apoyo de par
5	MU280400 1	MU280440 1	MU2000520 1	Getriebeverlängerung	extension shaft	Arbre de rallonge	Eje de prolongación
6	1	00001078 1	1	Buchse	bush	Douille	Casquillo
7	1	00001091 1	1	Spannvorrichtung	clamping device	Dispositif de serrage	Dispositivo de sujeción
8	1	00001076 1	1	Haltescheibe	retaining washer	Rondelle de retenue	Arandela de retención
9	1	00001092 1	1	Spannrolle	idler pulley	Galet tendeur	Rodillo tensor
10	1	00001097 1	1	Wälzlager	roller bearing	Palier à roulement	Rodamientos
11	1	00001073 1	1	Flansch	flange	Bride	Brida
12	1	00001088 1	1	Scheibe	washer	Disque	Arandela



Eine detaillierte Explosionsskizze des Getriebes finden Sie auf den folgenden Seiten.

A detailed exploded view of the gear box can be found on the following pages.

Vous trouverez un schéma éclaté détaillé du boîtier sur les pages suivantes.

En las siguientes páginas también se incluye un diagrama de vista explotada de la transmisión.

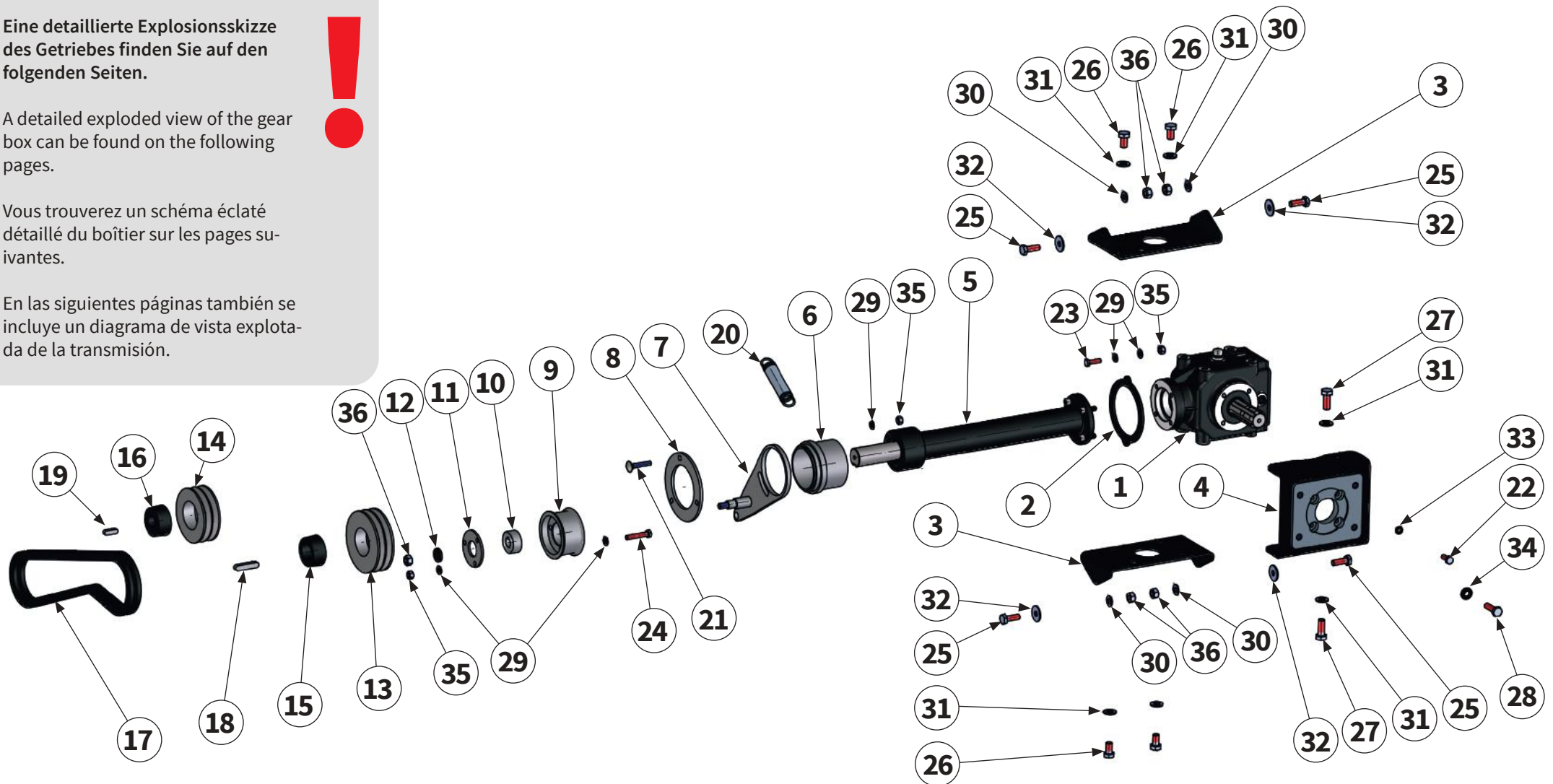

Pos.-Nr. No. Número	Ersatzteilnummer Manufacturer part number Numéro de pièce du fabricant Número de pieza del fabricante			DE Bezeichnung	EN Designation	FR Désignation	ES Designación
	Anzahl quantity quantité número						
	MU-B AGRIA 80	MU-B AGRIA 100	MU-B AGRIA 120				
13	1	00001086 1	1	Keilriemenscheibe	V-belt pulley	Poulie	Polea
14	1	00001087 1	1	Keilriemenscheibe	V-belt pulley	Poulie	Polea
15	1	00001093 1	1	Spannbuchse	clamping bush	Douille de serrage	Manguito de sujeción
16	1	MU981805 1	1	Spannbuchse	clamping bush	Douille de serrage	Manguito de sujeción
17	2	00001077 2	2	Keilriemen	V-belt	Courroie trapézoïdale	Correa trapezoidal
18	1	00001084 1	1	Paßfeder	parallel key	Clavette	Chaveta de ajuste
19	1	00001085 1	1	Paßfeder	parallel key	Clavette	Chaveta de ajuste
20	1	00001096 1	1	Zugfeder	tension spring	Ressort de traction	Resorte de tracción
21	3	MU981256 3	3	Schraube	bolt	Vis	Tornillo
22	4	MU980115 4	4	Schraube	bolt	Vis	Tornillo
23	2	MU980109 2	2	Schraube	bolt	Vis	Tornillo
24	3	MU0099909 3	3	Schraube	bolt	Vis	Tornillo
25	4	MU980205 4	4	Schraube	bolt	Vis	Tornillo

Eine detaillierte Explosionsskizze des Getriebes finden Sie auf den folgenden Seiten.

A detailed exploded view of the gear box can be found on the following pages.

Vous trouverez un schéma éclaté détaillé du boîtier sur les pages suivantes.

En las siguientes páginas también se incluye un diagrama de vista explotada de la transmisión.

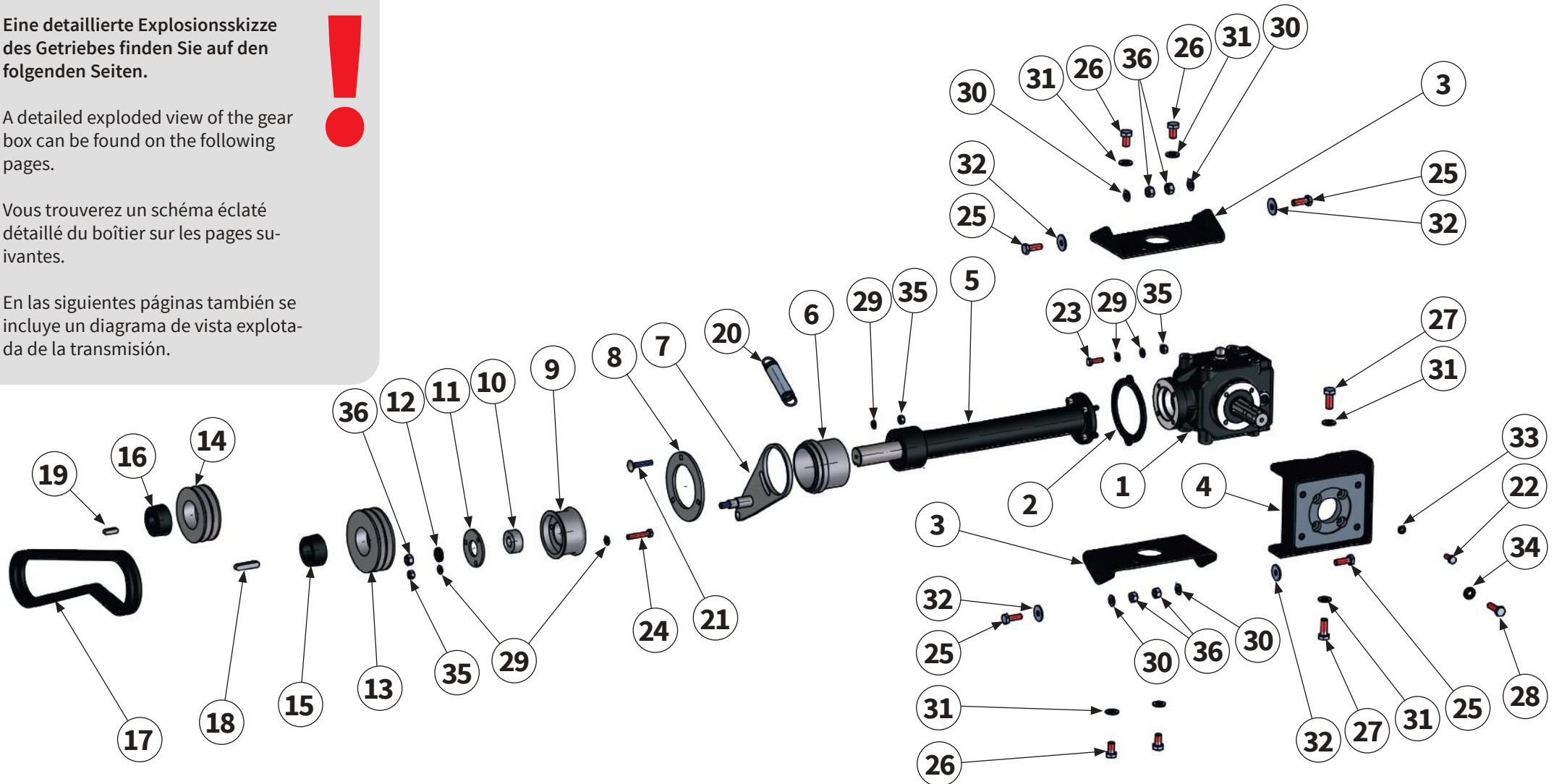

Pos.-Nr. No. Número	Ersatzteilnummer Manufacturer part number Numéro de pièce du fabricant Número de pieza del fabricante			DE Bezeichnung	EN Designation	FR Désignation	ES Designación
	Anzahl quantity quantité número						
	MU-B AGRIA 80	MU-B AGRIA 100	MU-B AGRIA 120				
26	4	MU980335 4	4	Schraube	bolt	Vis	Tornillo
27	4	MU980307 4	4	Schraube	bolt	Vis	Tornillo
28	4	MU980311 4	4	Schraube	bolt	Vis	Tornillo
29	13	MU0099999 13	13	Scheibe	washer	Disque	Arandela
30	4	MU980202 4	4	Scheibe	washer	Disque	Arandela
31	8	MU980302 8	8	Scheibe	washer	Disque	Arandela
32	4	MU0099950 4	4	Scheibe	washer	Disque	Arandela
33	4	MUNL0008 4	4	Scheibe	washer	Disque	Arandela
34	4	MUNSKL10 4	4	Scheibe	washer	Disque	Arandela
35	8	MU0099961 8	8	Mutter	nut	Écrou	Tuerca
36	5	MU0099960 5	5	Mutter	nut	Écrou	Tuerca



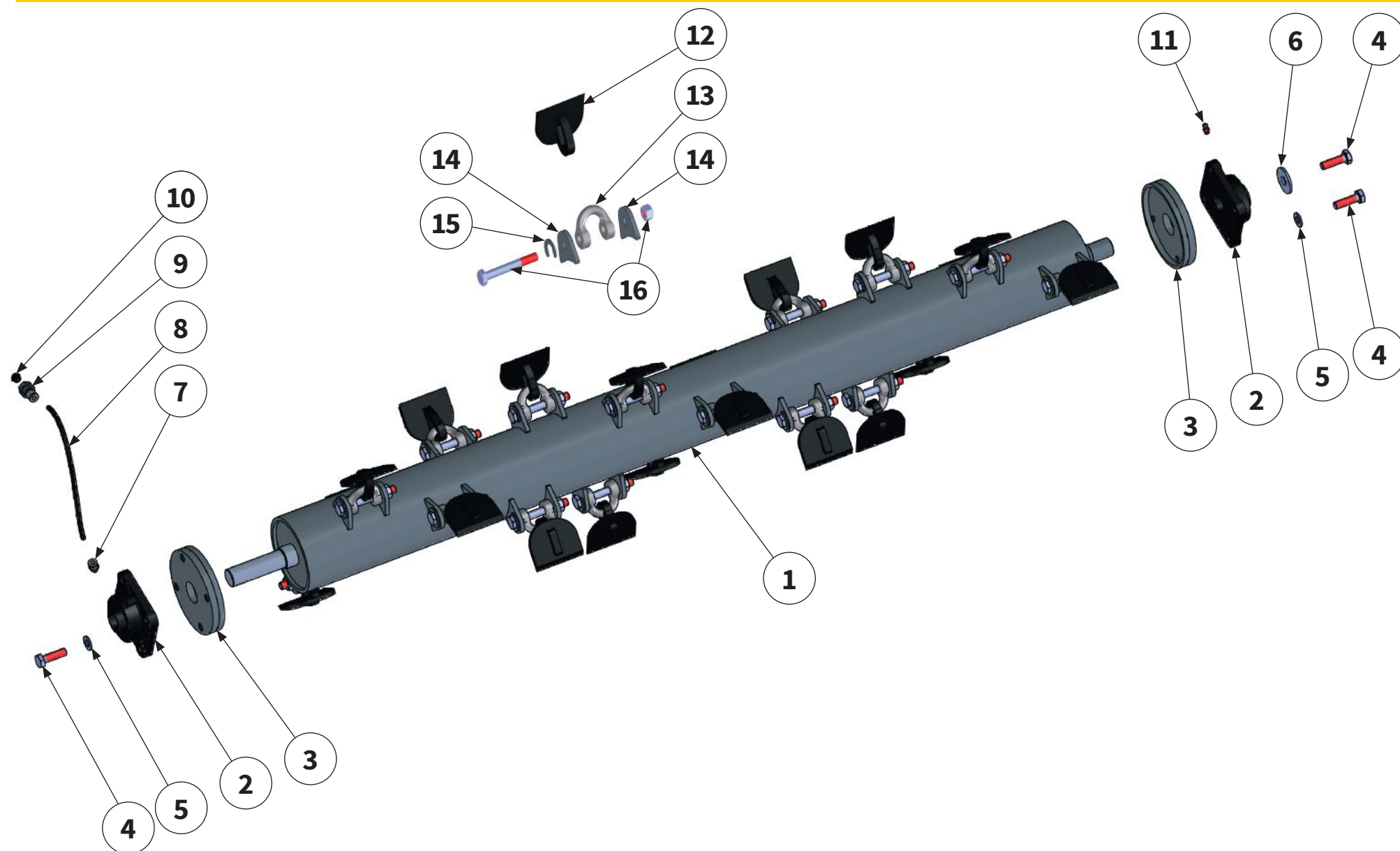

Pos.-Nr. No. Número	Ersatzteilnummer Manufacturer part number Numéro de pièce du fabricant Número de pieza del fabricante			DE Bezeichnung	EN Designation	FR Désignation	ES Designación
	Anzahl quantity quantité número						
	MU-B AGRIA 80	MU-B AGRIA 100	MU-B AGRIA 120				
1	MU5040011 1	MU5040021 1	MU5040031 1	Rotor inkl. Werkzeug	rotor with tools	Rotor avec outils	Rotor con herram
2	2	MU0501041 2	2	Flanschlager	rotor holder	Support de Rotor	Soporte del Rotor
3	2	MU5102211 2	2	Wickelschutz	anti-wrapping device	Protection contre l'enroulement	Protección enrolla- ble
4	9	MU980205 9	9	Schraube	bolt	Vis	Tornillo
5	8	MU980202 8	8	Scheibe	washer	Disque	Arandela
6	1	MU980203 1	1	Scheibe	washer	Disque	Arandela
7	0,17 m	MULI0005 0,17 m	0,17 m	Schmierleitung	lubrication line	Conduite de graissage	Tubería de engrase
8	1	MULI0001 1	1	Verschraubung	Screwed connection	Raccord à vis	Atornillamiento
9	1	MULI0003 1	1	Verschraubung	Screwed connection	Raccord à vis	Atornillamiento
10	1	MULI0004 1	1	Schmiernippel	lubricating nipple	Nipple de graissage	Engrasador
11	1	DIN71412A-H1-M06x1 1	1	Schmiernippel	lubricating nipple	Nipple de graissage	Engrasador
12	12	MU5 16	20	Schäkelmesser	shackle flail	Lame de manille	Chuchilla del grillete
13	12	MU0801031 16	20	Schäkel	shackle	Manille	Grillete

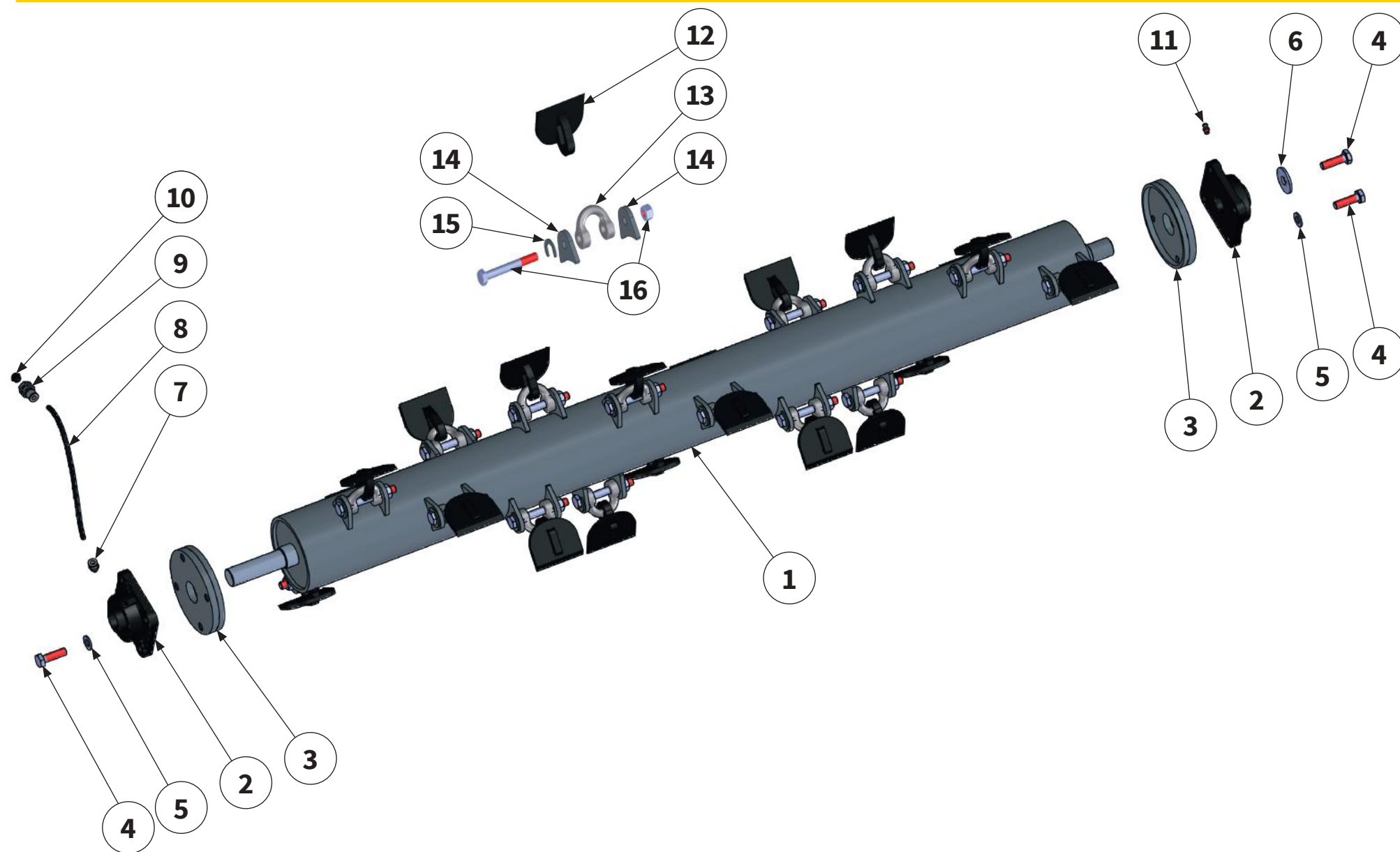

Pos.-Nr. No. Numéro Número	Ersatzteilnummer Manufacturer part number Numéro de pièce du fabricant Número de pieza del fabricante			DE Bezeichnung	EN Designation	FR Désignation	ES Designación
	Anzahl quantity quantité número						
	MU-B AGRIA 80	MU-B AGRIA 100	MU-B AGRIA 120				
14	MU0504101			Werkzeughalter	tool holders	Porte-outils	portaherramientas
	24	32	40				
15	MU0702051			Verdrehsicherung	anti-twist protection	Sécurité anti-torsion	Seguro contra giro
	12	16	20				
16	MU0801041			Schraube mit Mutter	bolt with nut	Vis avec Écrou	Tornillo con Tuerca
	12	16	20				



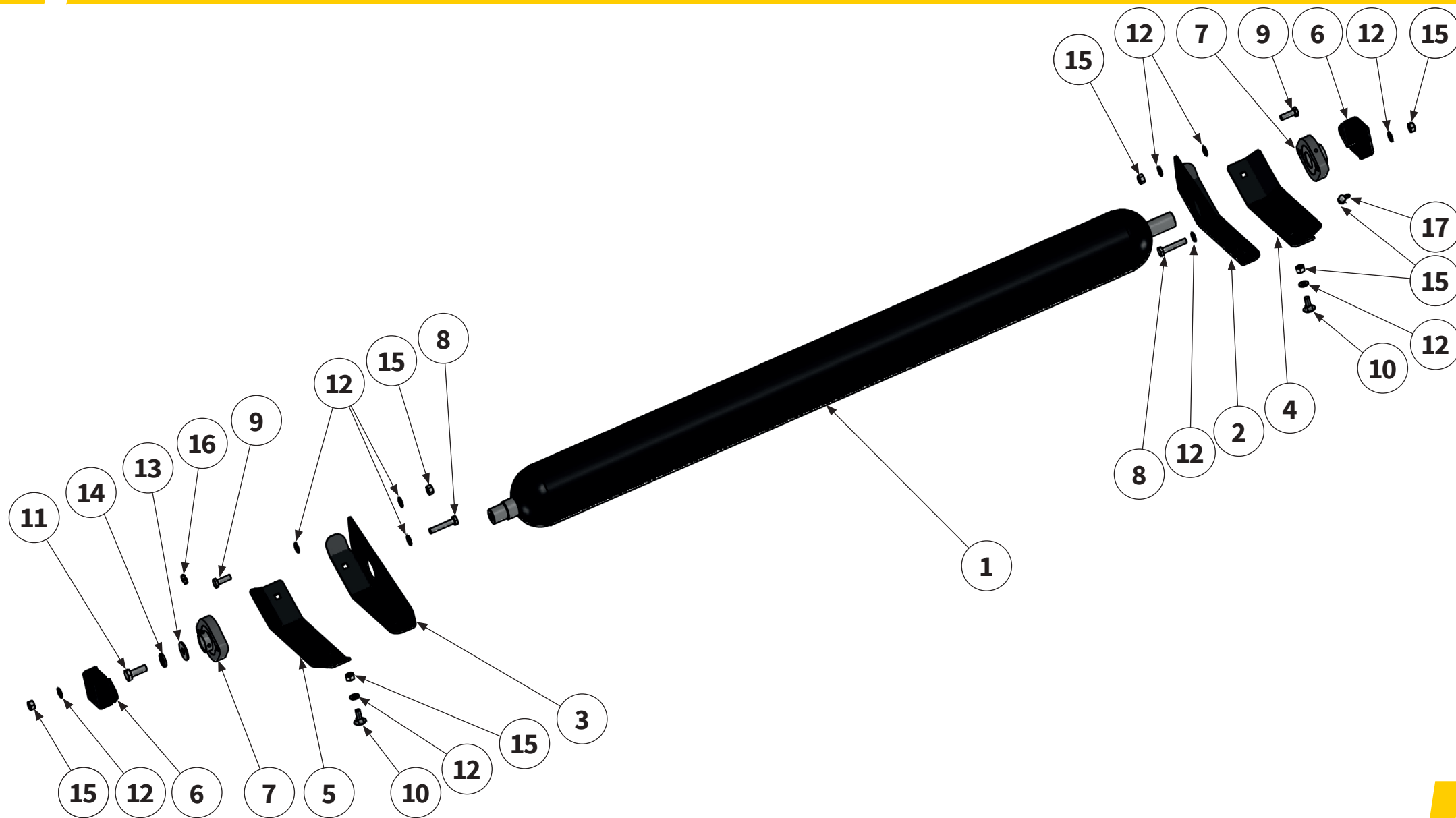

Pos.-Nr. No. Número	2Ersatzteilnummer Manufacturer part number Numéro de pièce du fabricant Número de pieza del fabricante			DE Bezeichnung	EN Designation	FR Désignation	ES Designación
	Anzahl quantity quantité número						
	MU-B AGRIA 80	MU-B AGRIA 100	MU-B AGRIA 120				
1	MU1509001 1	MU1509002 1	MU1509003 1	Stützwalze	support roller	Rouleau d'appui	Cilindro de apoyo
2	1	00001138 1	1	Halteplatte links	retainer plate left	Plaque de support gauche	Placa de retención izquierda
3	1	00001139 1	1	Halteplatte rechts	retainer plate right	Plaque de support droite	Placa de retención derecha
4	1	00003515 1	1	Verschleißkufe links	wear runner left	Patin d'usure gauche	Cuchilla de desgaste izquierda
5	1	00003516 1	1	Verschleißkufe rechts	wear runner right	Patin d'usure droite	Cuchilla de desgaste derecha
6	2	MU0227210 2	2	Abdeckung	cover	Recouvrement	Cubierta
7	2	MU0501051 2	2	Flanschlager	flange bearing	Palier	Teniendo
8	4	MU0099909 4	4	Schraube	bolt	Vis	Tornillo
9	6	MU980109 6	6	Schraube	bolt	Vis	Tornillo
10	4	MU980107 4	4	Schraube	bolt	Vis	Tornillo
11	1	MU980205 1	1	Schraube	bolt	Vis	Tornillo
12	24	MU0099999 24	24	Scheibe	washer	Disque	Arandela



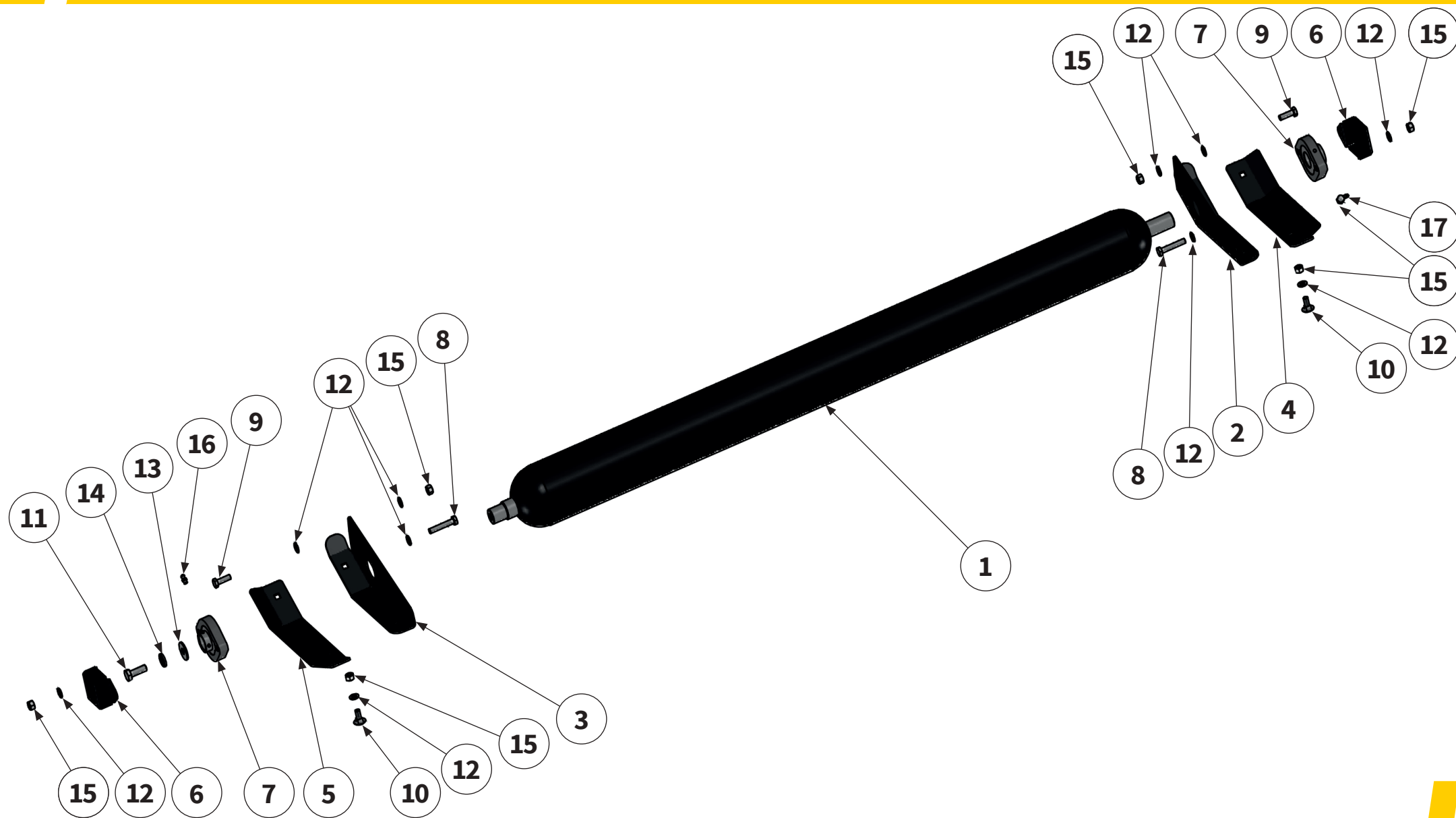

Pos.-Nr. No. Numéro Número	Ersatzteilnummer Manufacturer part number Numéro de pièce du fabricant Número de pieza del fabricante			DE Bezeichnung	EN Designation	FR Désignation	ES Designación
	Anzahl quantity quantité número						
	MU-B AGRIA 80	MU-B AGRIA 100	MU-B AGRIA 120				
13	MU0099950			Scheibe	washer	Disque	Arandela
	1	1	1				
14	MUNSKL10			Scheibe	washer	Disque	Arandela
	1	1	1				
15	MU0099960			Mutter	nut	Écrou	Tuerca
	14	14	14				
16	DIN71412A-H1-M06x1			Schmiernippel	lubricating nipple	Nipple de graissage	Engrasador
	1	1	1				
17	DIN71412C-H3 M06x1			Schmiernippel	lubricating nipple	Nipple de graissage	Engrasador
	1	1	1				



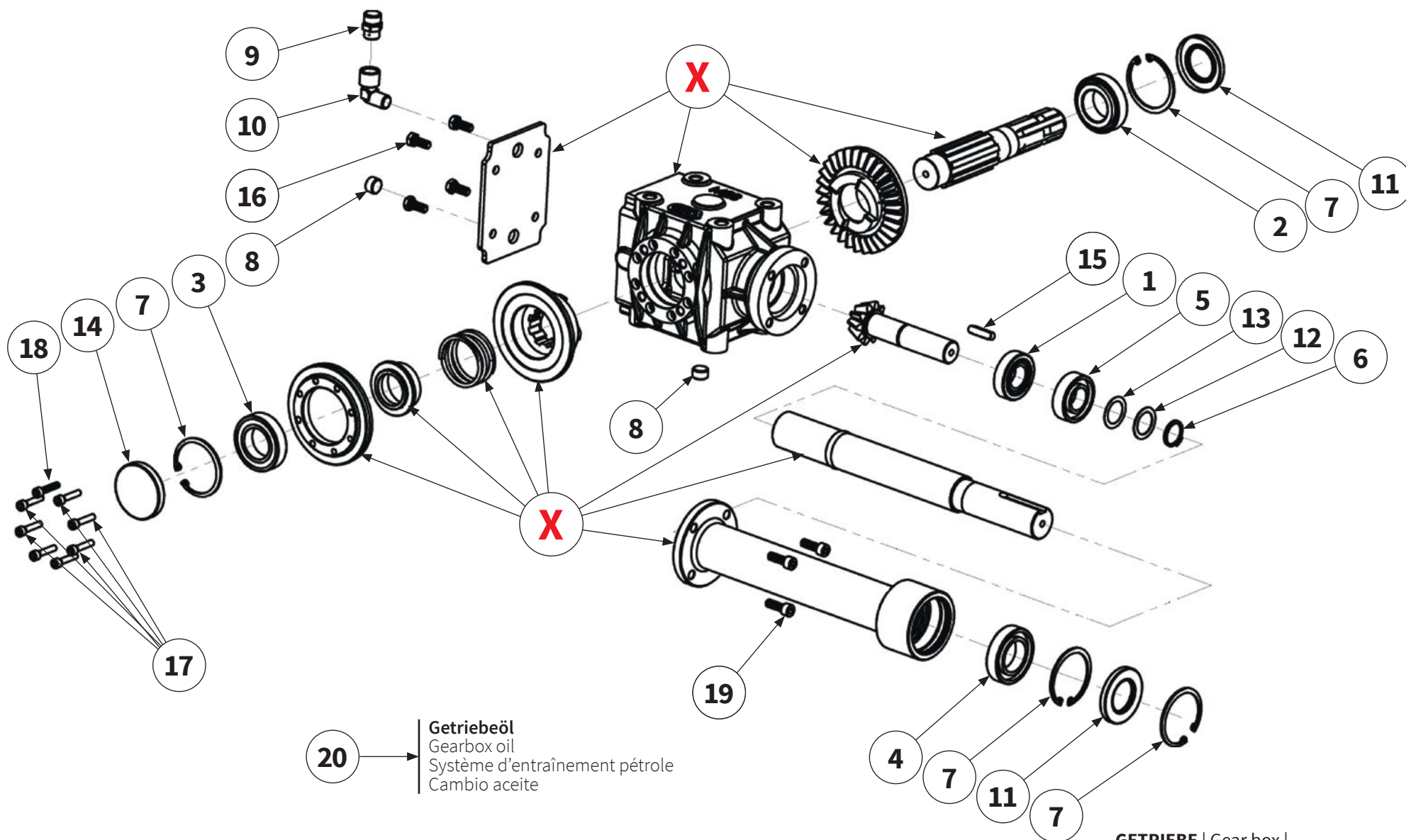

20 → **Getriebeöl**
 Gearbox oil
 Système d'entraînement pétrole
 Cambio aceite

Pos.-Nr. No. Número	Ersatzteilnummer Manufacturer part number Numéro de pièce du fabricant Número de pieza del fabricante			DE Bezeichnung	EN Designation	FR Désignation	ES Designación
	Anzahl quantity quantité número						
	MU-B AGRIA 80	MU-B AGRIA 100	MU-B AGRIA 120				
1	1	MU280006 1	1	Lager	bearing	Palier	Cojinete
2	1	MUR20217 1	1	Lager	bearing	Palier	Cojinete
3	1	MU280008 1	1	Lager	bearing	Palier	Cojinete
4	1	MUR20216 1	1	Lager	bearing	Palier	Cojinete
5	1	MU280010 1	1	Lager	bearing	Palier	Cojinete
6	1	MU280012 1	1	Sicherungsring	circlip	Bague de sécurité	Anillo de seguridad
7	4	MU7T1025 4	4	Sicherungsring	circlip	Bague de sécurité	Anillo de seguridad
8	3	MU623017 3	3	Ablass- kontrollschraube	bolt	Vis	Tornillo
9	1	MU623018 1	1	Getriebeentlüftung	gearbox breather	Boîte de vitesses reniflard	Respiradero de la caja de cambios
10	1	MU280019 1	1	Verschraubung	Screwed connection	Raccord à vis	Atornillamiento
11	2	MUR20204 2	2	Wellendichtring	shaft seal	Baque d'levre	Retén de eye
12	1	MU280024 1	1	Distanzscheibe	spacer	Disque d'écartement	Arandela distanciadora
X	Teile einzeln vom Hersteller nicht lieferbar Parts from the manufacturer cannot be supplied individually Pièces non livrables séparément par le fabricant El fabricante no suministra piezas individuales						

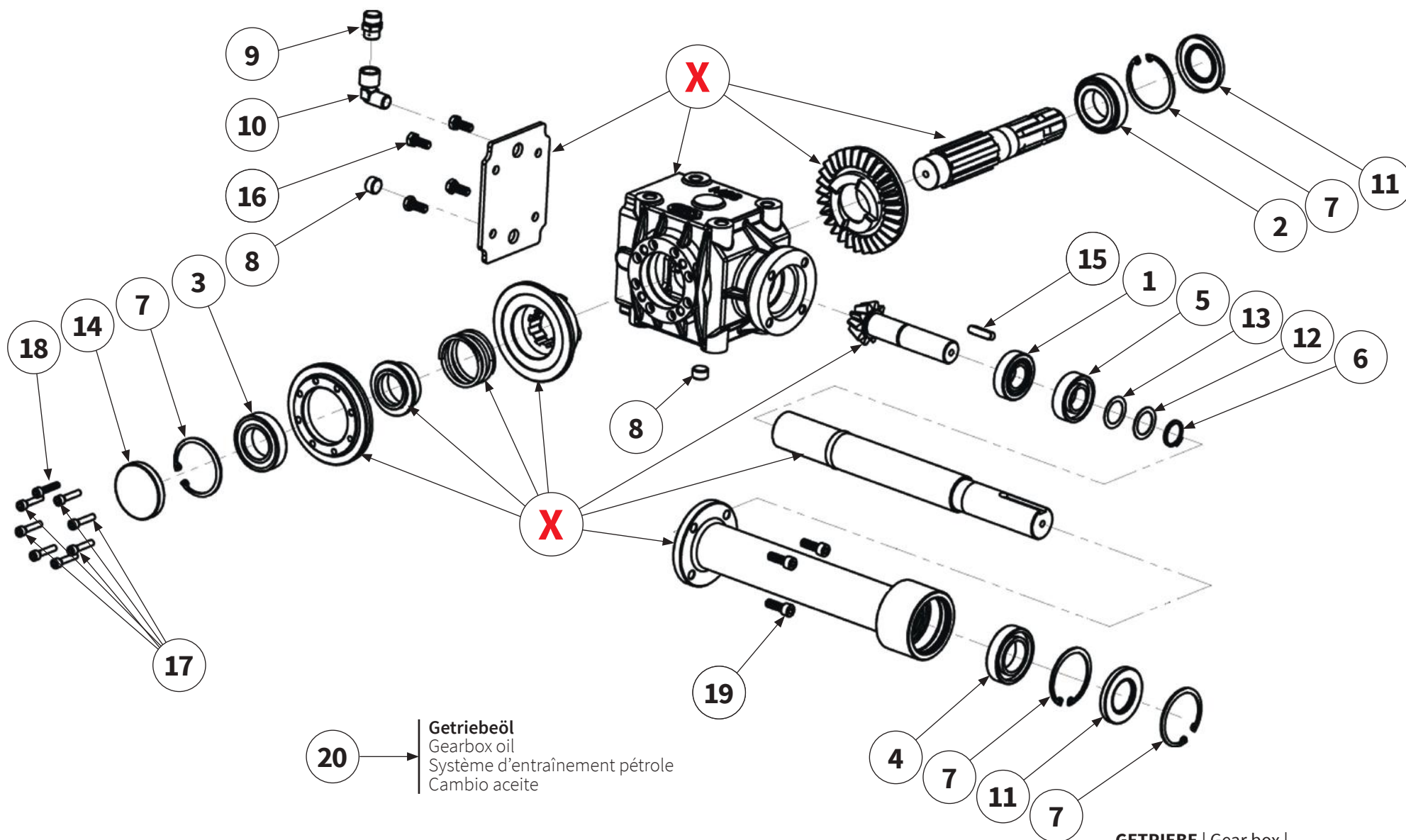

20 → **Getriebeöl**
 Gearbox oil
 Système d'entraînement pétrole
 Cambio aceite

Pos.-Nr. No. Número	Ersatzteilnummer Manufacturer part number Numéro de pièce du fabricant Número de pieza del fabricante			DE Bezeichnung	EN Designation	FR Désignation	ES Designación
	Anzahl quantity quantité número						
	MU-B AGRIA 80	MU-B AGRIA 100	MU-B AGRIA 120				
13	1	MU280025 1	1	Distanzscheibe	spacer	Disque d'écartement	Arandela distanciadora
14	1	MUR20205 1	1	Verschlussdeckel	cap	Couvercie de fermeture	Tapa de cierre
15	1	MU280027 1	1	Passfeder	parallel key	Clavette	Chaveta de ajuste
16		MU0099972		Schraube	bolt	Vis	Tornillo
17	7	MU280028 7	7	Schraube	bolt	Vis	Tornillo
18	1	MU280029 1	1	Schraube	bolt	Vis	Tornillo
19	4	MU280030 4	4	Schraube	bolt	Vis	Tornillo
20	1	MUSAE70W90VS (1l) 1	1	Getriebeöl	gearbox oil	Système d'entraînement pétrole	Cambio aceite
20a	0,8l	0,8l	0,8 l	Füllmenge inclusive Verlängerungswelle	Oil fill quantity inclusive extension shaft	Quantité d'huile inclusive Arbre de rallonge	Cantidad de llenado de aceite inclusivo Eje de prolongación
X	Teile einzeln vom Hersteller nicht lieferbar Parts from the manufacturer cannot be supplied individually Pièces non livrables séparément par le fabricant El fabricante no suministra piezas individuales						

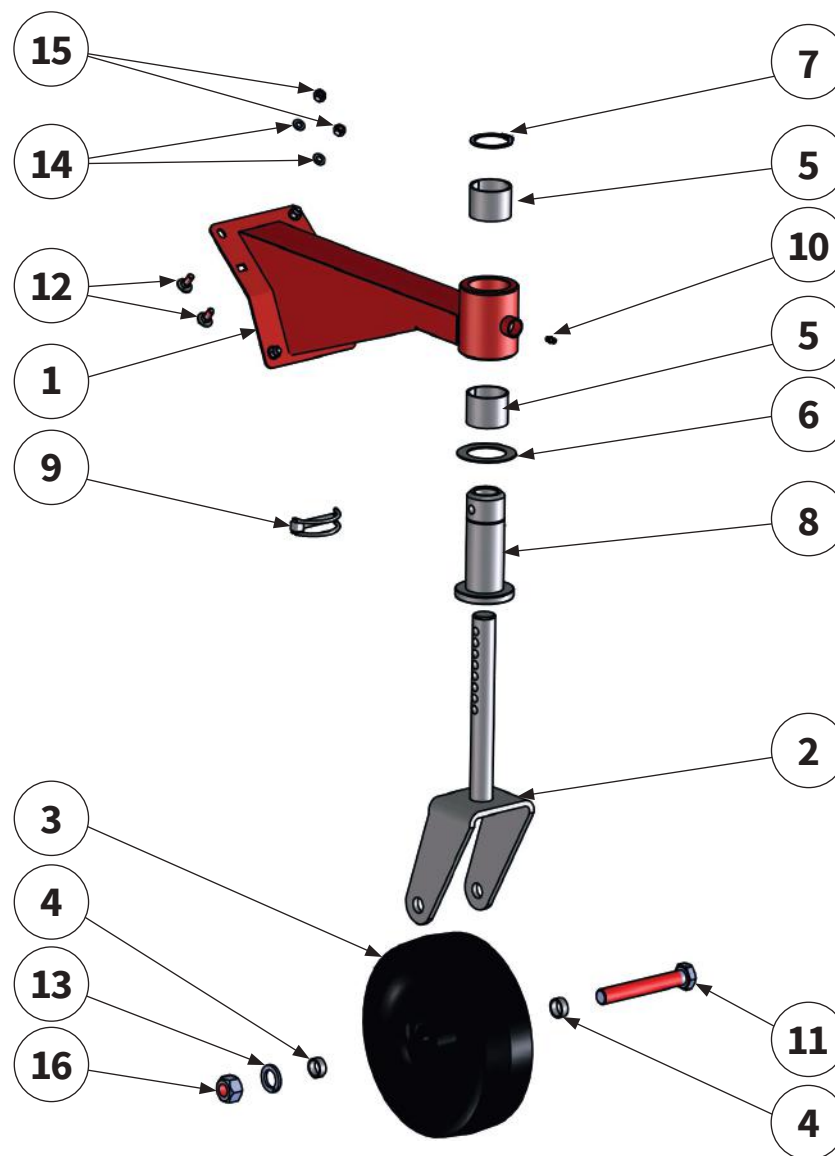

Pos.-Nr. No. Número	Ersatzteilnummer Manufacturer part number Numéro de pièce du fabricant Número de pieza del fabricante			DE Bezeichnung	EN Designation	FR Désignation	ES Designación
	Anzahl quantity quantité número						
	MU-B AGRIA 80	MU-B AGRIA 100	MU-B AGRIA 120				
1	1	00019528 1	1	Stützradträger	support wheel carrier	Support de la roue d' appui	Soporte de la rueda de soporte
2	1	MU0110751 1	1	Radgabel	wheel yoke	Fourche de roue	Horquilla de rueda
3	1	MU0211091-3 1	1	Stützrad	support wheel	Roue d' appui	Rueda de soporte
4	2	MU0211051 2	2	Distanzbuchse	bush	Douille	Casquillo
5	2	MU0211111 2	2	Gleitlagerbuchse	bush	Douille	Casquillo
6	1	MU0211101 1	1	Anlaufscheibe	thrust washer	Rondelle de butée	Arandela de tope
7	1	MU0099990 1	1	Sicherungsring	circlip	Bague de sécurité	Anillo de seguridad
8	1	MU0211071 1	1	Flanschmuffe	bush	Douille	Casquillo
9	1	MU0099946 1	1	Klappsplint	pipe lynch pin	Goupille rabattable	Conector de tapa de tubo
10	1	DIN71412A-H1 M06x1 1	1	Schmiernippel	lubricating nipple	Nipple de graissage	Engrasador
11	1	MU982003 1	1	Laufachse	axle	Essieu	Eje



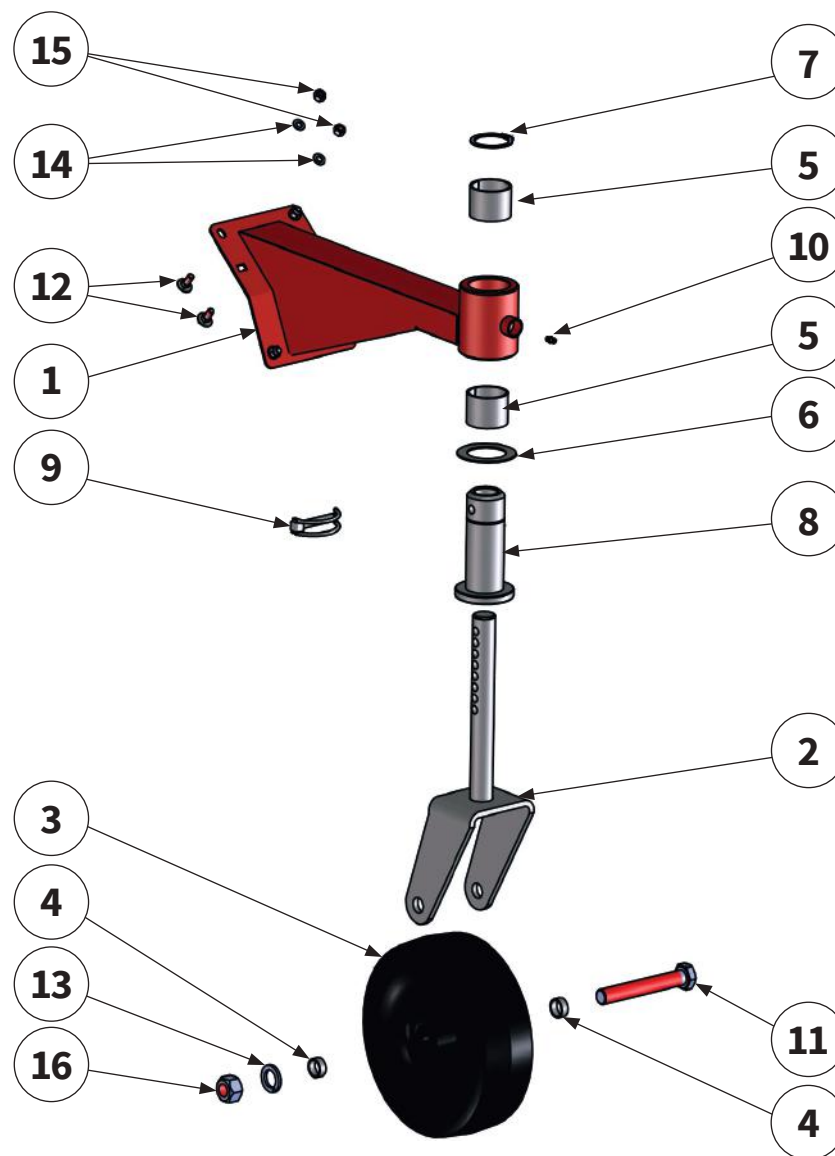

Pos.-Nr. No. Numéro Número	Ersatzteilnummer Manufacturer part number Numéro de pièce du fabricant Número de pieza del fabricante			DE Bezeichnung	EN Designation	FR Désignation	ES Designación
	Anzahl quantity quantité número						
	MU-B AGRIA 80	MU-B AGRIA 100	MU-B AGRIA 120				
12	MU980107			Schraube	bolt	Vis	Tornillo
	8	8	8				
13	MU982007			Federring	spring washer	Rondelle élastique	Anillo elástico
	1	1	1				
14	MU0099999			Scheibe	washer	Disque	Arandela
	8	8	8				
15	MU0099961			Mutter	nut	Écrou	Tuerca
	8	8	8				
16	MU0099959			Mutter	nut	Écrou	Tuerca
	1	1	1				



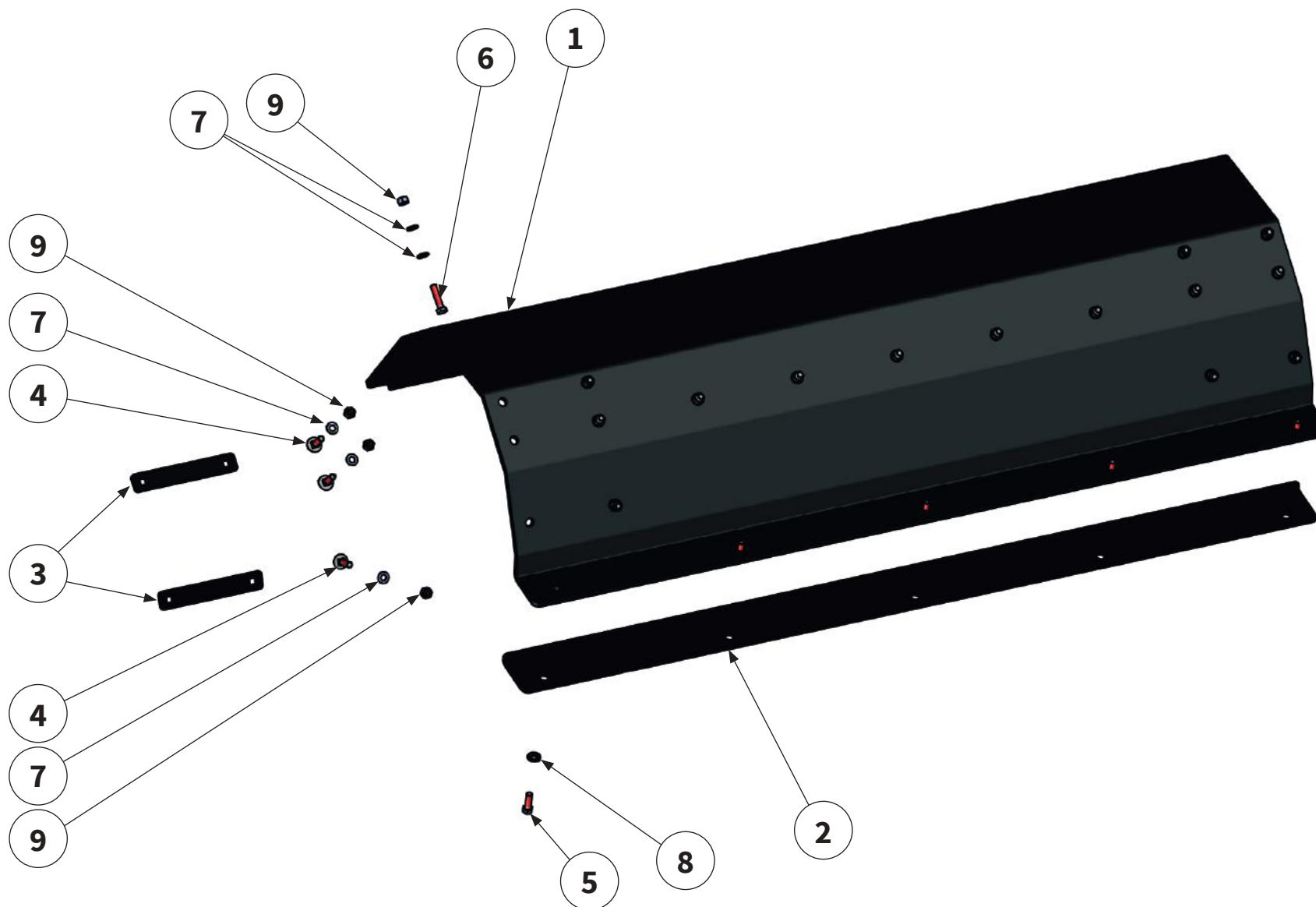

Pos.-Nr. No. Numéro Número	Ersatzteilnummer Manufacturer part number Numéro de pièce du fabricant Número de pieza del fabricante			DE Bezeichnung	EN Designation	FR Désignation	ES Designación
	Anzahl quantity quantité número						
	MU-B AGRIA 80	MU-B AGRIA 100	MU-B AGRIA 120				
1	00019523 1	00019522 1	00019521 1	Verschleißeinlage	wear insert	Blindage	Junta de desgaste
2	00019573 1	00019570 1	00019534 1	Verschleißteil	wear part	Pièce d'usure	De desgaste
3		00019533 4		Blech	sheet metal	Tôle	Chapa
4		MU0099987 15		Schraube	bolt	Vis	Tornillo
5		MU980109 5		Schraube	bolt	Vis	Tornillo
6		MU980108 9		Schraube	bolt	Vis	Tornillo
7		MU0099999 33		Scheibe	washer	Disque	Arandela
8		MUNSKL8 5		Scheibe	washer	Disque	Arandela
9		MU0099961 24		Mutter	nut	Écrou	Tuerca



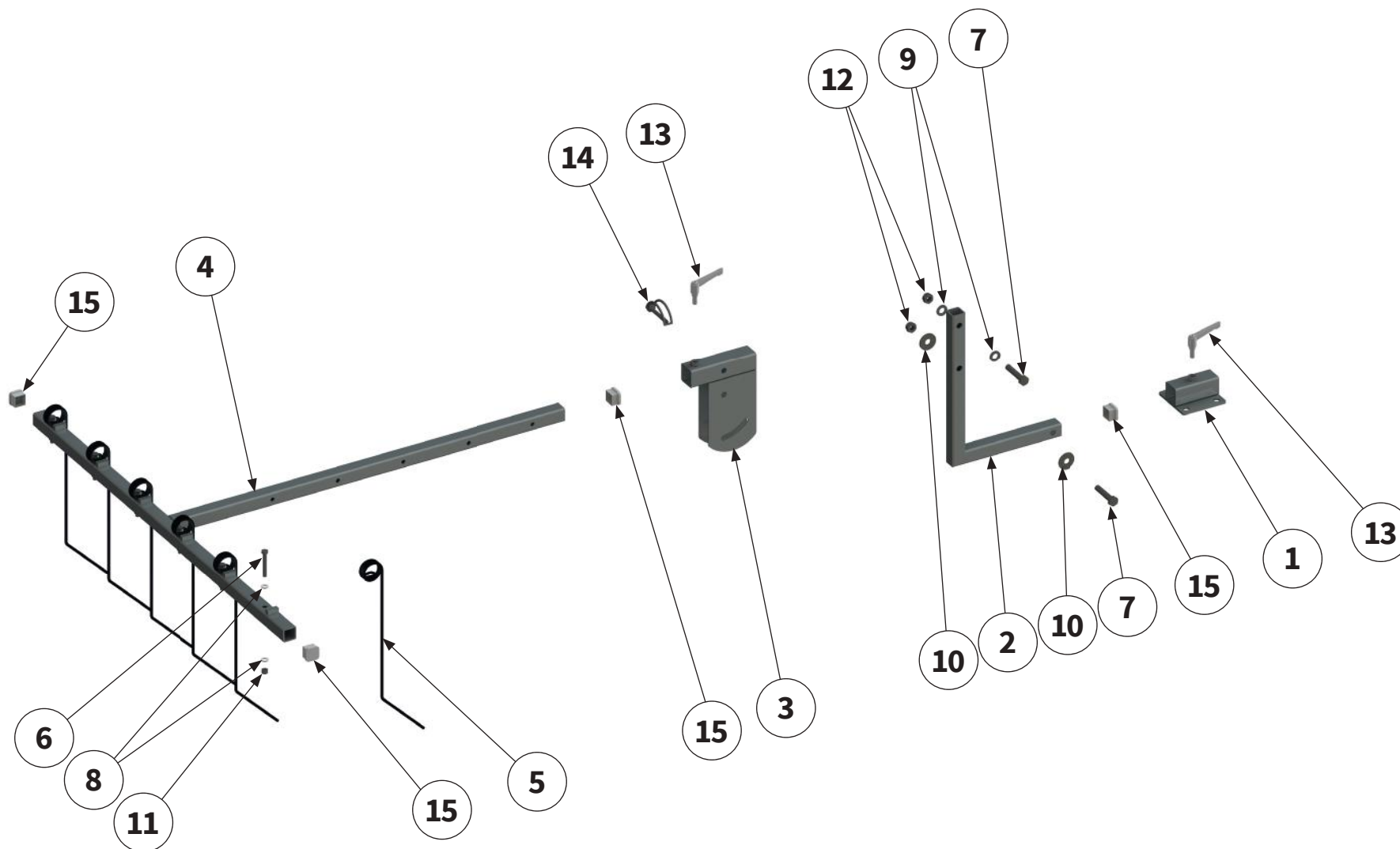

Pos.-Nr. No. Número	Ersatzteilnummer Manufacturer part number Numéro de pièce du fabricant Número de pieza del fabricante			DE Bezeichnung	EN Designation	FR Désignation	ES Designación
	Anzahl quantity quantité número						
	MU-B AGRIA 80	MU-B AGRIA 100	MU-B AGRIA 120				
1	-	00038941 1	-	Halter	holder	Support	Soporte
2	-	00038936 1	-	Rahmen	frame	Cadre	Bastidor
3	-	00038940 1	-	Halter	holder	Support	Soporte
4	-	00038934 1	-	Rahmen	frame	Cadre	Bastidor
5	-	00038938 6	-	Zinken	tines	Dents	Dientes
6	-	MU980118 6	-	Schraube	bolt	Vis	Tornillo
7	-	MU981082 2	-	Schraube	bolt	Vis	Tornillo
8	-	MU0099999 12	-	Scheibe	washer	Disque	Arandela
9	-	MU980302 2	-	Scheibe	washer	Disque	Arandela
10	-	MU980203 2	-	Scheibe	washer	Disque	Arandela
11	-	MU0099961 2	-	Mutter	nut	Écrou	Tuerca
12	-	MU980301 2	-	Mutter	nut	Écrou	Tuerca
13	-	00005605 1	-	Klappstecker	lynch pin	Esse d'essieu	Pasador abatible
14	-	00039006 2	-	Riegel	bolt	Boulon	Cerrojo
15	-	00003433 4	-	Verschlussstopfen	sealing plug	Bouchon de fermeture	Tapón de cierre

Keine Paarung der Y-Messer an dieser Position
No pairing of Y-blades at this position
Aucune paire de couteaux Y à cette position
Sin emparejamiento de cuchillos Y en esta posición

Keine Paarung der Y-Messer an dieser Position
No pairing of Y-blades at this position
Aucune paire de couteaux Y à cette position
Sin emparejamiento de cuchillos Y en esta posición

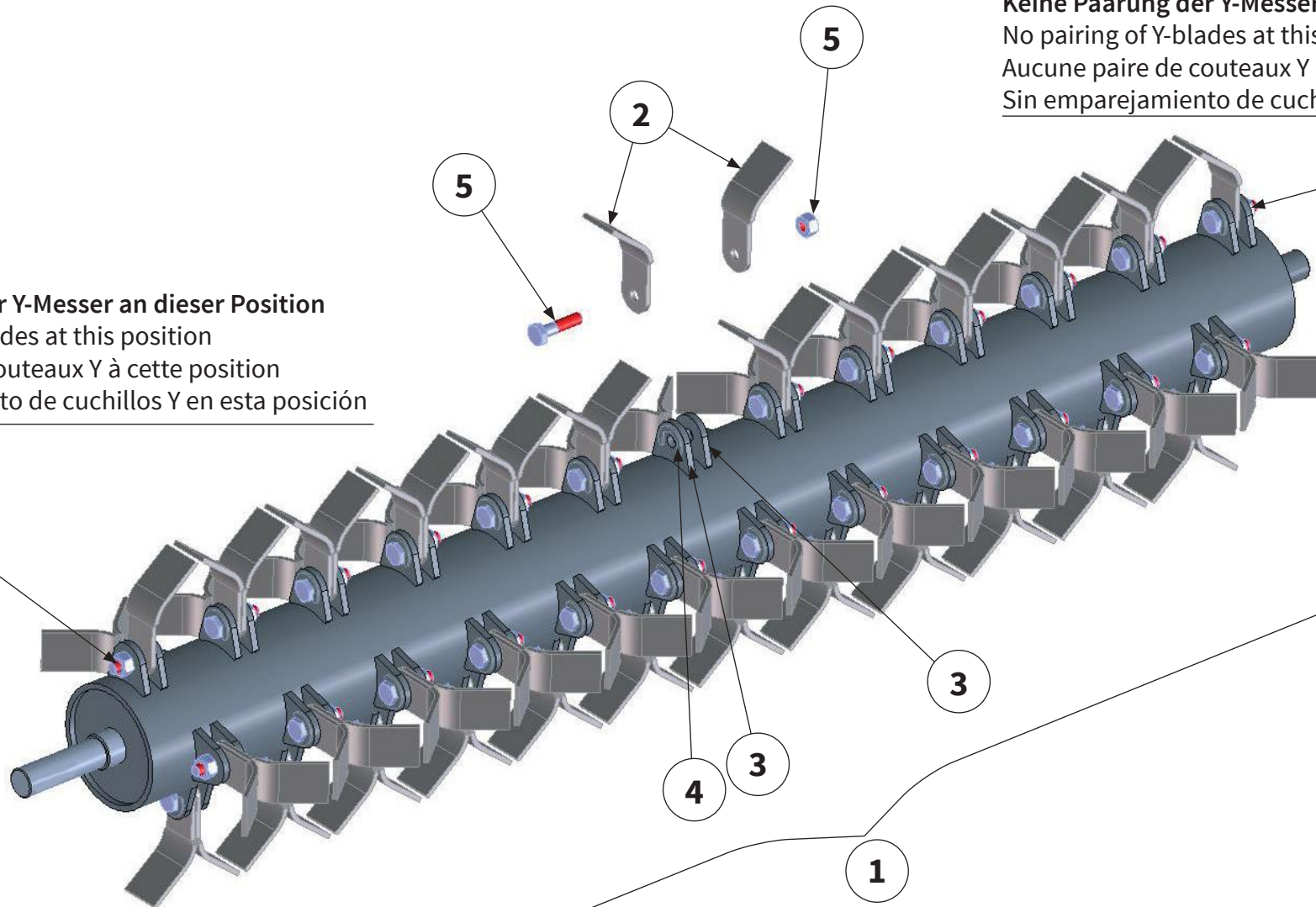

Pos.-Nr. No. Numéro Número	Ersatzteilnummer Manufacturer part number Numéro de pièce du fabricant Número de pieza del fabricante			DE Bezeichnung	EN Designation	FR Désignation	ES Designación
	Anzahl quantity quantité número						
	MU-B AGRIA 80	MU-B AGRIA 100	MU-B AGRIA 120				
1	00019634 1	00003439 1	00003445 1	Rotor inkl. Werkzeug	rotor with tools	Rotor avec outils	Rotor con herram
2	64	00003435 80	96	Y-Messer	Y-blade	Couteau en Y action	Cuchilla en Y de hojas
3	66	00001152 82	98	Werkzeughalter	tool holders	Porte-outils	Portaherramientas
4	33	00001151 41	49	Verdrehsicherung	anti-twist protection	Sécurité anti-torsion	Seguro contra giro
5	33	MU980229 41	49	Schraube mit Mutter	bolt with nut	Vis avec Écrou	Tornillo con Tuerca

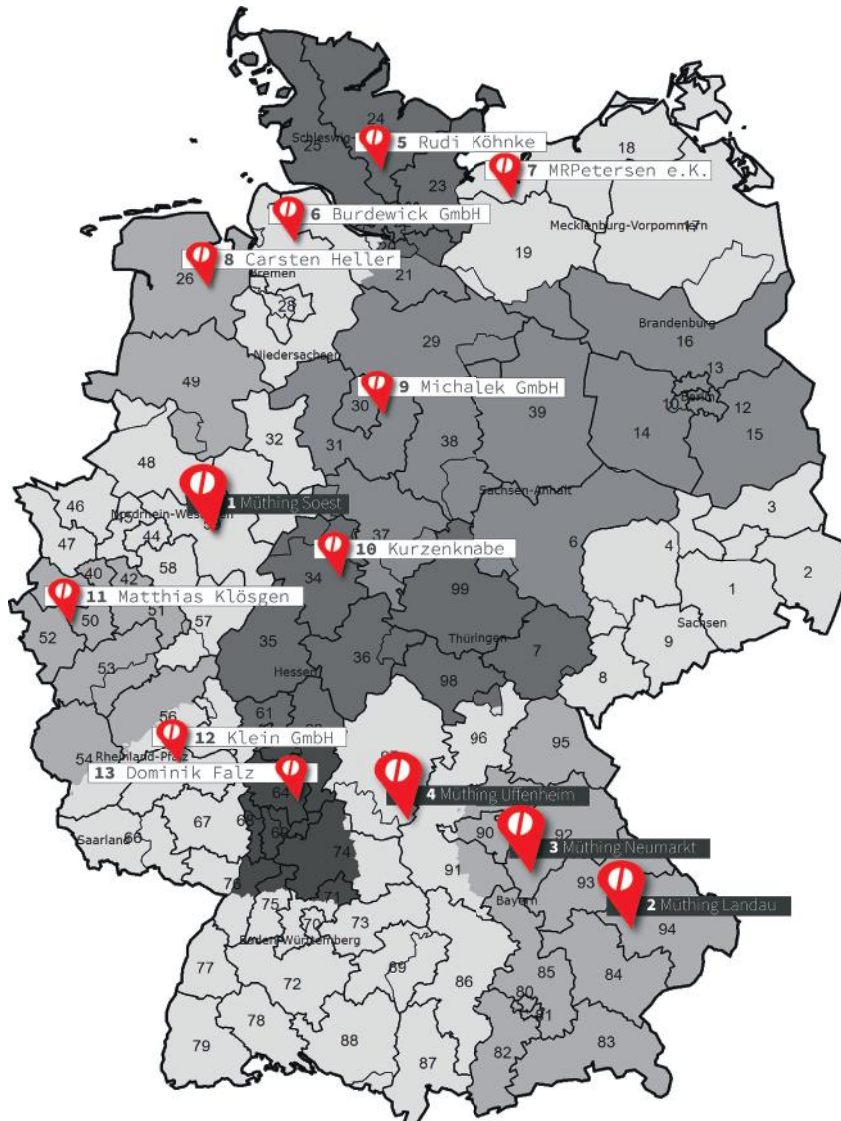

(1) Müthing GmbH & Co. KG Soest

Am Silberg 23
59494 Soest
Tel.: 02921 / 9651 - 0
Fax: 02921 / 73080
E-Mail: et-soest@muething.com

(2) Müthing GmbH & CO. KG Landau

Wiesenweg 6
94405 Landau
Tel.: 09951 / 6908 - 0
Fax: 09951 / 6333
E-Mail: et-landau@muething.com

(3) Müthing GmbH & Co. KG Neumarkt

Hans-Dehn-Str. 7
92318 Neumarkt
Tel.: 09181 / 2976 - 0
Fax: 09181 / 21841
E-Mail: neumarkt@muething.com

(4) Müthing GmbH & Co. KG Uffenheim

Am Brunnlein 2
97215 Uffenheim
Tel.: 09842 / 9866 - 0
Fax: 09842 / 9866 - 67
E-Mail: et-uff@muething.com

(5) Rudi Köhnke

Wohldweg 16
24558 Henstedt-Ulzburg
Tel.: 04193 / 91544
Fax: 04193 / 759576
E-Mail: krkoehnke@aol.com

(6) Burdewick GmbH

Mittelstenaher Str. 33
21769 Lamstedt
Tel.: 04773 / 8941 - 0
Fax: 04773 / 8941 - 41
E-Mail: info@burdewick.de

(7) MRPetersen e.K. Werksvertretung

Christiansburger Weg 20
24969 Lindewitt / OT Sillerup
Tel.: 04604 / 9866 - 36
Fax: 04604 / 9866 - 37
E-Mail: rp@mrpetersen.de

(8) Müthing GmbH & Co. KG Soest - Carsten Heller Werksbeauftragter

Tel.: 0160 / 96919245
Fax: 04461 / 759302
E-Mail: c.heller@muething.com

(9) Michalek GmbH

Industriestraße 14
31275 Lehrte
Tel.: 05132 / 2006 - 0
Fax: 05132 / 2006 - 30
E-Mail: info@michalek-ww.de

(10) Kurzenknabe

Obervellmarer Weg 36
34314 Espenau
Tel.: 05673 / 4012
Fax: 05673 / 2495
E-Mail: info@kurzenknabe-gmbh.de

(11) Matthias Klösger

Drovestrasse 104
52372 Kreuzau
Tel.: 02422 / 9019 - 25
Fax: 02422 / 9019 - 26
E-Mail: matthias.kloesger@t-online.de

(12) Klein GmbH

Hauptstraße 2
55627 Weiler / Nahe
Tel.: 06754 / 404
Fax: 06754 / 643
E-Mail: klein-ww-weiler@t-online.de

(13) Dominik Falz

Carl-Benz- Str. 4
64711 Erbach / Odw.
Tel.: 06062 / 1867
Fax: 06062 / 61851
E-Mail: d.falz@muething-mulcher.de

Bei weiteren Fragen zu Technik und Einsatz Ihres Gerätes stehen Ihnen unsere Mitarbeiter oder unsere Vertriebspartner gerne zur Verfügung.

Our employees or sales partners are happy to help should you have any further questions on the technical aspects and use of your implement.

Nos collaborateurs ou nos partenaires commerciaux sont à votre entière disposition pour toutes questions complémentaires relatives aux caractéristiques techniques ou à l'utilisation de votre engin.

Tanto nuestros empleados como los socios comerciales de la marca estamos a su disposición para atender cualquier consulta técnica o sobre piezas que pueda tener respecto a su equipo.

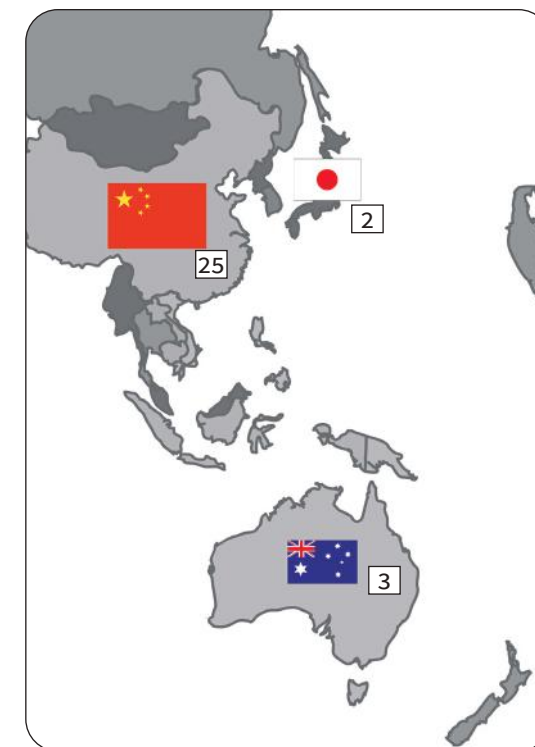

**(1) Prairie Agri Sales Ltd.**

W. Heidebrecht
P.O Box 216
Road 6W , 26028
Lowe Farm, MB R0G 1E0
Tel.: 001-204-746-6994
Fax: 001-204-515-4064
E-Mail: wheidebrecht@prairiegrisaes.ca

**(6) IP Innovations et Paysage**

ZI de Saint Nizier
F - 42190 Charlieu
Tel.: 0033 / 477 605454
Fax: 0033 / 477 606846
E-Mail: info@innovex-gmbh.de

**(11) Oy J-Trading Ab**

Kuriiritie 15
01510 Vantaa
Tel.: 00358 / 207458600
Fax: 00358 / 207458651
E-Mail: info@j-trading.fi

**(16) EZ Agrar e. Gen**

Salzburger Straße 38
4020 Linz
Tel.: 0043 / 732 347266
Fax: 0043 / 732 347260
E-Mail: office@ezagr.ar.at

**(21) Mühling GmbH & Co. KG Soest**

Am Silberg 23
59494 Soest
Tel.: 02921 / 9651 -0
Fax: 02921 / 73080
E-Mail: et-soest@muething.com

**(2) Agri Direct Co. Ltd.**

Higashimemuro, Memuro-cho,
Kasai-gun
18-7 Kita 1-sen
Hokkaido 082-0004
Tel.: 0081 / 155612777
Fax: 0081 / 155612755
E-Mail: info@agridirect.jp

**(7) GTJ**

Peter Janssen
Way Broek 5
6041PJ Roermond
Tel.: 0031 / 615370411
E-Mail: p.janssen@gtjtrading.nl

**(12) Brøns Group**

Hovedvejen 20
6780 Skærbæk
Tel.: 0045 / 74753112
E-Mail: brons@bronsgroup.com

**(17) Güttler Mezőgazdasági**

Gépgyárto és Szolgá Kft.
Külterület 022/ 35
6800 Hódmezővásárhely
Tel.: 0036 / 62 533690
Fax: 0036 / 62 533691
E-Mail: orsolay.torok@guttler.hu

**(22) Mühling GmbH & Co. KG Uffenheim**

Am Brunnlein 2
97215 Uffenheim
Tel.: 09842 / 9866 - 0
Fax: 09842 / 9866 - 67
E-Mail: et-uff@muething.com

**(3) Southern Cross Mowers PTY Ltd.**

Marcus Cornish
1/29 Mustang Drive, PO Box 454
Rutherford NSW Australia 2320
Tel.: 0061 / 240440313
Fax: 0061 / 249321088
E-Mail: mcornish@sxm.com.au

**(8) Van Dyke Marcel Belgium**

Provinciebaan 71 - 2235 Houtvenne
Tel.: 0032 / 16699156
E-Mail: info@vandyck.be
GÖWEIL BNL PGmbH - Mirfeld
Zur Schmiede 23 - 4770 Amel
E-Mail: office@goeweil.be

**(13) Konekesko Eesti AS**

Pildiküla Rae vald
Porguvälja tee 3a
75308 Harjumaa MK
Tel.: 00372 / 6059100
Fax: 00372 / 6059101
E-Mail: kristjan.nelis@kesko.ee

**(18) Topagri S.r.o.**

Kostalkova 1527
26601 Beroun
Tel.: 00420 / 311 636766
Fax: 00420 / 311621822
E-Mail: topagri@topagri.cz

**(23) EZ Landmaschinen AG**

Bützbergstrasse 70
4912 Aarwangen
Tel.: 0041 / 62 9226801
Fax: 0041 / 62 9230369
E-Mail: info@ezlandmaschinen.ch

**(4) Simon Richard Ltd.**

Crown Tailrig
Simon Richardt
Bonchester Bridge
Hawick TD9 8RA
Tel.: 0044 / 1450860774
Fax: 0044 / 1450860772
E-Mail: mail@simon-richard.co.uk

**(9) Felten Freres et Fils Sarl**

Zone Artisanale
9775 Weicherdange
Tel.: 00352 921612
Fax: 00352 920530
E-Mail: info@felten.lu

**(14) SIA BALTIC AGRO-RIG**

Tiraines street 15
1058 Riga
Tel.: 00371 / 26303830
Fax: 00371 / 63001761
E-Mail: edgars.gabrums@kesko.lv

**(19) Ematech s.r.o**

Piestanska 3/3
95605 Radosina
Tel.: 00421 / 385398119
Fax: 00421 / 385398216
E-Mail: ematech@ematech.sk

**(24) G.I.Antonakis A.E.**

3 xlm Thiva-Mouriki
32200 Thiva
Tel.: 0030 / 2262 025915
Fax: 0030 / 2262 025914
E-Mail: gianton@otenet.gr

**(5) Delgado Delgado e Hijos, S.A.**

C / Sevilla , 23
34004 Palencia
Tel.: 0034 / 979728450
Fax: 0034 / 979710390
E-Mail: recambios@deltacinco.es

**(10) ForSentralen AS**

Einar M. Bardal/ Carl M. Bardal
Bardalsvegen 100
7724 Steinkjer
Tel.: 0047 / 7414-7600
Fax: 0047 / 7414-9399
E-Mail: forsentralen@online.no

**(15) UAB Konekesko**

Vilnius raj.
Moletu g. 13
14262 Didžioji Riese
Tel.: 00370 / 46421752
Fax: 00370 / 46421753
E-Mail: vilnius.sventkauskas@kesko.lt

**(20) NHR Agropartners SRL**

Judet Ilfov
Calea Bucurestilor 247
075100 Otopeni
Tel.: 0040 / 21 3007906
Fax: 0040 / 213521660
E-Mail: office@vait.ro

**(25) Ten Square International Inc. Nanjing**

Rm.402 Bldg.2, Zhongqing Plaza NO.96
Caochangmen St. Nanjing, Jiangsu
210013 China
Tel.: 0086 / 25 86210358
Fax: 0086 / 25 86212081
E-Mail: usoffice@tensquareintl.com

20 horizontal dotted lines for writing.





Müthing GmbH & Co. KG Soest
Am Silberberg 23
59494 Soest

Tel +49 (0) 2921 96510
Fax +49 (0) 2921 73080
soest@muething.com

Müthing GmbH & Co. KG Uffenheim
Am Brünlein 2
97215 Uffenheim

Tel +49 (0) 9842 98660
Fax +49 (0) 9842 98667
uffenheim@muething.com

WWW.MUETHING.COM